

THIS DOCUMENT AND THE INFORMATION CONTAINED HEREIN IS CONFIDENTIAL AND IS NOT TO BE REPRODUCED, USED OR DISCLOSED IN WHOLE OR IN PART WITHOUT THE EXPRESS WRITTEN PERMISSION OF TALLYSMAN WIRELESS INC.

NOTES:

1. UNLESS OTHERWISE SPECIFIED, ALL DIMENSIONS ARE IN INCHES.
TOLERANCES:
2 DECIMAL PLACES ± 0.02
3 DECIMAL PLACES ± 0.005
ANGLES $\pm 1^\circ$
2. TO CONVERT INCHES TO MILLIMETRES
USE 1 INCH = 25.40 MILLIMETRES.
3. MATERIAL: ALUMINIUM 5052-H32 SHEET
.064 THICK
4. FINISH: CLEAR ANODIZE
5. UNLESS OTHERWISE SPECIFIED, ALL INSIDE BEND RADIUS TO BE 0.06 MAXIMUM.
6. UNLESS OTHERWISE SPECIFIED, ALL ANGLES TO BE 90° .
7. REMOVE ALL BURRS AND SHARP EDGES.

REVISIONS				
ZONE	REV	DESCRIPTION	DATE (DA-MO-YR)	APPROVED
	1	INITIAL RELEASE	27 JAN 11	M.G.

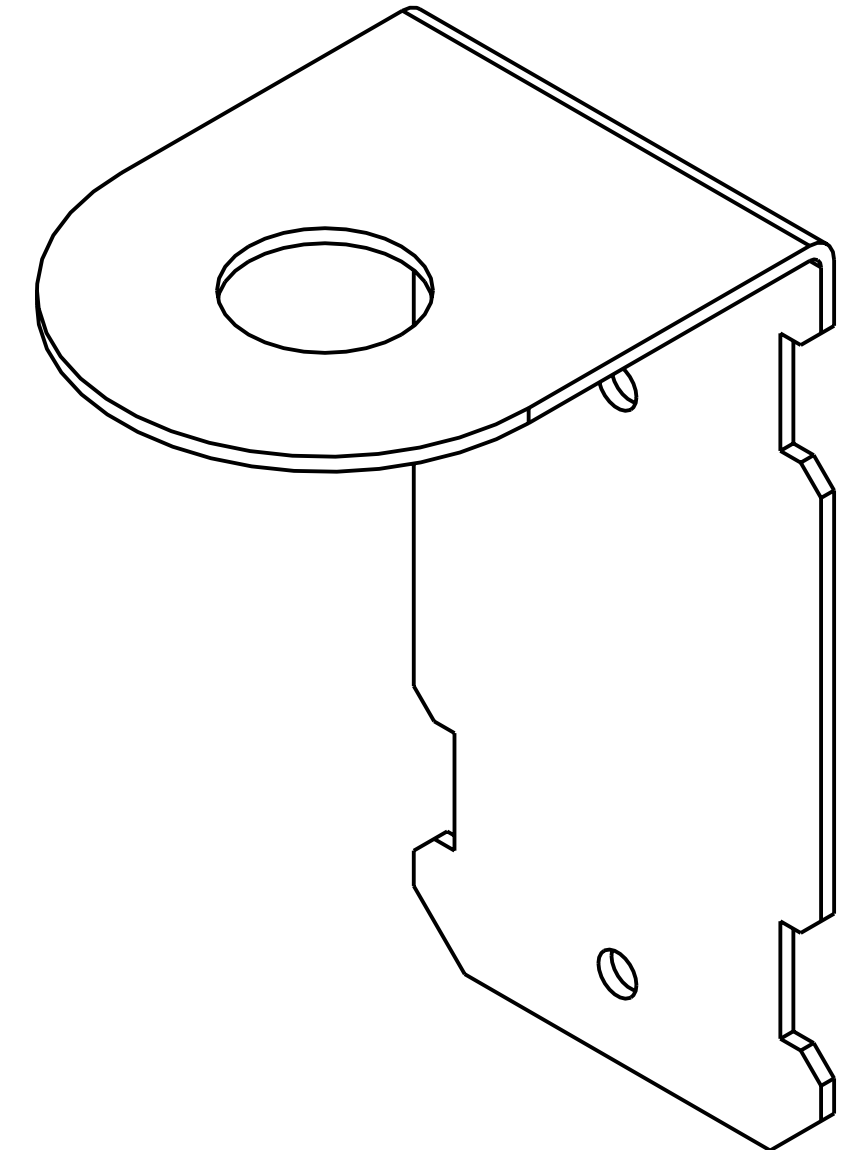
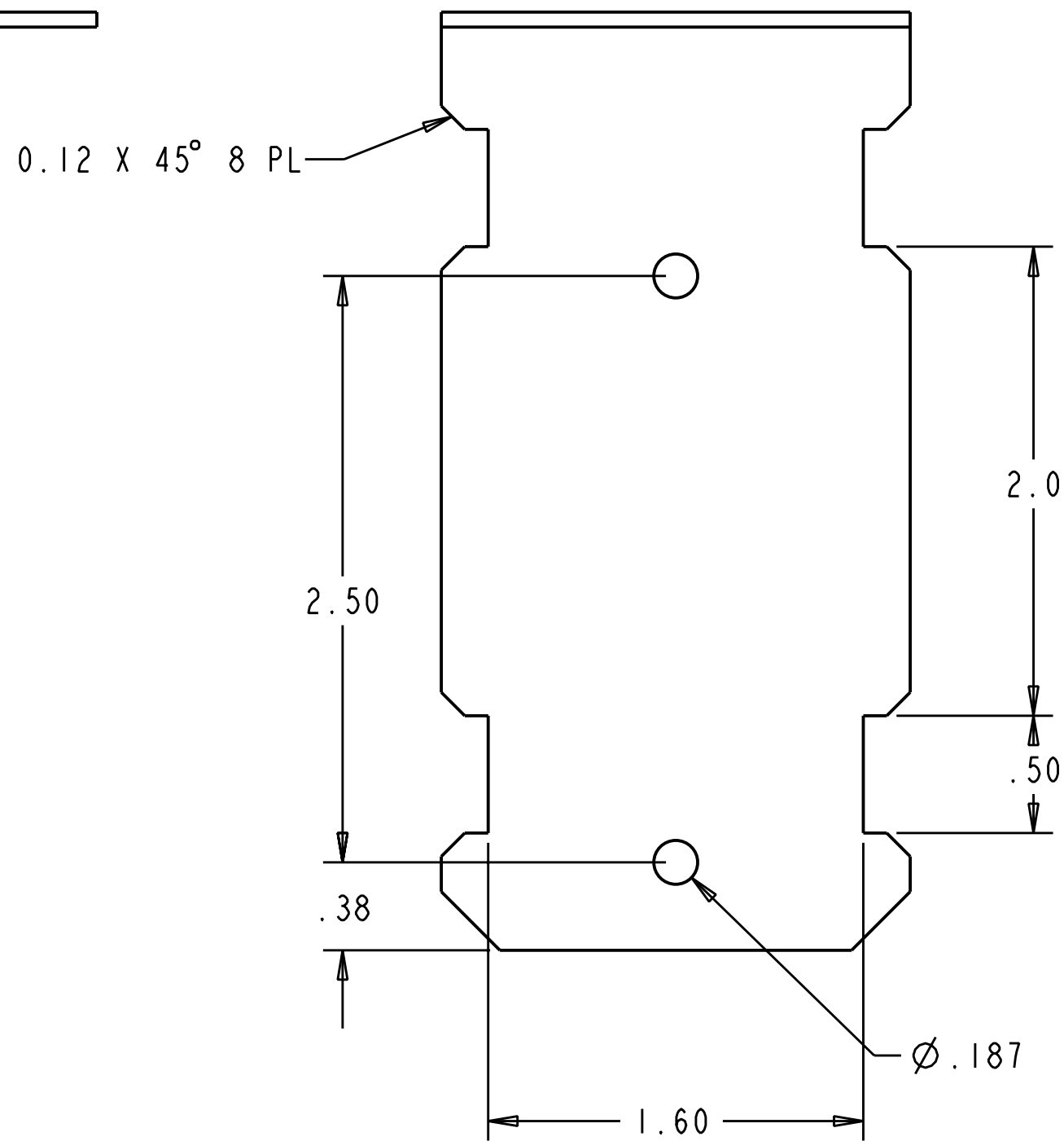
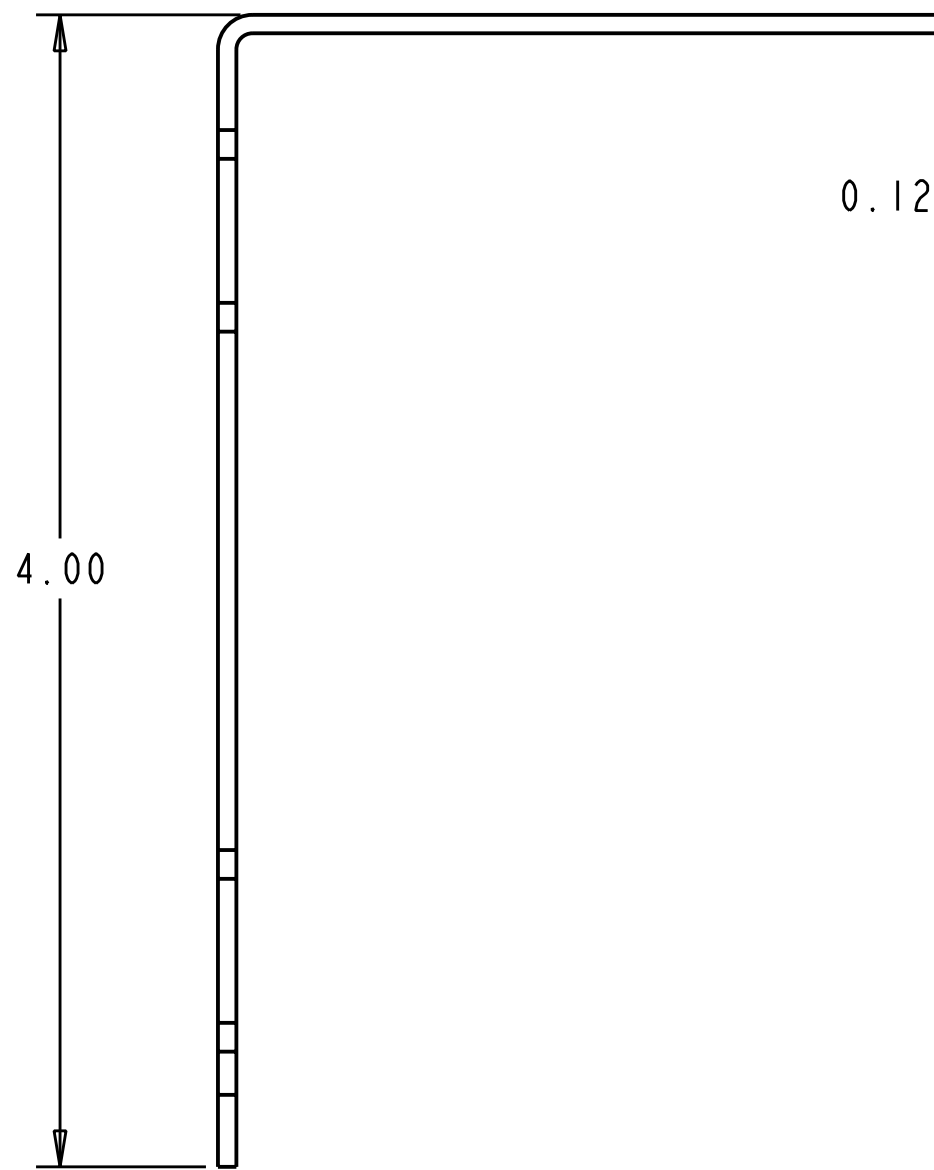
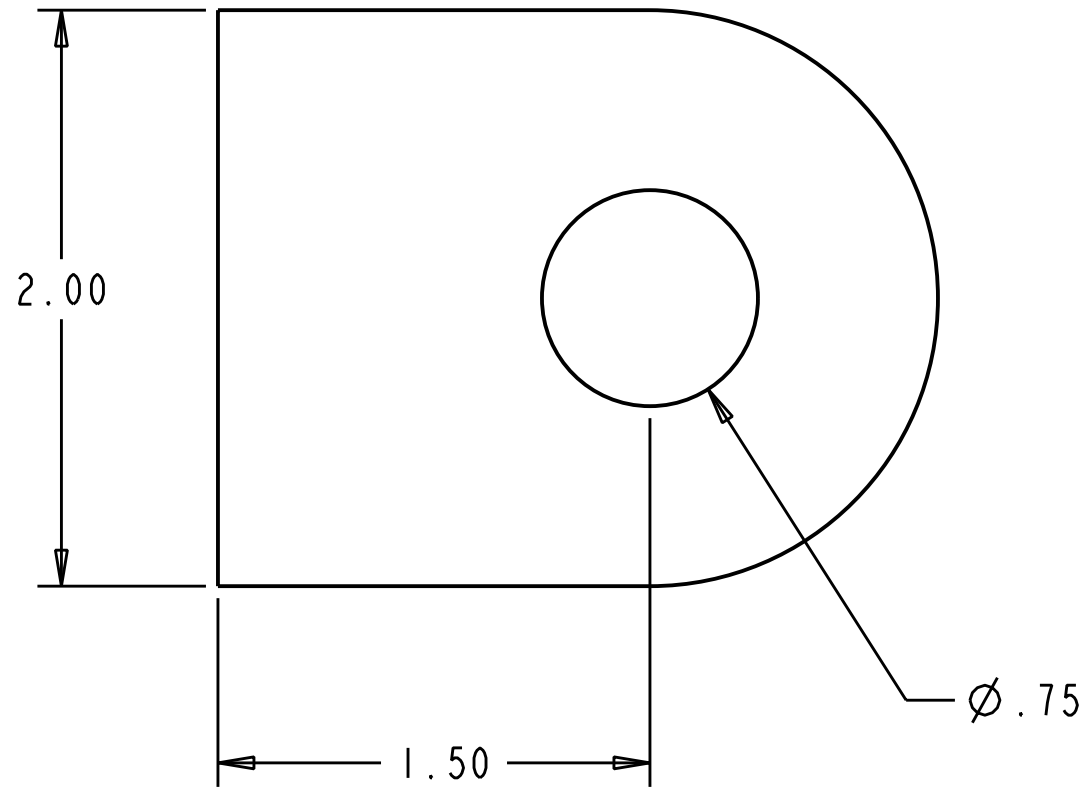

THIRD ANGLE PROJECTION		Tallysman Wireless Inc.	
PMIC		POLE MOUNT BRACKET	
GEN. BY B DOLAN	DATE (Y-M-D) 27 JAN 11		
REVIEWED BY M GRINSTEAD			
PROJECT	SIZE C	CAGE CODE	DRAWING NUMBER 23-0040-0
NEXT ASSEMBLY	SCALE	UNIT WT	SHEET 1 OF 1