

ATLANTIC VERSION TERMINATOR INTERFACE ADAPTER	PART NUMBER	REVISION	DESCRIPTION	FEED TYPE	APPLICATOR STYLE CONVERSION CHART						
					CONVERT TO	PART NUMBERS REQUIRED					
	2151760-2	A	FINE CRIMP HEIGHT ADJUST	PNEUMATIC	-	-	1338683-8	5-18022-5	-	-	-
	2151760-5	A	FINE CRIMP HEIGHT ADJUST	SERVO LATCH PLATE	SERVO LATCH PLATE	2119951-1	-	8-2151760-5	1901094-3	-	2168400-6 (QUANTITY 2)
	2151760-6	A	NON-CRIMP HEIGHT ADJUST	SERVO LATCH PLATE	PNEUMATIC FEED	2119950-1	1338683-8	5-18022-5	2119641-1	2119799-1	2063440-2
	2151760-7	A	FINE CRIMP HEIGHT ADJUST	NONE	-	-	-	-	-	-	-
	7-2151760-7	A	CRIMP TOOLING KIT	-	-	-	-	-	-	-	-

APPLICATOR DATA		
CRIMP WIRE	SIZE	TYPE
6.35 mm [.250]	F	
INSUL	8.26 mm [.325]	F

APPLICATOR INSTRUCTIONS 408-10389

TERMINAL DATA: G&H Lear TERMINAL TE CRIMP SPECIFICATION			
TERMINAL NAME: TERMINAL			
WIRE STRIP LENGTH		INSULATION DIAMETER RANGE	
5.50-7.00 mm [.217-.276 IN]		Ø0.00-6.22 mm [.000-.245 IN]	
TERMINAL APPLICATION SPECIFICATION	NONE		
TERMINALS APPLIED			
TE TERMINAL	G&H Lear TERMINAL	TE TERMINAL	G&H Lear TERMINAL
2113297-1	26741.122.179		

WIRE SIZE	CRIMP HEIGHT mm [INCH]	CRIMP HEIGHT REFERENCE SETTING
10.00mm2	4.80 +/- 0.05 [.189 +/- .002]	1.2
6.00mm2	3.76 +/- 0.05 [.148 +/- .002]	13.5

- 1 RECOMMENDED SPARE PARTS
- 2 GREASE BEARING SURFACES LIGHTLY
- 3. LUBRICATE DAILY PER THE APPLICATOR INSTRUCTION SHEET SUPPLIED WITH THE APPLICATOR.
- 4 APPLICATOR SPECIFIC DATA TO BE ENTERED INTO BLANK MEMORY CHIP AT ASSEMBLY. SEE BELOW FOR PART NUMBER:
 PNEUMATIC FEED WITH "SMART APPLICATOR" CONVERSION: 8-2151760-4
 SERVO FEED WITH "FINE CRIMP HEIGHT ADJUST": 8-2151760-5
 SERVO FEED WITH "NON-CRIMP HEIGHT ADJUST": 8-2151760-6
- 5. ADJUSTMENT OF THE STRIPPER MAY BE REQUIRED WHEN MOVING THE APPLICATOR BETWEEN BENCH AND LEADMAKER APPLICATIONS.
- 6 APPLY PART NUMBER 1-23419-5 LOCTITE TO THREADS OF ITEM 50,62 & 242. FOR -6 ONLY APPLY PART NUMBER 1-23419-5 LOCTITE TO THREADS OF ITEMS 37,50 & 242.
- 7 GREASE THREADS, GROOVE AND O-RING ON ITEMS 35 & 252.
- 8 MAGNET, ITEM 166 MUST BE ORIENTED CORRECTLY IN ORDER TO PROPERLY ACTUATE THE COUNTER.
- 9 CRIMP HEIGHT REFERENCE SETTING WAS THE SETTING USED WHEN THE APPLICATOR WAS QUALIFIED AT THE FACTORY. ADJUSTMENT MAY BE NECESSARY WHEN RUNNING APPLICATOR IN THE FIELD.
- 10 TERMINAL PITCH NOT COMPATIBLE WITH MECHANICAL FEED.
- 11 TO CONVERT THE APPLICATOR TO A NON-CARRIER CUTTING STYLE, REMOVE ITEM 13 AND ATTACH TO THE LOCATION ON THE BACK SIDE OF THE HOUSING. REFER TO INSTRUCTION SHEET FOR ADDITIONAL INFORMATION.
- 12 WHEN ASSEMBLING -6 NON-CRIMP HEIGHT ADJUST APPLICATOR USE SHIM PACK 2119957-2 TO ALIGN APPLICATOR'S MAXIMUM WIRE CRIMP HEIGHT AT NORMAL TERMINATOR SHUT HEIGHT
- 13 GRIND AT ASSEMBLY.

***WARNING**
 ON INSTALLATION, SET WIRE DISC, ITEM 40 TO LARGEST WIRE SIZE SETTING. USE OF SETTINGS BELOW MINIMUM REQUIRED CRIMP HEIGHT SETTING WILL CAUSE DAMAGE TO CRIMP TOOLING.

-77	-7	-6	-5	-2	PART NO	DESCRIPTION	ITEM NO
-	1	1	1	1	2119091-2	SHIM, LAMINATE	270
-	1	1	1	1	1633782-3	FENCE	267
-	-	1	-	-	2119957-2	APPLICATOR SHIM PACK	260
-	1	1	1	1	455888-5	SPACER, CRIMPER	259
-	1	-	1	1	8-21084-0	O-RING, .676 ID, .070 DIA. MAT.	252
-	-	-	-	1	2119640-1	PUSH ROD, AIR FEED	250
-	-	-	-	1	2079988-1	BUSHING, LCH5-12, MISUMI	249
-	-	-	-	1	2119641-1	FEED CAM, AIR FEED	248
-	1	-	1	1	2119798-1	DETENT PIN	247
-	1	-	1	1	1-22279-3	SPRING, COMPRESSION	246
-	-	1	-	-	2161314-1	RAM, STEPPED, AMP STYLE, SIDE FEED, NON-ADJUST	245
-	1	1	1	1	2119082-9	CAM, SNAIL, INSULATION ADJUSTMENT	244
-	1	1	1	1	2079764-1	WASHER, WAVE SPRING, CREST-TO-CREST	243

ATLANTIC VERSION
 Shown on sheets 1 of 4 & 2 of 4
 (Pacific version shown on sheets 3 of 4 & 4 of 4)

SET UP GAUGE	LOC	DIST	REVISIONS			
2119599-1	A	66	REV	DATE	BY	APPV
			1	15OCT2012	GH	TE
			2	18OCT2012	GH	TE
			A	25JAN2013	GH	TE

REV	DATE	BY	APPV	DESCRIPTION	ITEM NO		
-	1	1	1	2119083-1	RETAINER, INSULATION DIAL	242	
-	1	1	1	7-18023-7	SCR, SKT HD CAP M3 X 4.0	241	
-	-	2	2	2168400-6	SHCS, LOW HEAD, RoHS, M5 X 16	240	
-	-	-	1	2063440-2	AIR FEED MODULE	238	
-	-	1	1	2119740-2	TAG, IDENTIFICATION	213	
-	-	1	1	1901094-3	SPACER, FEEDER	198	
-	1	1	1	993111-1	PIN, SLOTTED SPRING 3.0 X 20.0	177	
-	1	1	1	8-22280-7	SPRING, COMPRESSION	176	
-	1	1	1	1752353-2	GUIDE PIN, HOLDDOWN	175	
-	1	1	1	1901680-2	GUIDE PIN, HOLDDOWN	174	
-	-	-	2	21045-3	RING, RETAIN, EXTERN, 3/16 CRESCENT	172	
-	1	1	1	994969-1	MAGNET, RARE EARTH HIGH ENERGY	166	
-	REF	REF	REF	REF	994970-2	COUNTER, MAGNETIC	164
-	-	-	-	1	240638-1	SPRING, FEED FINGER	163
-	-	-	-	1	3-23627-7	PIN, RETAIN, GRVD, 3/16 X .854	137
-	-	-	-	1	2119799-1	HOLDER, FEED FINGER, AF	136
-	-	REF	REF	-	SEE NOTE 4	MEMORY CHIP, PROGRAMMED	135
-	-	1	1	-	1633743-1	SERVO FEED LATCH ASM	133
-	1	1	1	1	1-22281-8	SPRING, COMPRESSION	121
-	1	1	1	1	2-690438-2	FRONT STRIP GUIDE	96
-	4	4	4	4	2168083-1	SCR, SKT HD CAP, RoHS, M3 X 8.0	95
-	1	1	1	1	2168083-6	SCR, SKT HD CAP, RoHS, M5 X 6.5	93
-	1	1	1	1	318563-1	GUARD, FRONT CHIP	89
-	1	1	1	1	2-455888-7	SPACER, CRIMPER	82
-	1	1	1	1	2119956-1	DOCUMENTATION PACKAGE	71
-	1	-	-	1	2119740-1	TAG, IDENTIFICATION	67
-	2	2	2	2	2168078-1	SCREW, DRIVE, RH, RoHS	66
-	1	-	1	1	2119793-1	LIMITER, ADJUSTMENT BOLT	63
-	3	-	3	3	992763-5	SCR, SET, SOC, CONE POINT, M3 X 4.0	62
-	2	2	2	2	2-18032-5	SCR, SET, FLT POINT M5 X 20.0	61
-	1	1	1	1	2079383-4	SCR, BHSC, RoHS (M4 X 8)	60
-	-	-	-	1	5-18022-5	SCR, HEX HD CAP, M4 X 6.0	59
-	-	-	-	1	1-1338683-1	FEED PAWL	56
-	4	4	4	4	2168400-1	SHCS, LOW HEAD, RoHS, M4 X 12	54
-	1	1	1	1	1-5018030-0	NUT, HEX, REG, RoHS, M3.5	52
-	1	1	1	1	1901681-2	HOLDDOWN, TERMINAL	51
-	1	1	1	1	2-1752354-1	STANDOFF, HOLD-DOWN	50
-	-	-	-	1	18023-9	SCR, SKT HD CAP M4 X 6.0	49
-	1	1	1	1	2119656-9	APPLICATOR BASIC ASSEMBLY, SF	46
-	1	-	1	1	2161311-1	RAM, STEPPED, AMP STYLE, SIDE FEED	44
-	1	1	1	1	1-2079383-5	SCR, BHSC, RoHS (M8 X 40)	41
-	1	-	1	1	2119645-1	DISC, NUMBERED FA WIRE ADJUSTMENT	40
-	1	-	1	1	2119957-1	APPLICATOR SHIM PACK	39
-	1	1	1	1	2119644-8	RAM WASHER, PRECISION	38
-	1	1	1	1	2119085-1	FA HEAD, ATLANTIC STYLE	37
-	1	-	1	1	2119092-1	BOLT, ADJUSTMENT	35
-	1	1	1	1	3-1752356-3	SUPPORT, TERMINAL	34
-	2	2	2	2	1-2079383-3	SCR, BHSC, RoHS (M4 X 25)	33
-	1	1	1	1	2161328-1	HEX HEAD, FLANGED, M5 x 8mm LONG	32
-	1	1	1	1	2-1320908-5	SPACER, STRIP GUIDE	30
-	1	1	1	1	1901086-9	PLATE, STRIP GUIDE	29
-	1	1	1	1	1-455888-0	SPACER, CRIMPER	28
-	2	2	2	2	22281-9	SPRING, COMPRESSION	27
-	1	1	1	1	356835-1	LEVER, DRAG RELEASE	26
-	1	1	1	1	240792-1	DRAG, TERMINAL	25
-	1	1	1	1	1320928-6	STRIP GUIDE	24
-	1	1	1	1	980371-4	SCR, SKT HD SHLDR 5.0 DIA X 6.0	23
-	1	1	1	1	2168083-2	SCR, SKT HD CAP, RoHS, M4 X 8.0	21
-	1	1	1	1	1-18028-2	WASHER, FLAT, REG M4	20
-	1	1	1	1	2119533-2	STRIPPER, SIDE FEED	19
-	1	1	1	1	2119806-1	INSERT, SHEAR	13
-	1	1	1	1	3-22280-3	SPRING, COMPRESSION	12
-	1	1	1	1	1-356885-3	STOP, SHEAR	11
-	1	1	1	1	2119805-1	SHEAR HOLDER, FRONT	10
-	1	1	1	1	318707-8	FLOATING SHEAR, FRONT	9
-	1	1	1	1	1633929-1	ANVIL, COMBINATION	8
-	-	-	-	-	-	-	7
-	-	-	-	-	-	-	6
-	1	1	1	1	1-2119757-3	DEPRESSOR, SHEAR	5
-	1	1	1	1	238011-3	BLOCK, CRIMPER SPACER	4
-	1	1	1	1	5-1633961-7	CRIMPER, INSULATION F PREMIUM	3
-	1	1	1	1	2-455888-2	SPACER, CRIMPER	2
-	1	1	1	1	456432-8	CRIMPER, WIRE	1

DIMENSIONS:	TOLERANCES UNLESS OTHERWISE SPECIFIED:	OWN	DATE	NAME	RESTRICTED TO
mm	0 PLC ±.1 1 PLC ±0.1 2 PLC ±0.02 3 PLC ±0.005 4 PLC ±0.0005 ANGLES ±.1	OFFNER	12OCT2012	TE Connectivity Harrisburg, PA 17105-3608	
		ELBIN	15OCT2012		
		ELBIN	15OCT2012		
				Ocean Side Feed Applicator	
				SIZE CAGE CODE DRAWING NO	
				A1 00779 C=2151760	
				Customer Accessible Production Drawing	
				SCALE 1:2 SHEET 1 OF 4 REV A	

LOC		DIST		REVISIONS			
A	66	P	LTM	DESCRIPTION	DATE	OWN	APVD
		-	-	SEE SHEET 1	-	-	-

FEED TYPE

PNEUMATIC

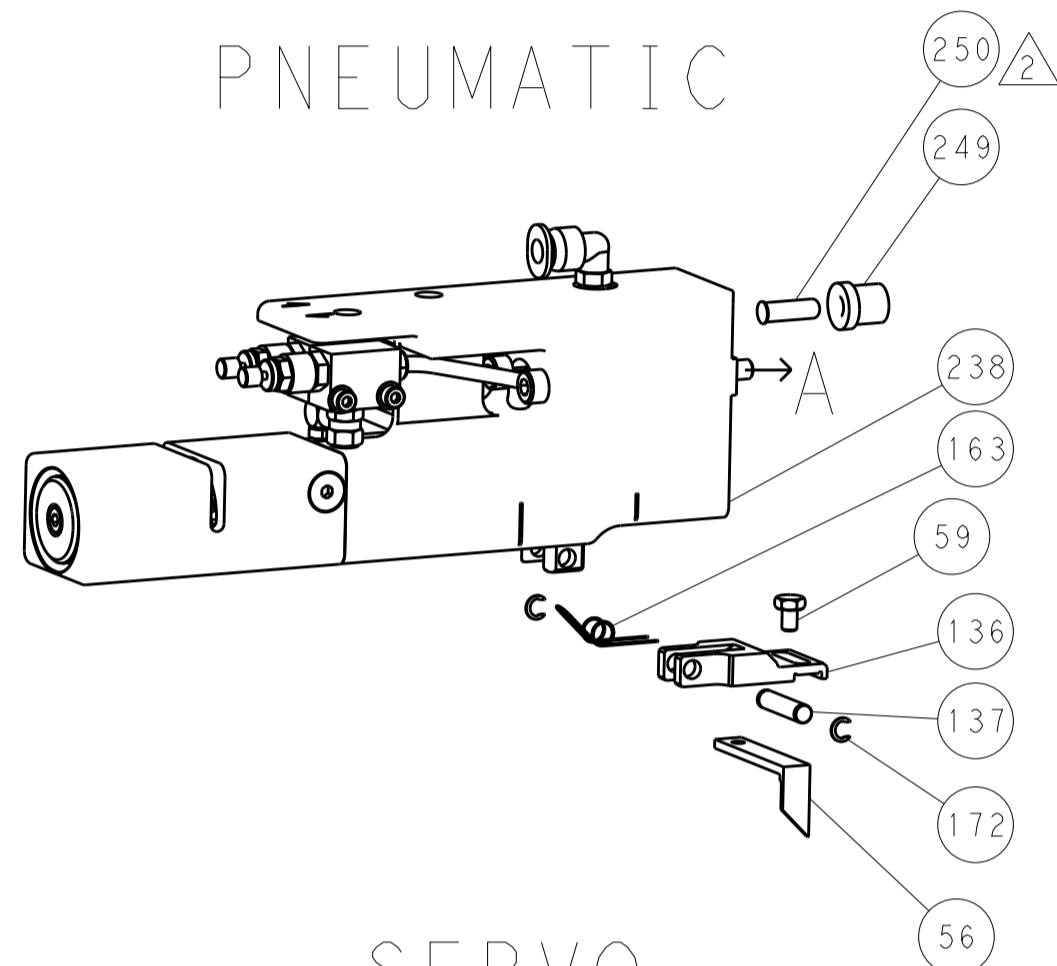

SERVO LATCH PLATE

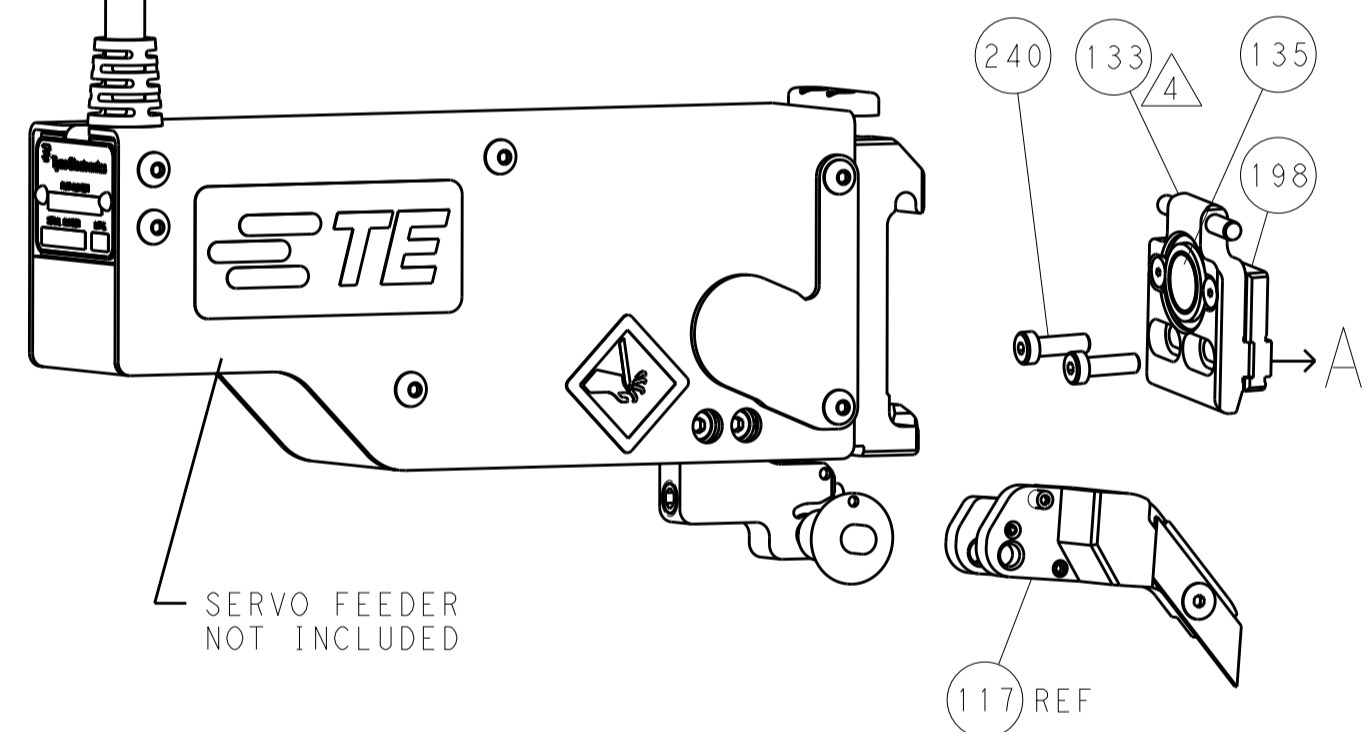

CAM POSITIONS

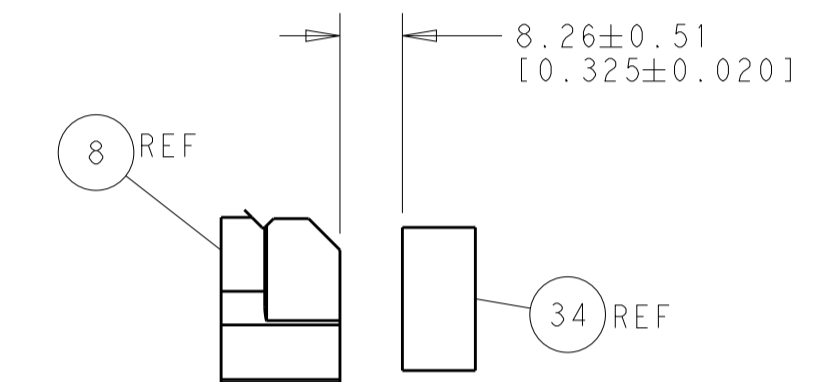
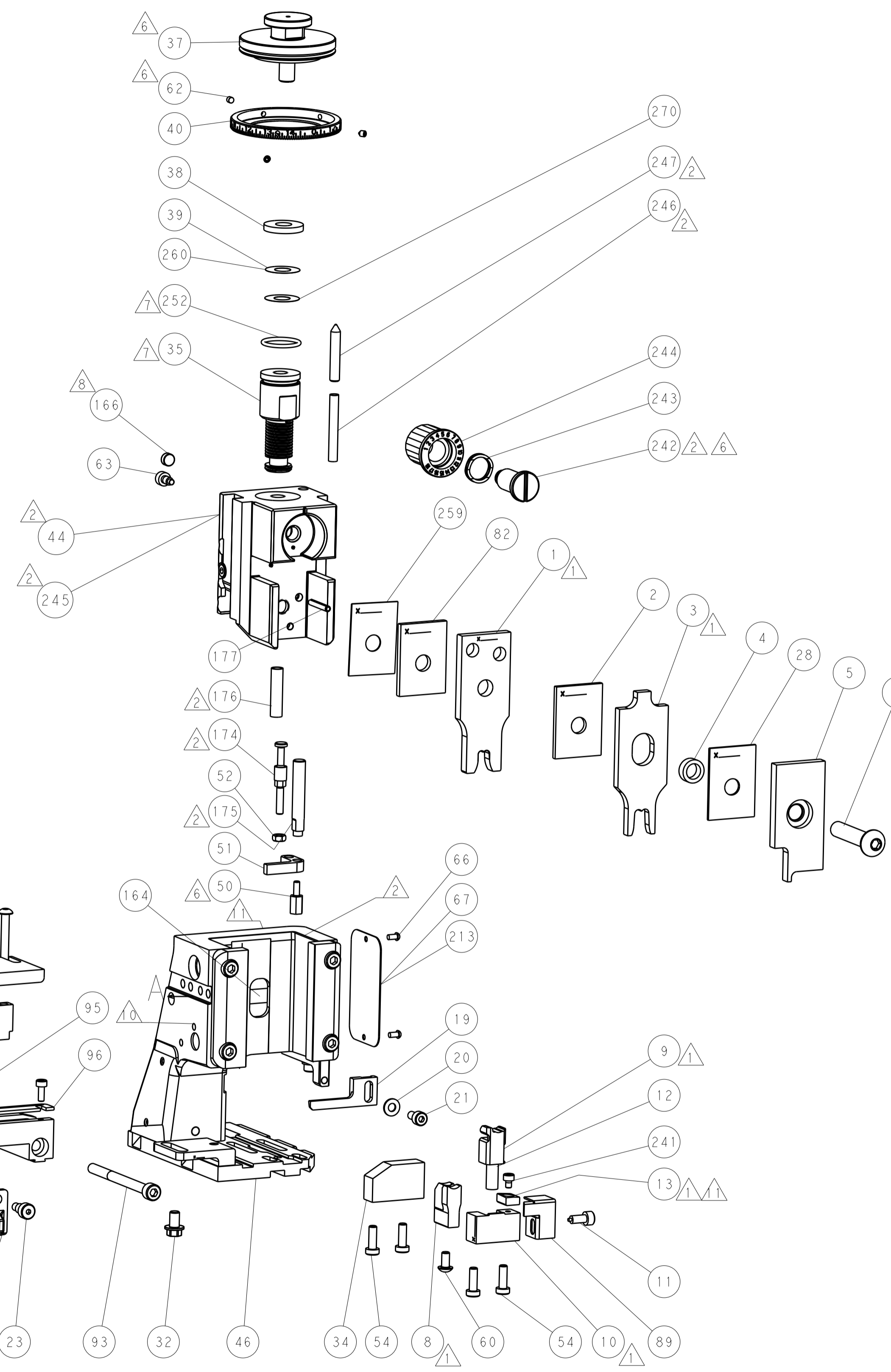
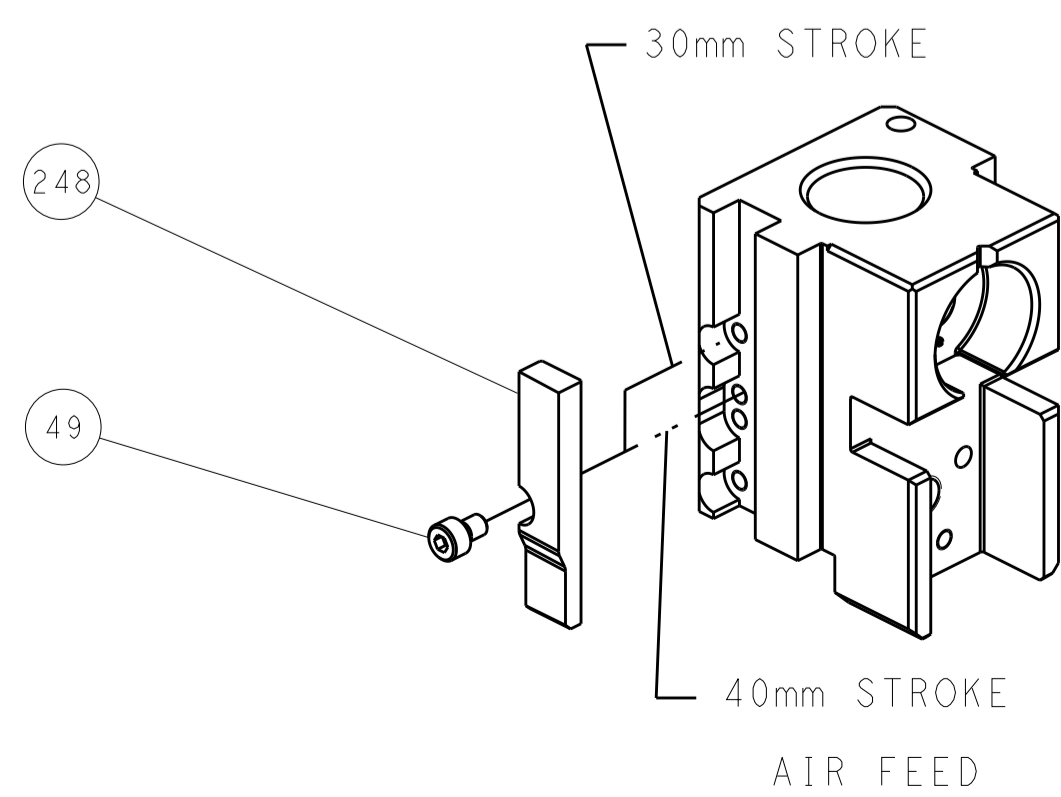

TERMINAL SUPPORT LOCATION

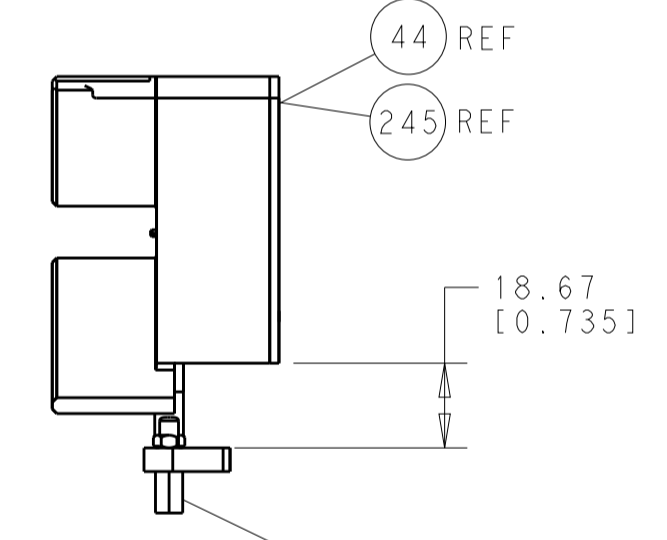

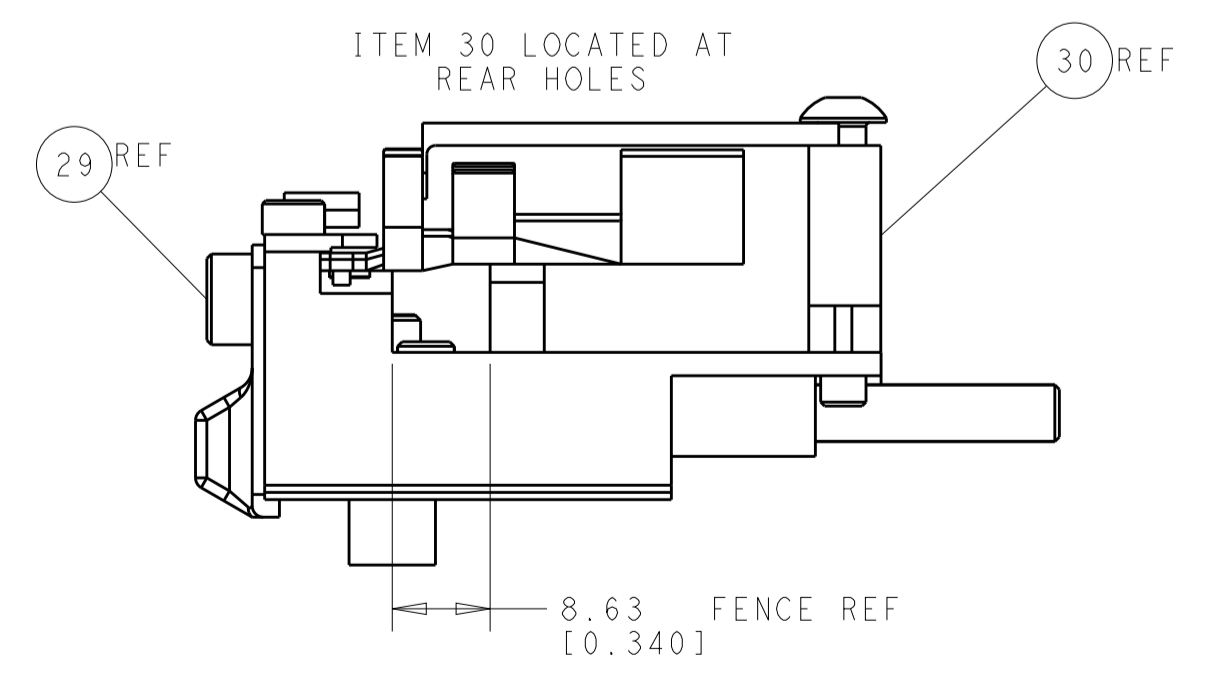

HOLDDOWN SET-UP



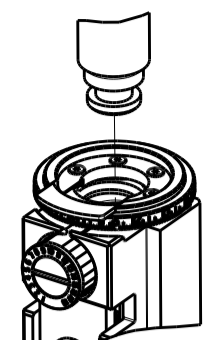

FEED TRACK POSITION GUIDE BY INSULATION BARREL

ATLANTIC VERSION
 Shown on sheets 1 of 4 & 2 of 4
 (Pacific version shown on sheets 3 of 4 & 4 of 4)





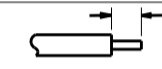



DIMENSIONS:		TOLERANCES UNLESS OTHERWISE SPECIFIED:		OWN: HOFFNER 12OCT2012		TE Connectivity	
mm	0 PLC ±0.1	1 PLC ±0.1	2 PLC ±0.02	3 PLC ±0.005	4 PLC ±0.0005	5 ANGLES ±0.0005	TE Connectivity Harrisburg, PA 17105-3608
MATERIAL:				APVD: T. ELBIN 15OCT2012		NAME: Ocean Side Feed Applicator	
FINISH:				WEIGHT:		SIZE: CAGE CODE: DRAWING NO: 00779 ©=2151760	
Customer Accessible Production Drawing				SCALE: 1:2		SHEET 2 OF 4 REV A	

PACIFIC VERSION TERMINATOR INTERFACE ADAPTER	PART NUMBER	REVISION	DESCRIPTION	FEED TYPE	APPLICATOR STYLE CONVERSION CHART					
					CONVERT TO	PART NUMBERS REQUIRED				
	2-2151760-2	A	FINE CRIMP HEIGHT ADJUST	PNEUMATIC	-	1338683-8	5-18022-5	-	-	-
					SERVO LATCH PLATE	2119951-1	8-2151760-5	1901094-3	2168400-6 (QUANTITY 2)	
	2-2151760-5	A	FINE CRIMP HEIGHT ADJUST	SERVO LATCH PLATE 	-	1338683-8	5-18022-5	-	-	-
					PNEUMATIC FEED	2119950-1	1338683-8	5-18022-5	2119641-2	2119799-1
2-2151760-7	A	FINE CRIMP HEIGHT ADJUST	NONE	-	-	-	-	-	-	
7-2151760-7	A	CRIMP TOOLING KIT	-	-	-	-	-	-	-	

APPLICATOR DATA		
CRIMP	SIZE	TYPE
WIRE	6.35 mm [.250]	F
INSUL	8.26 mm [.325]	F
APPLICATOR INSTRUCTIONS 408-10389 		

TERMINAL DATA: G&H Lear TERMINAL TE CRIMP SPECIFICATION			
TERMINAL NAME: TERMINAL			
WIRE STRIP LENGTH 5.50-7.00 mm [.217-.276 IN]		INSULATION DIAMETER RANGE Ø0.00-6.22 mm [.000-.245 IN]	
TERMINAL APPLICATION SPECIFICATION	NONE	-	-
TERMINALS APPLIED 			
TE TERMINAL 2113297-1	G&H Lear TERMINAL 26741.122.179	TE TERMINAL	G&H Lear TERMINAL

WIRE SIZE	CRIMP HEIGHT mm [INCH]	CRIMP HEIGHT REFERENCE SETTING
10.00mm ²	4.80 +/- 0.05 [.189 +/- .002]	1.2
6.00mm ²	3.76 +/- 0.05 [.148 +/- .002]	1.3.5

-  RECOMMENDED SPARE PARTS
-  GREASE BEARING SURFACES LIGHTLY
- 3. LUBRICATE DAILY PER THE APPLICATOR INSTRUCTION SHEET SUPPLIED WITH THE APPLICATOR.
-  APPLICATOR SPECIFIC DATA TO BE ENTERED INTO BLANK MEMORY CHIP AT ASSEMBLY. SEE BELOW FOR PART NUMBER:
 PNEUMATIC FEED WITH "SMART APPLICATOR" CONVERSION: 8-2151760-4
 SERVO FEED WITH "FINE CRIMP HEIGHT ADJUST": 8-2151760-5
- 5. ADJUSTMENT OF THE STRIPPER MAY BE REQUIRED WHEN MOVING THE APPLICATOR BETWEEN BENCH AND LEADMAKER APPLICATIONS.
-  APPLY PART NUMBER 1-23419-5 LOCTITE TO THREADS OF ITEM 50,62 & 242.
-  GREASE THREADS, GROOVE AND O-RING ON ITEMS 139 & 152.
-  MAGNET MUST BE ORIENTED CORRECTLY IN ORDER TO PROPERLY ACTUATE THE COUNTER.
-  CRIMP HEIGHT REFERENCE SETTING WAS THE SETTING USED WHEN THE APPLICATOR WAS QUALIFIED AT THE FACTORY. ADJUSTMENT MAY BE NECESSARY WHEN RUNNING APPLICATOR IN THE FIELD.
-  TERMINAL PITCH NOT COMPATIBLE WITH MECHANICAL FEED.
-  TO CONVERT THE APPLICATOR TO A NON-CARRIER CUTTING STYLE, REMOVE ITEM 13 AND ATTACH TO THE LOCATION ON BACK SIDE OF THE HOUSING. REFER TO INSTRUCTION SHEET FOR ADDITIONAL INFORMATION.
-  GRIND AT ASSEMBLY.

***WARNING**
 ON INSTALLATION, SET WIRE DISC, ITEM 40 TO LARGEST WIRE SIZE SETTING. USE OF SETTINGS BELOW MINIMUM REQUIRED CRIMP HEIGHT SETTING WILL CAUSE DAMAGE TO CRIMP TOOLING.

-	1	1	1	2119091-2	SHIM, LAMINATE	270
-	1	1	1	1633782-3	FENCE	267
-	1	1	1	455888-5	SPACER, CRIMPER	259
-	1	1	1	2119782-1	FINE ADJUST HEAD ASM, PACIFIC STYLE	251
-	-	-	1	2119640-1	PUSH ROD, AIR FEED	250
-	-	-	1	2079988-1	BUSHING, LCH5-12, MISUMI	249
-	1	1	1	1-22279-3	SPRING, COMPRESSION	246
-	1	1	1	2119082-9	CAM, SNAIL, INSULATION ADJUSTMENT	244
-	1	1	1	2079764-1	WASHER, WAVE SPRING, CREST-TO-CREST	243
-	1	1	1	2119083-1	RETAINER, INSULATION DIAL	242
-	1	1	1	7-18023-7	SCR, SKT HD CAP M3 X 4.0	241
-77	-27	-25	-22	PART NO	DESCRIPTION	ITEM NO

PACIFIC VERSION
 Shown on sheets 3 of 4 & 4 of 4
 (Atlantic version shown on sheets 1 of 4 & 2 of 4)

SET UP GAUGE	LOC	DIST	REVISIONS					
2119599-1	A	66	P	LTN	DESCRIPTION	DATE	OWN	APVD
-	-	-	-	-	SEE SHEET 1	-	-	-

-	-	2	-	2168400-6	SHCS, LOW HEAD, RoHS, M5 X 16	240
-	-	-	1	2063440-2	AIR FEED MODULE	238
-	-	-	1	2119740-2	TAG, IDENTIFICATION	213
-	-	-	1	1901094-3	SPACER, FEEDER	198
-	1	1	1	993111-1	PIN, SLOTTED SPRING 3.0 X 20.0	177
-	1	1	1	8-22280-7	SPRING, COMPRESSION	176
-	1	1	1	1752353-2	GUIDE PIN, HOLDDOWN	175
-	1	1	1	1901680-2	GUIDE PIN, HOLDDOWN	174
-	-	-	2	21045-3	RING, RETAIN, EXTERN, 3/16 CRESCENT	172
-	1	1	1	994969-1	MAGNET, RARE EARTH HIGH ENERGY	166
-	REF	REF	REF	994970-2	COUNTER, MAGNETIC	164
-	-	-	1	240638-1	SPRING, FEED FINGER	163
-	1	1	1	8-21084-1	O-RING, .801 ID, .070 DIA. MAT.	152
-	-	-	1	2119641-2	FEED CAM, AIR FEED	151
-	1	1	1	2119798-2	DETENT PIN	145
-	1	1	1	2079383-8	SCR, BHSC, RoHS (M4 X 16)	144
-	4	4	4	2168400-5	SHCS, LOW HEAD, RoHS, M4 X 20	143
-	1	1	1	1-2119656-0	APPLICATOR BASIC ASSEMBLY, SF	141
-	1	1	1	2161312-1	RAM, STEPPED, ASIAN STYLE, SIDE FEED	140
-	1	1	1	2119092-2	BOLT, ADJUSTMENT	139
-	-	-	1	3-23627-7	PIN, RETAIN, GRVD, 3/16 X .854	137
-	-	-	1	2119799-1	HOLDER, FEED FINGER, AF	136
-	-	REF	-	SEE NOTE 4	MEMORY CHIP, PROGRAMMED	135
-	-	-	1	1633743-1	SERVO FEED LATCH ASM	133
-	1	1	1	1-22281-8	SPRING, COMPRESSION	121
-	1	1	1	2-690438-2	FRONT STRIP GUIDE	96
-	4	4	4	2168083-1	SCR, SKT HD CAP, RoHS, M3 X 8.0	95
-	1	1	1	2168083-6	SCR, SKT HD CAP, RoHS, M5 X 65	93
-	1	1	1	318563-1	GUARD, FRONT CHIP	89
-	1	1	1	2-455888-7	SPACER, CRIMPER	82
-	1	1	1	2119956-1	DOCUMENTATION PACKAGE	71
-	1	-	1	2119740-1	TAG, IDENTIFICATION	67
-	2	2	2	2168078-1	SCREW, DRIVE, RH, RoHS	66
-	1	1	1	2119793-1	LIMITER, ADJUSTMENT BOLT	63
-	3	3	3	992763-5	SCR, SET, SOC, CONE POINT, M3 x 4.0	62
-	2	2	2	2-18032-5	SCR, SET, FLT POINT M5 X 20.0	61
-	-	-	1	5-18022-5	SCR, HEX HD CAP, M4 X 6.0	59
-	-	-	1	1-1338683-1	FEED PAWL	56
-	1	1	1	1-5018030-0	NUT, HEX, REG, RoHS, M3.5	52
-	1	1	1	1901681-2	HOLDDOWN, TERMINAL	51
-	1	1	1	2-1752354-1	STANDOFF, HOLD-DOWN	50
-	-	-	1	18023-9	SCR, SKT HD CAP M4 X 6.0	49
-	1	1	1	1-2079383-5	SCR, BHSC, RoHS (M8 X 40)	41
-	1	1	1	2119645-1	DISC, NUMBERED FA WIRE ADJUSTMENT	40
-	1	1	1	2119957-1	APPLICATOR SHIM PACK	39
-	1	1	1	2119644-8	RAM WASHER, PRECISION	38
-	1	1	1	3-1752356-3	SUPPORT, TERMINAL	34
-	2	2	2	1-2079383-3	SCR, BHSC, RoHS (M4 X 25)	33
-	1	1	1	2161328-1	HEX HEAD, FLANGED, M5 x 8mm LONG	32
-	1	1	1	2-1320908-5	SPACER, STRIP GUIDE	30
-	1	1	1	1901086-9	PLATE, STRIP GUIDE	29
-	1	1	1	1-455888-0	SPACER, CRIMPER	28
-	2	2	2	22281-9	SPRING, COMPRESSION	27
-	1	1	1	356835-1	LEVER, DRAG RELEASE	26
-	1	1	1	240792-1	DRAG, TERMINAL	25
-	1	1	1	1320928-6	STRIP GUIDE	24
-	1	1	1	980371-4	SCR, SKT HD SHLDR 5.0 DIA X 6.0	23
-	1	1	1	2168083-2	SCR, SKT HD CAP, RoHS, M4 X 8.0	21
-	1	1	1	1-18028-2	WASHER, FLAT, REG M4	20
-	1	1	1	2119533-2	STRIPPER, SIDE FEED	19
-	1	1	1	2119806-1	INSERT, SHEAR	13
-	1	1	1	3-22280-3	SPRING, COMPRESSION	12
-	1	1	1	1-356885-3	STOP, SHEAR	11
-	1	1	1	2119805-1	SHEAR HOLDER, FRONT	10
-	1	1	1	318707-8	FLOATING SHEAR, FRONT	9
-	1	1	1	1633929-1	ANVIL, COMBINATION	8
-	-	-	-	-	-	7
-	-	-	-	-	-	6
-	1	1	1	1-2119757-3	DEPRESSOR, SHEAR	5
-	1	1	1	238011-3	BLOCK, CRIMPER SPACER	4
-	1	1	1	5-1633961-7	CRIMPER, INSULATION F PREMIUM	3
-	1	1	1	2-455888-2	SPACER, CRIMPER	2
-	1	1	1	456432-8	CRIMPER, WIRE	1
-77	-27	-25	-22	PART NO	DESCRIPTION	ITEM NO

DIMENSIONS: mm		TOLERANCES UNLESS OTHERWISE SPECIFIED:		DWG: HOFFNER 12OCT2012		CHK: T. ELBIN 15OCT2012		APVD: T. ELBIN 15OCT2012		NAME: Ocean Side Feed Applicator	
0 PLC ±.1		1 PLC ±.05		2 PLC ±.02		3 PLC ±.005		4 PLC ±.0005		SIZE: A	
MATERIAL: -		FINISH: -		WEIGHT: -		SCALE: 1:2		SHEET: 3 OF 4		REV: A	

Customer Accessible Production Drawing

LOC		DIST		REVISIONS			
A	66	P	LTH	DESCRIPTION	DATE	OWN	APVD
		-		SEE SHEET 1			

FEED TYPE

PNEUMATIC

SERVO LATCH PLATE

CAM POSITIONS

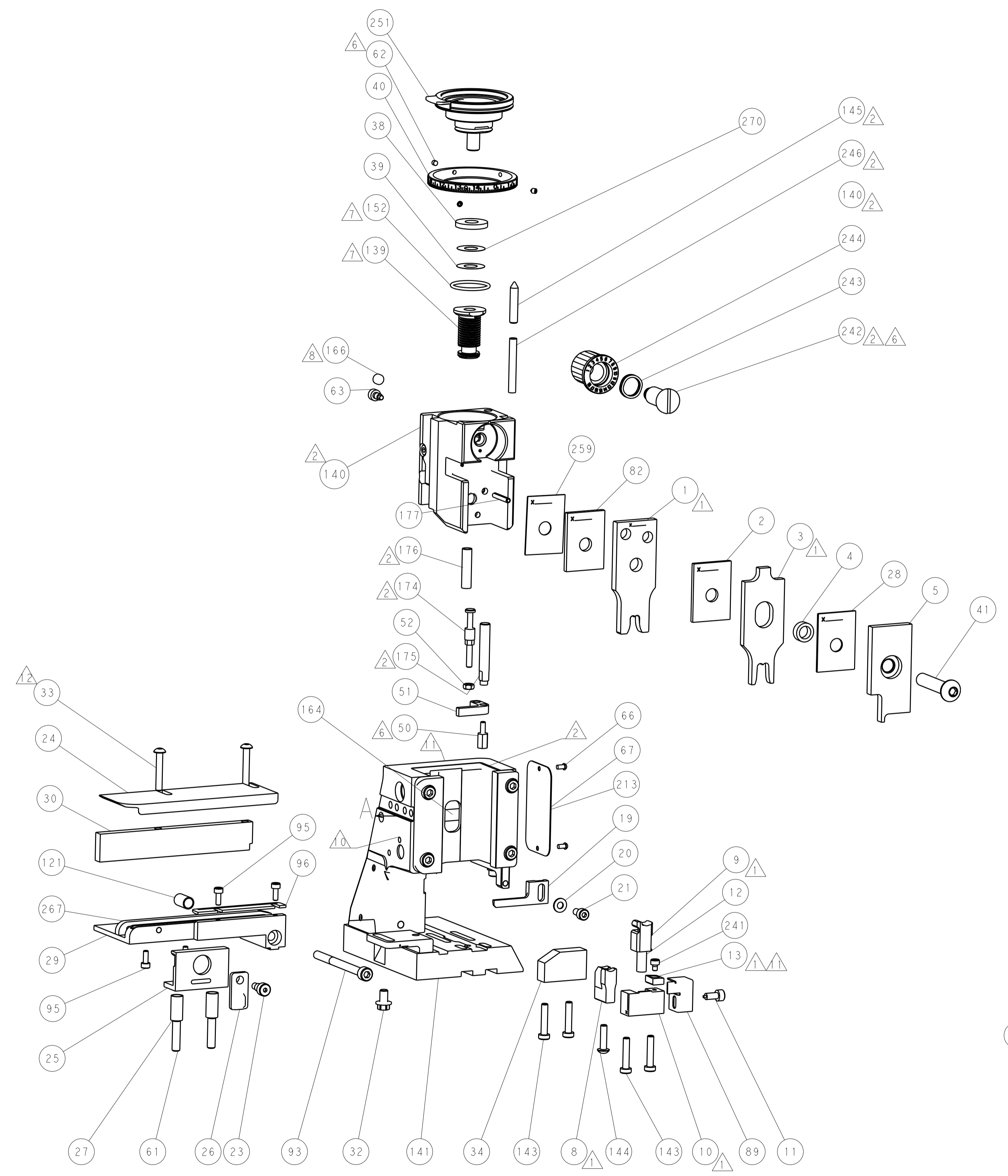
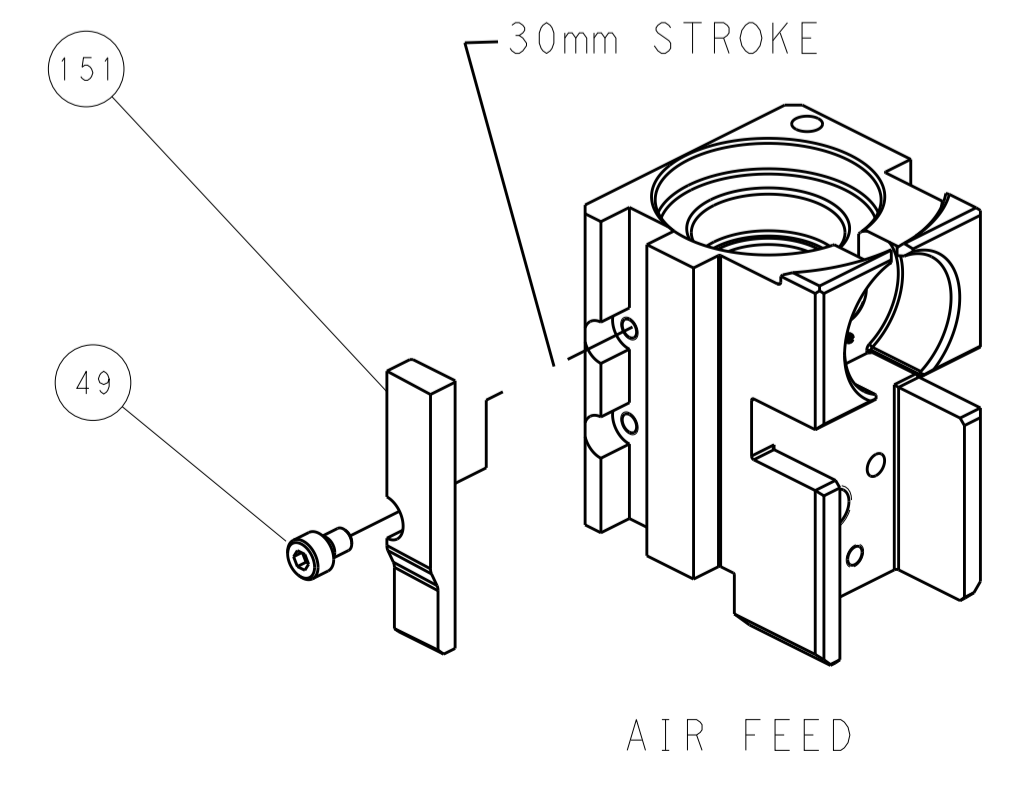
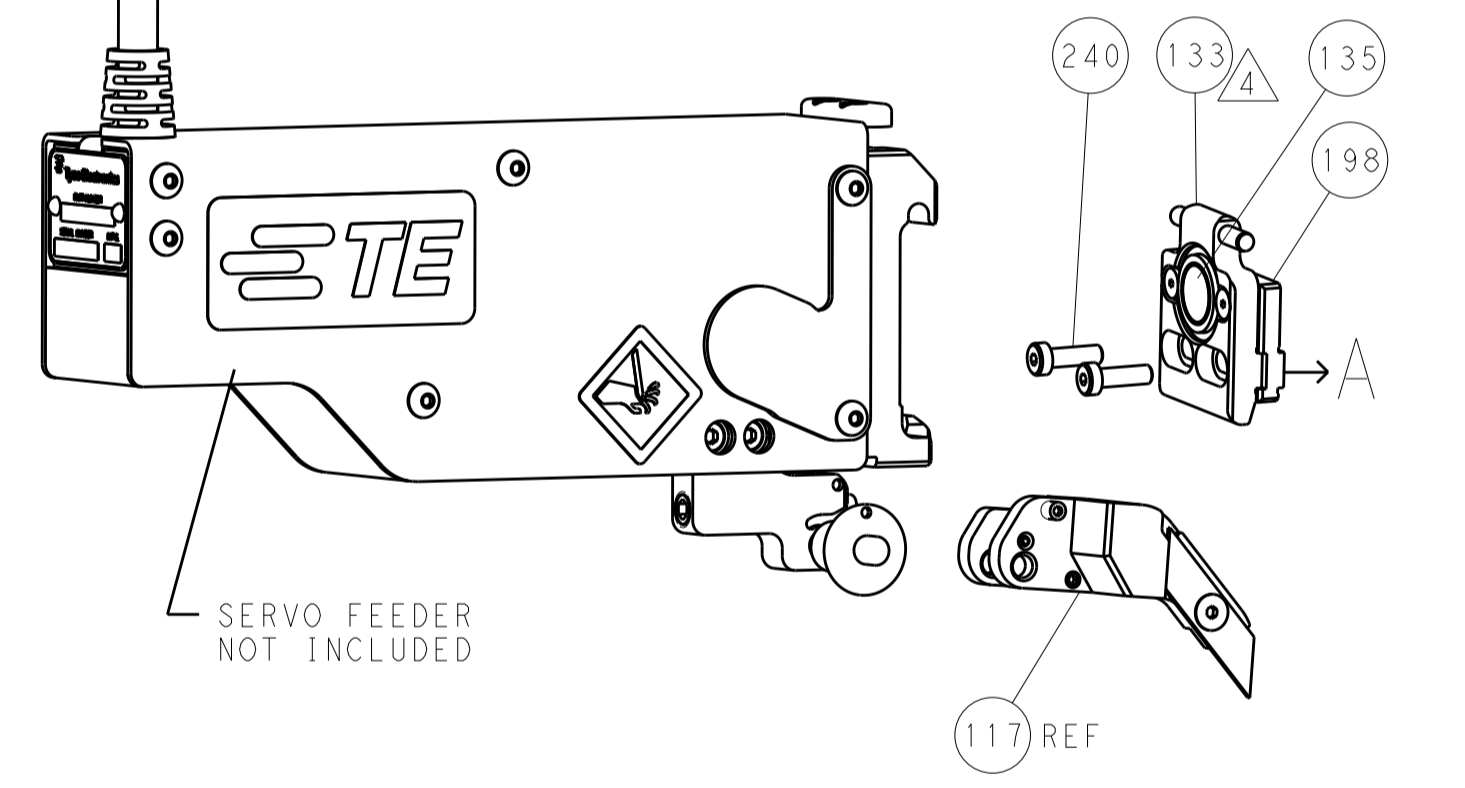
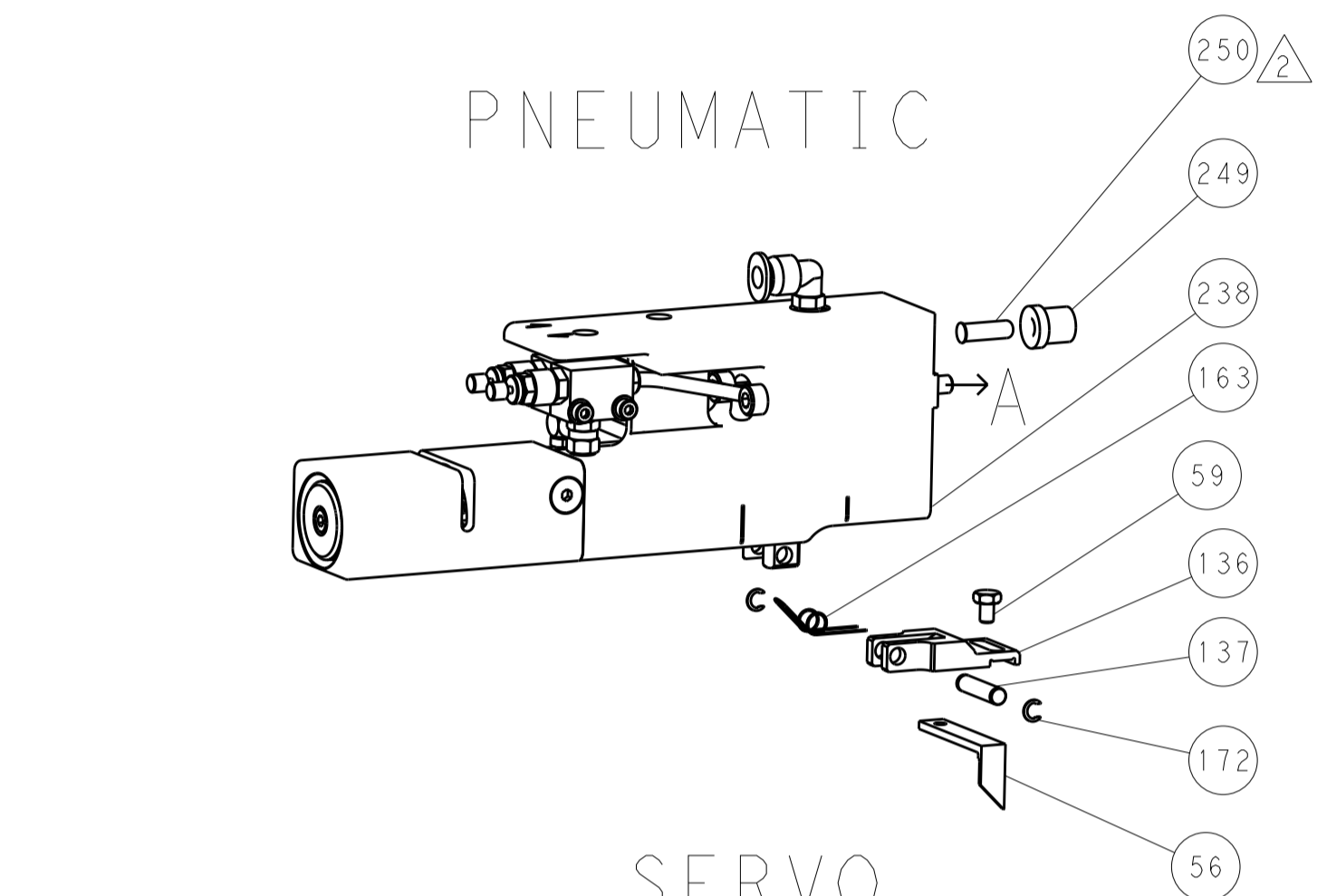

8.26±0.51
[0.325±0.020]

TERMINAL SUPPORT LOCATION

18.67
[0.735]

HOLDDOWN SET-UP

ITEM 30 LOCATED AT REAR HOLES

8.63 FENCE REF
[0.340]

FEED TRACK POSITION GUIDE BY INSULATION BARREL

PACIFIC VERSION
 Shown on sheets 3 of 4 & 4 of 4
 (Atlantic version shown on sheets 1 of 4 & 2 of 4)

DIMENSIONS:		TOLERANCES UNLESS OTHERWISE SPECIFIED:		DWN: HOFFNER 12OCT2012		TE Connectivity	
mm	0 PLC ±0.1	1 PLC ±0.1	2 PLC ±0.02	3 PLC ±0.005	4 PLC ±0.0005	ANGLES ±	FINISH
MATERIAL:				CAGE CODE: 00779		DRAWING NO: 2151760	
Customer Accessible Production Drawing				SCALE: 1:2		SHEET 4 OF 4 REV A	