

THE INFORMATION CONTAINED HEREIN IS CONSIDERED
 "PROPRIETARY" TO BEL FUSE INC. AND SHALL NOT BE
 COPIED, REPRODUCED OR DISCLOSED WITHOUT THE
 WRITTEN APPROVAL OF BEL FUSE INC.

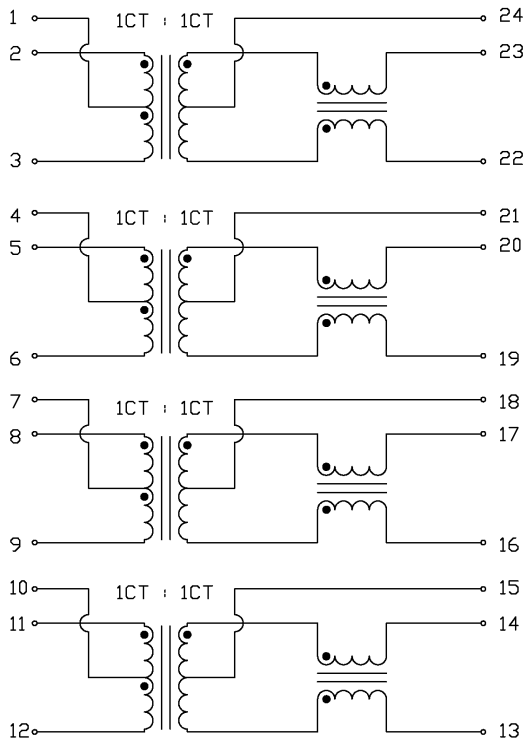

SCHEMATIC



ELECTRICAL CHARACTERISTICS @25°C

URNS RATIO	1CT : 1CT
PHASE	2 TO 23, 5 TO 20, 8 TO 17, 11 TO 15 IN PHASE
OCL :	350uH MIN. AT 100kHz, 100mV (2-3), (5-6), (8-9), (11-12) WITH 8mA DC BIAS, FROM 0 -70°C
INSERTION LOSS	1.0dB MAX. @ 1MHz TO 100MHz 1.5dB MAX. @ 125MHz
RETURN LOSS	18dB MIN. @ 1-30MHz MEASURED UNDER A 100 Ω I/O 15dB MIN. @ 60MHz 12dB MIN. @ 80MHz 10dB MIN. @ 100MHz
CROSSTALK	10-100 MHz 35 dB MIN.
COMMON TO COMMON REJECTION	30 dB MIN. AT 100kHz TO 155MHz
HIPOT	PER HAND-WORK-03

ORIGINATED BY	DATE	TITLE	PART NO. / DRAWING NO.	STANDARD DIM.	[] METRIC DIM. AS REFERENCE	
HD	04-03-06	ELECTRICAL SPECIFICATION S558-5999-AZ-F	X5585999AZ-F	TOL. IN INCH	UNIT : INCH [mm]	REV. : A
DRAWN BY	DATE		FILE NAME	.X	SCALE : N/A	SIZE : A4
DQ Chen	04-03-06		X5585999AZFA.DWG	.XX	PAGE : 2	
				.XXX		



THE INFORMATION CONTAINED HEREIN IS CONSIDERED "PROPRIETARY" TO BEL FUSE INC. AND SHALL NOT BE COPIED, REPRODUCED OR DISCLOSED WITHOUT THE WRITTEN APPROVAL OF BEL FUSE INC.

RoHS
2002/95/EC



SUGGESTED PCB PAD LAYOUT

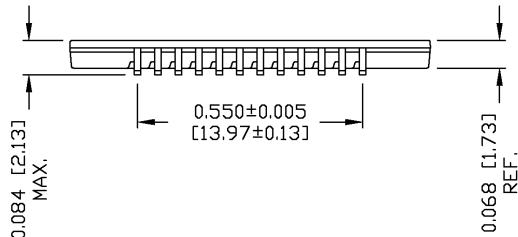
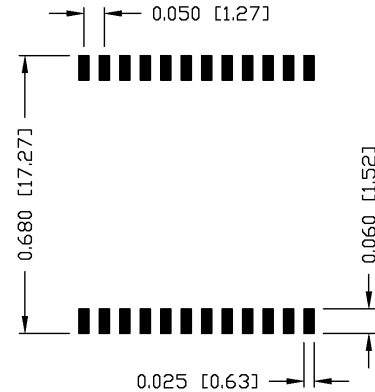
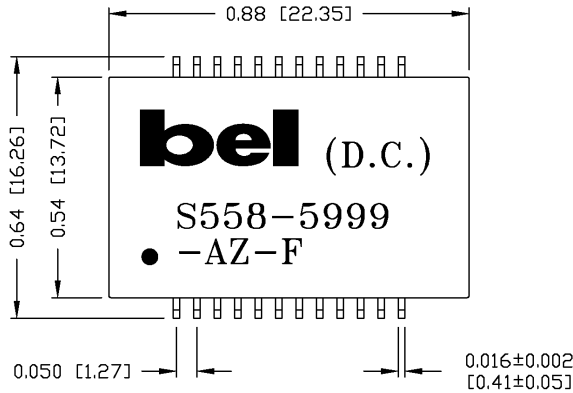

BETWEEN COMPONENTS AND INTERNAL LEADS TO SEATING PLANE WITH 0.002" MIN CLEARANCE

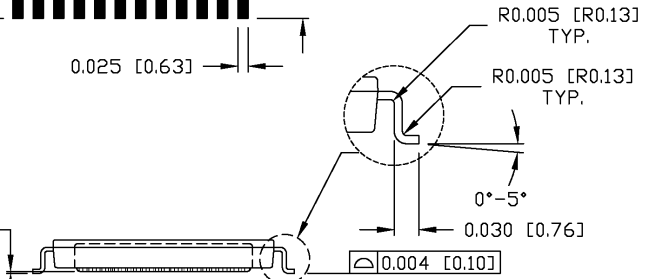

NOTES:

- STANDARD MARKING REFER TO DOC. HAND-WORK-04.
- PACKAGE CODE: "RJS001".

ORIGINATED BY	DATE	TITLE	PART NO. / DRAWING NO.	STANDARD DIM. TOL. IN INCH	[] METRIC DIM. AS REFERENCE	<p>COMPONENTS FOR A CONNECTED PLANE</p>	
Lawrence	04-03-06	MECHANICAL DRAWING S558-5999-AZ-F	X5585999AZ-F	.X	UNIT : INCH [mm]		REV. : A
DRAWN BY	DATE		FILE NAME	.XX	SCALE : N/A		SIZE : A4
DQ Chen	04-03-06		X5585999AZFA.DWG	.XXX	±0.01		PAGE : 3
					±0.005		