

**Four-LED Strings, High Efficiency White LED Driver for LCD Backlighting****General Description**

The AAT1451 is a highly integrated, high efficiency LED backlight solution for notebook, netbook computers, monitors and portable TVs. The device operates from DC inputs, cigarette adapters and single to multi-cell Li-ion batteries in the voltage range from 2.7V to 26V.

An integrated boost (step-up) converter provides a high voltage output up to 50V for driving series LEDs. Four precision current sinks are programmable up to 30mA per string through one external  $R_{SET}$  resistor, supporting up to 48<sup>1</sup> white LEDs at 120mA total output current.

The boost output voltage is determined by the highest total forward voltage of the LED strings, allowing for a wide range of LED characteristics. Each string is PWM dimmed with 90 degree phase shift to minimize ripple currents, and filter capacitor sizes. The PWM input frequency range is 100Hz to 10kHz with a dimming range of 256:1.

The integrated boost regulator switching frequency is programmable from 600kHz to 1MHz by external resistor for optimum efficiency and the smallest external L/C filtering components.

Boost current mode control provides fast response to line and load transients. Integrated light-load mode ensures highest efficiency across the entire load range.

Fault tolerant circuitry extends system life by disabling open and shorted LED(s) strings. The unique high voltage current sinks prevent damage resulting from shorted LEDs. The  $\overline{FAULT}$  pin indicates the presence of shorted LEDs or over-temperature conditions.

The AAT1451 is available in a Pb-free, thermally enhanced 16-pin 3x4 TDFN package.

**Features**

- $V_{IN}$  Range: 2.7V to 26V
- Integrated 50V Boost Converter
  - Maximum  $I_{OUT}$ : 120mA
  - Programmable Switching Frequency
    - 600kHz to 1MHz
  - Up to 93% Efficiency
  - High Efficiency Light-Load Mode
- Four White LED Strings
  - Programmable Max Current Sink up to 30mA Each
  - $\pm 2\%$  Accuracy (22mA)
  - $\pm 1.5\%$  Matching (22mA)
- Direct PWM Dimming
  - Automatic Phase Shifting
  - Fast Turn-On/Off
- Integrated Fault Protection for
  - Independent Disable of Open/Shorted LED(s) String(s)
  - Over-Voltage
  - Over-Temperature
- $\overline{FAULT}$  Indication for Shorted LED(s) and Over-Temperature
- Soft-Start Minimizes Inrush Current
- TDFN34-16 Low Profile Package
- -40°C to +85°C Temperature Range

**Applications**

- Tablets
- Notebook and Netbook Computers
- Portable Media Players
- Monitors

1. The maximum number of LEDs in each string is dependent upon the maximum  $V_F$  of the diodes in that string. Under no event should the absolute maximum voltage at SW be exceeded.

# AAT1451

## Four-LED Strings, High Efficiency White LED Driver for LCD Backlighting

### Typical Application Circuit ( $V_{IN} = 2.7V$ )

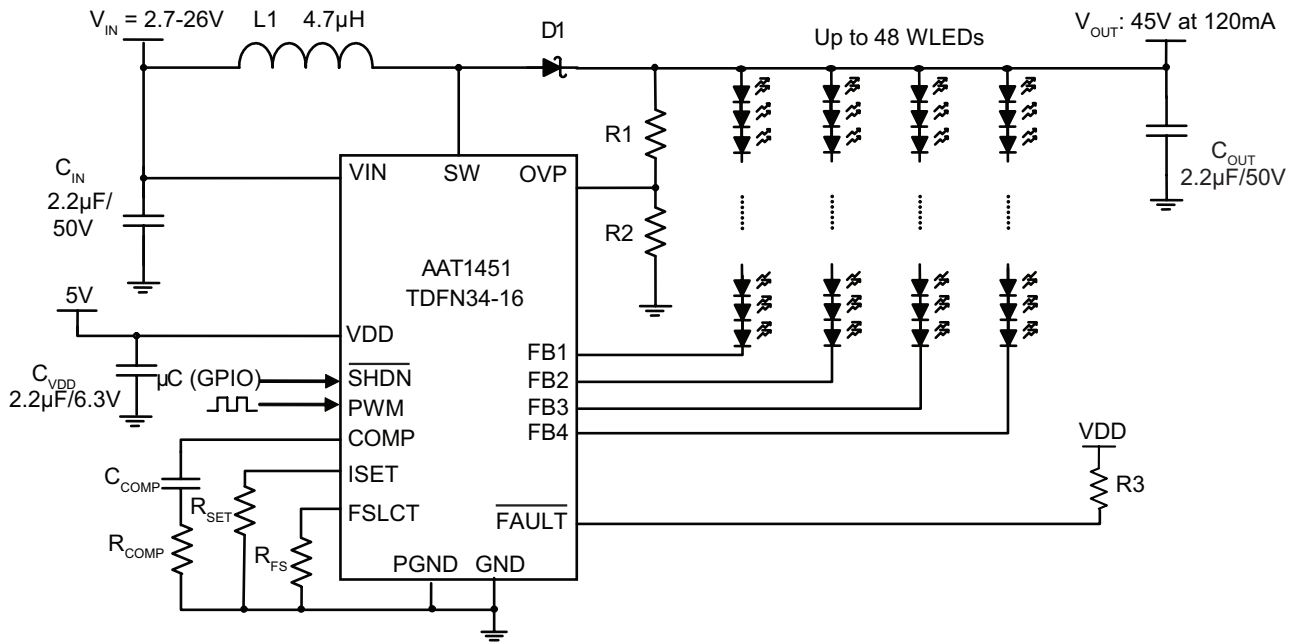

### Typical Application Circuit ( $V_{IN} = 5.0V$ )

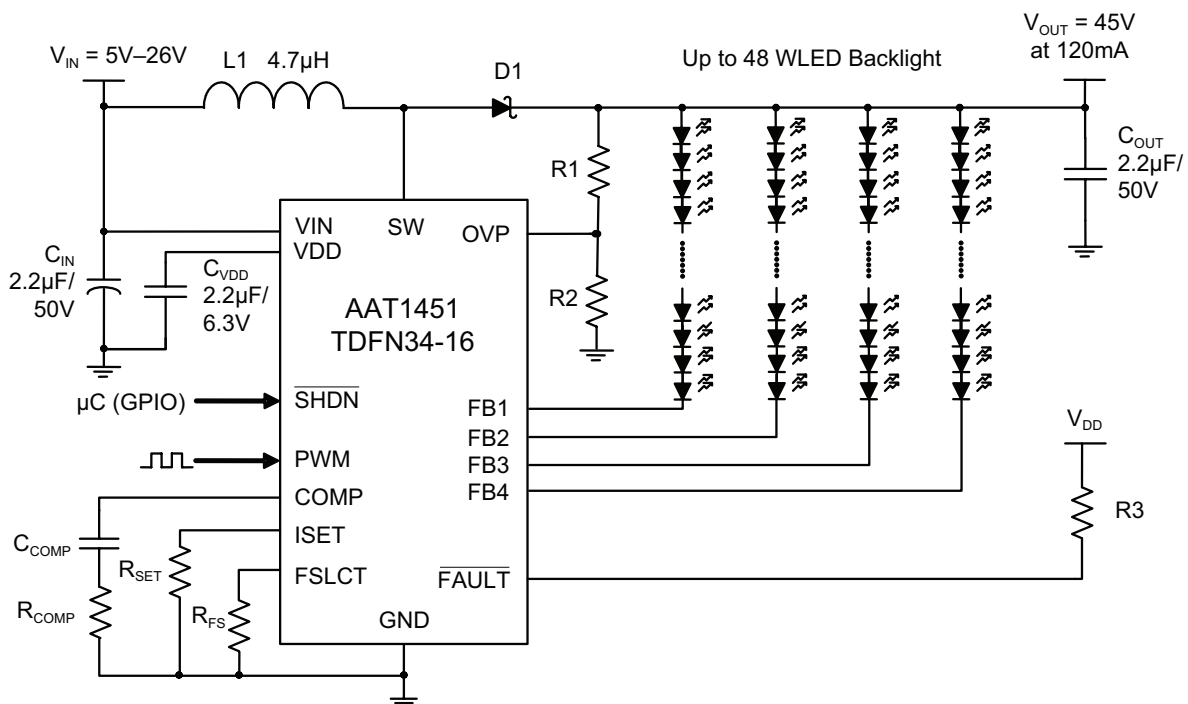

**Four-LED Strings, High Efficiency White LED Driver for LCD Backlighting****Pin Descriptions**

Pin #	Symbol	Function	Description
1	PGND	GND	Power Ground. Connect to GND underneath the IC.
2	VIN	I	Input voltage to IC. Tied to input voltage source and input boost inductor.
3	FSLCT	I	Connect an external resistor to set boost switching frequency from 600kHz to 1MHz.
4	ISET	I	Connect resistor to ground to set maximum current up to 30mA through the LED strings.
5	FB1	O	Output current sink 1. Connect to GND to disable channel 1.
6	FB2	O	Output current sink 2. Connect to GND to disable channel 2.
7	FB3	O	Output current sink 3. Connect to GND to disable channel 3.
8	FB4	O	Output current sink 4. Connect to GND to disable channel 4.
9	$\overline{\text{FAULT}}$	O	Open drain $\overline{\text{FAULT}}$ signal. Pull up to VDD with external resistor. Low indicates a shorted LED condition.
10	VDD	I/O	Internal regulated voltage when operating from input voltage range 5.0V to 26.0V. De-couple with a 2.2 $\mu$ F capacitor to ground. Do not source current from this node. Connect to 5.0V rail when operating from $V_{IN}$ less than 5.0V.
11	PWM	I	PWM input pin. Connect logic level PWM input signal in the frequency range 100Hz-10kHz to this pin to enable PWM dimming.
12	$\overline{\text{SHDN}}$	I	Logic high to enable the device. Logic low disables the device and minimizes quiescent current and also disables the internal linear regulator.
13	COMP	I	Connect an external resistor in series with a capacitor to ground to compensate the boost converter.
14	AGND	AGND	Connect to AGND
15	OVP	I	Over-voltage protection pin. Connect to output of boost converter through a resistor divider.
16	SW	O	Switching node of boost converter. Connect an inductor between this pin and input voltage source. Connect the Schottky diode between this pin and boost output capacitor.
EP		PGND	Exposed paddle. Connect to PCB PGND plane. Input and output capacitor GND should connect to EP.

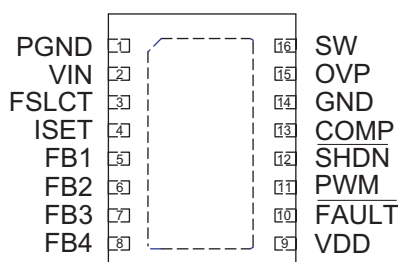
**Pin Configuration****TDFN34-16  
(Top View)**

**Four-LED Strings, High Efficiency White LED Driver for LCD Backlighting****Absolute Maximum Ratings<sup>1</sup>**

Symbol	Description	Value	Units
$V_{SW}$	Voltage to GND	50	V
$V_{IN}$	Input Voltage to GND	-0.3 to 30	
$V_{FBx}$	Output Current Sinks FB1 – FB4 to GND	-0.3 to 40	
$V_{DD}, V_{FAULT}$	Low Voltage Pin to GND	-0.3 to 7.0	
SHDN, COMP, PWM, ISET, FSLCT, OVP	Voltage to GND	-0.3 to $V_{DD} + 0.3$	
$I_{OUT}$	Maximum DC Output Current <sup>2</sup>	134	mA
$T_J$	Maximum Junction Operating Temperature	-40 to +150	°C
$T_{LEAD}$	Maximum Soldering Temperature (at leads, 10 sec.)	300	
$P_D$	Maximum Power Dissipation <sup>3</sup>	2	W
$\theta_{JA}$	Thermal Resistance <sup>3,4</sup>	50	°C/W

**Recommended Operating Conditions**

Symbol	Description	Value	Units
$V_{IN}$	Input Voltage Range	5 to 26	V
$V_{OUT}$	Output Voltage Range	$V_{IN} + 3$ to 45	
$F_{PWM}$	PWM Dimming Frequency Range	0.1 to 10	kHz
$T_A$	Operating Ambient Temperature	-40 to 85	°C
$T_J$	Operating Junction Temperature	-40 to 130	

1. Stresses above those listed in Absolute Maximum Ratings may cause permanent damage to the device. Functional operation at conditions other than the operating conditions specified is not implied.

2. Based on long-term current density limitation.

3. Mounted on an FR4 board.

4. Derate 20mW/°C above 25°C.

## Four-LED Strings, High Efficiency White LED Driver for LCD Backlighting

Electrical Characteristics<sup>1</sup>

$V_{IN} = 12V$ ;  $C_{IN} = 2.2\mu F$ ,  $C_{OUT} = 2.2\mu F$ ;  $C_{VDD} = 2.2\mu F$ ;  $L_1 = 4.7\mu H$ ;  $R_{SET} = 7.5k\Omega$  ( $I_{FBx} = 22mA$ );  $R_{FSCLT} = 20k\Omega$ ;  $T_A = -40^\circ C$  to  $85^\circ C$  unless otherwise noted. Typical values are at  $T_A = 25^\circ C$ .

Symbol	Description	Conditions	Min	Typ	Max	Units
<b>Power Supply, Current Sinks</b>						
$V_{IN}$	Input Voltage Range		5.0		26.0	V
$V_{UVLO}$	Under-Voltage Threshold	$V_{IN}$ Rising			4.3	V
		Hysteresis		500		mV
		$V_{IN}$ Falling	3.2			V
$V_{DD}$	VDD Output Voltage	SHDN = Logic High, $I_{DD(OUT)} = 0mA$	4.0	4.5	6.0	V
$V_{FBx}$	Current Sink Voltage	SHDN = Logic High, $I_{FBx} = 22mA$ ( $R_{SET} = 7.5k\Omega$ )		0.3		V
$V_{FBx(SHORT)}$	Shorted Diode(s) Detection Threshold	$I_{FBx} = 30mA$		5		V
$I_Q$	IN Quiescent Current	FB1-FB4 = Open, SHDN = Logic low		3		mA
$I_{SD}$	IN Pin Shutdown Current	FB1-FB4 = Open, SHDN = $V_{PWM} =$ Logic low, does not include SW leakage current			40.0	$\mu A$
$I_{FBx}$	Current Sink Accuracy	$I_{FBx} = 22mA$ , $T_A = 25^\circ C$	-5	$\pm 2$	+5	%
$I_{FBx-Matching}$	Current Matching Between Any Sink Channel	$I_{FBx} = 22mA$	-2	$\pm 1.5$	+2	%
$V_{OVP}$	Over Voltage Threshold	$V_{OUT}$ Rising	1.1	1.2	1.3	V
	Over Voltage Hysteresis	$V_{OUT}$ Falling		100		mV
$R_{DS(ON)LO}$	Low Side Switch ON Resistance	$V_{DD} = 4.5V$		500		$m\Omega$
$D_{MAX}$	Maximum Duty Cycle		90			%
$T_{MIN}$	Minimum On-Time			100		ns
$V_{ISET}$	Voltage at ISET			0.6		V
$V_{FSCLT}$	Voltage at FSCLT			0.6		V
$I_{FBx} / I_{RSET}$	Current Set Ratio	$I_{FBx}/I_{ISET}$ , $V_{ISET} = 0.6V$		264		A/A
$I_{LIMIT}$	Low Side Switch Current Limit	$V_{IN} = 5.0V$ to $26.0V$	3.0		5.0	A
$I_{LEAK}$	SW Pin Leakage	SHDN = Logic Low, $V_{SW} = 45V$			1	$\mu A$
	FBx Pin Leakage	$V_{FBx} = 30V$ , $V_{PWM} =$ logic high			10	$\mu A$
$F_{OSC}$	Oscillator Frequency	$R_{FS} = 20k\Omega$	850	1000	1150	kHz
$F_{PWMI(MAX)}$	Maximum Input PWM Frequency <sup>1</sup>		100		10000	Hz
$F_{PWMO(MAX)}$	Maximum Output PWM Frequency		6750	8000	9250	Hz
$T_{SS}$	Soft-Start Time	$V_{OUT} = 35V$ , $C_{COMP} = 18nF$ , $R_{COMP} = 10k\Omega$		1.5		ms
<b>Logic Level Inputs: SHDN, PWM</b>						
$V_{LSHDN}$	SHDN Threshold Low				0.4	V
$V_L$	PWM Threshold Low				0.8	V
$V_H$	PWM and SHDN Threshold High		2.2			V
$I_{LK}$	SHDN, PWM Input Leakage Current	$V_{PWM} = V_{SHLD} = V_{DD}$		10		$\mu A$
$D_{PWMI}$	Input PWM Duty Cycle		0		99	%
<b>FAULT Output</b>						
$V_{FAULTLOW}$	FAULT Logic Output Low	$I_{SINK} = 1mA$			0.4	V
$I_{FAULT}$	FAULT Leakage Current	$V_{FAULT} = 3.3V$ , No Faults		$\pm 1$		$\mu A$
<b>Thermal Protection</b>						
$T_{J(SD)}$	$T_J$ Thermal Shutdown Threshold			150		$^\circ C$
$T_{J(SD-HYS)}$	$T_J$ Thermal Shutdown Hysteresis	Maintains previous dimming setting		15		$^\circ C$

1. The AAT1451 is guaranteed to meet performance specifications over the  $-40^\circ C$  to  $+85^\circ C$  operating temperature range and is assured by design, characterization, and correlation with statistical process controls.

2. Output voltage must result in a voltage lower than the SW maximum ratings under all operating conditions.

## Four-LED Strings, High Efficiency White LED Driver for LCD Backlighting

### Typical Characteristics

**Boost Efficiency vs Input Voltage**  
(L = 4.7μH; V<sub>DD</sub> = 5V; PWM = 5V; I<sub>OUT</sub> = 30mA/ch)

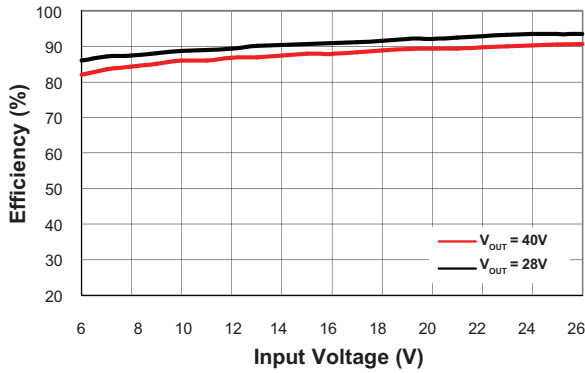

**Boost Efficiency vs Load Current**  
(L = 4.7μH; V<sub>DD</sub> = 5V; PWM = 5V; I<sub>OUT</sub> = 30mA/ch)

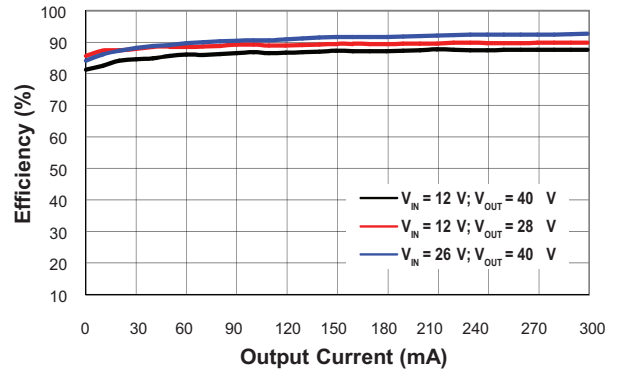

**Boost Efficiency vs PWM Duty Cycle**  
(L = 4.7μH; V<sub>DD</sub> = PWM = 5V; I<sub>OUT</sub> = 30mA/ch)



**Output Current vs PWM Duty Cycle**  
(V<sub>IN</sub> = 12V; I<sub>OUT</sub> = 30mA/ch)

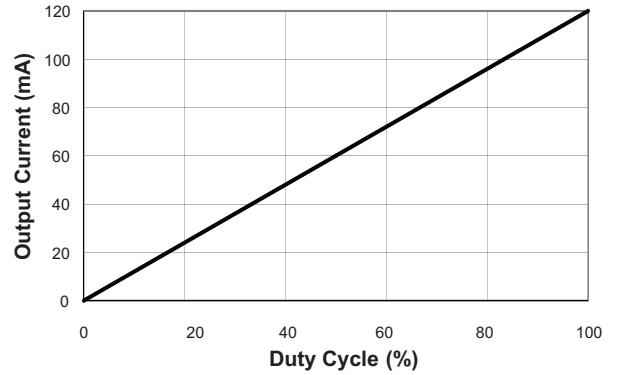

**UVLO vs Temperature**

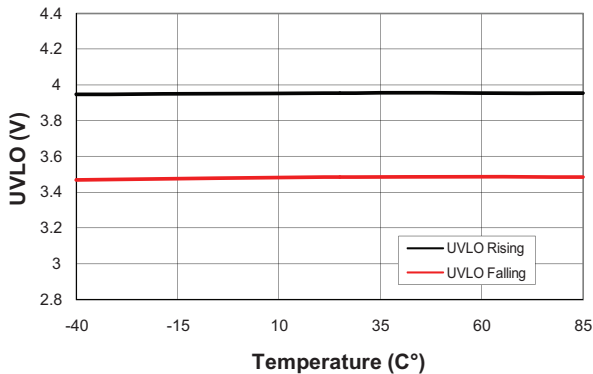

**Current Limit vs Temperature**

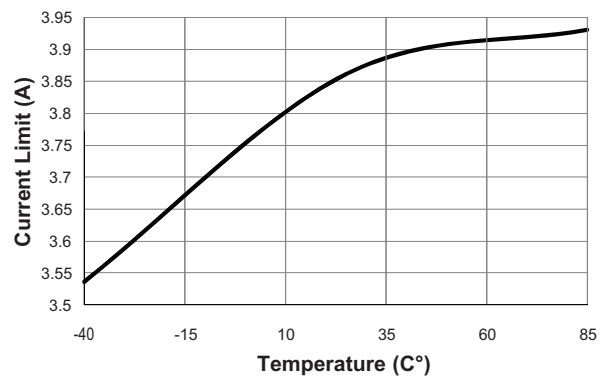

## Four-LED Strings, High Efficiency White LED Driver for LCD Backlighting

### Typical Characteristics

**Quiescent Current vs Input Voltage**  
(Non-Switching)

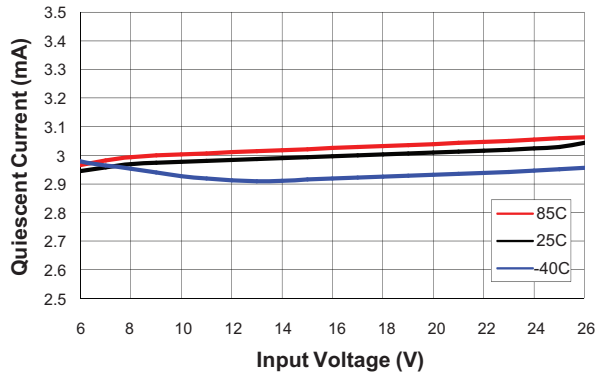

**VDD Line Regulation vs Input Voltage**

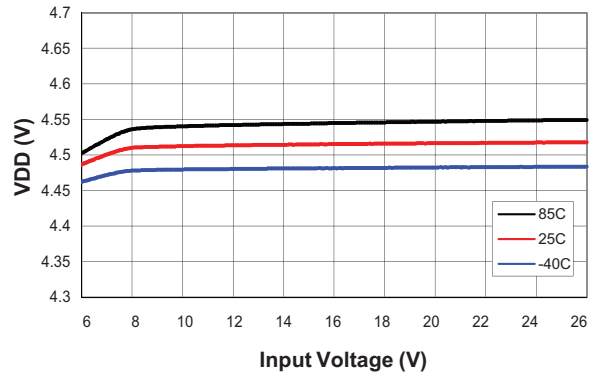

**Shutdown Current vs Input Voltage**

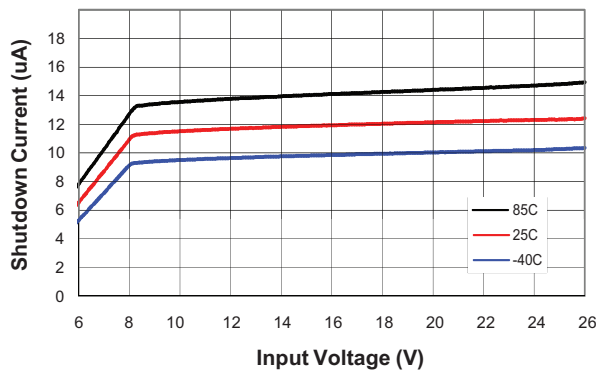

**Frequency vs Temperature**  
( $V_{IN} = 12V$ )

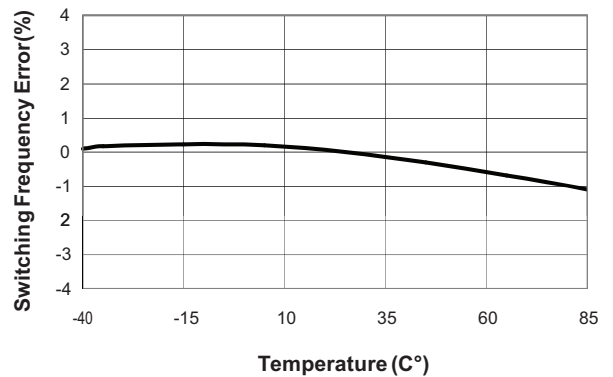

**Current Sink Accuracy vs Temperature**  
( $V_{IN} = 12V$ ; 30mA/ch)

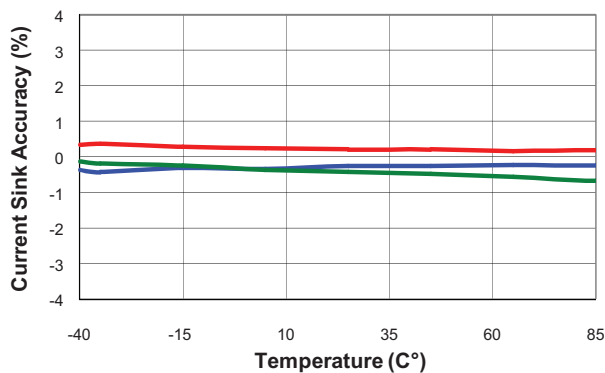

**Current Sink Matching vs Temperature**  
( $V_{IN} = 12V$ ; 30mA/ch)

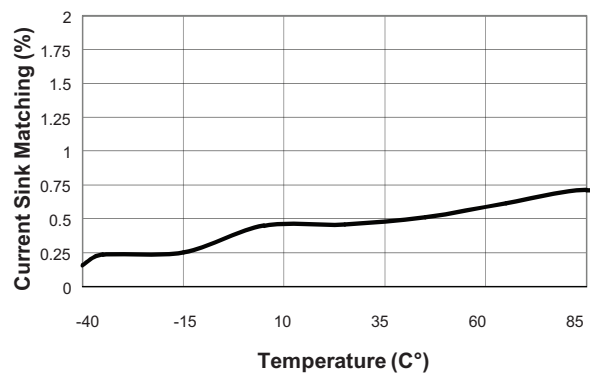

## Four-LED Strings, High Efficiency White LED Driver for LCD Backlighting

### Typical Characteristics

Over Voltage Threshold vs Temperature  
 $V_{IN}=12V$

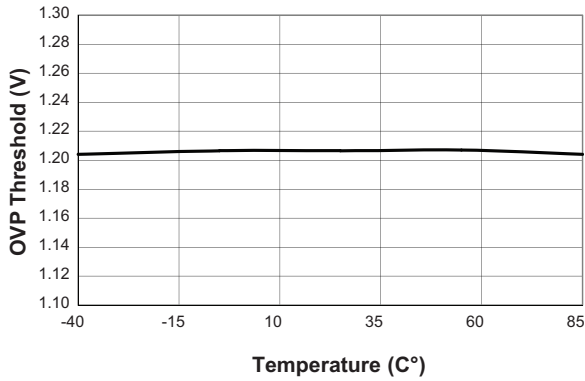

Low Side Switch On Resistance vs Temperature

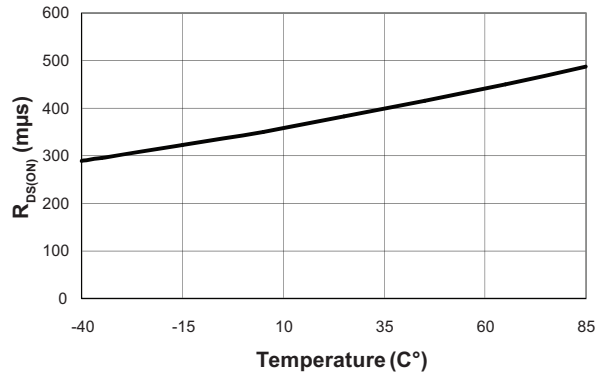

Enable High Threshold Voltage vs. Input Voltage

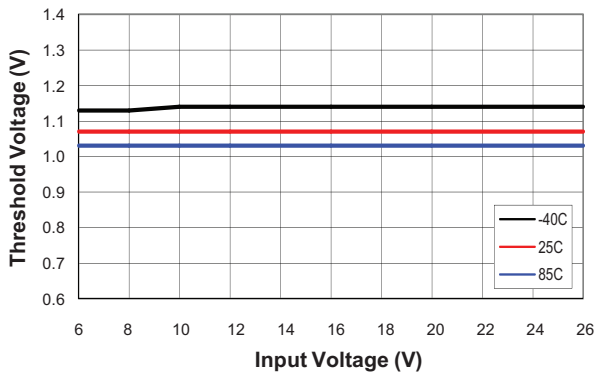

PWM,  $F_{SET}$  Logic Low Threshold Voltage vs. Input Voltage

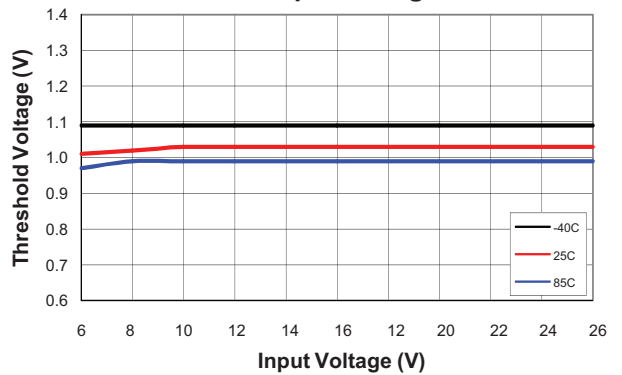

Switching Waveforms

( $V_{IN} = 12V$ ;  $V_{OUT} = 37V$ ;  $I_{OUT} = 80mA$ )

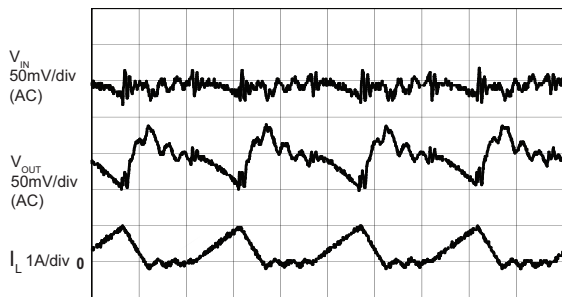

Time (400ns/div)

Start UP

( $V_{IN} = 12V$ ;  $V_{OUT} = 40V$ ;  $I_{OUT} = 65mA$ ; Duty Cycle = 50%)

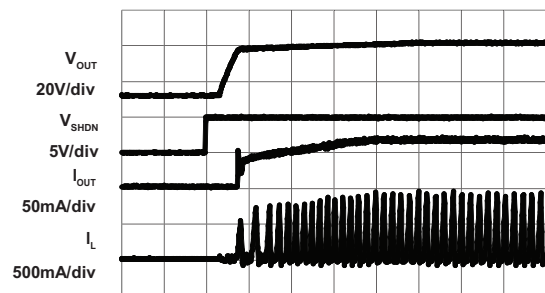

Time (2ms/div)



## Typical Characteristics

**PWM Switching Waveforms**  
( $V_{IN} = 12V$ ;  $V_{OUT} = 40V$ ; Duty Cycle = 30%)

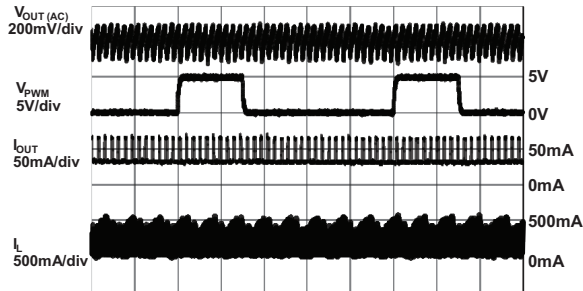

Time (200µs/div)

**PWM Switching Waveforms**  
( $V_{IN} = 12V$ ;  $V_{OUT} = 40V$ ; Duty Cycle = 80%)

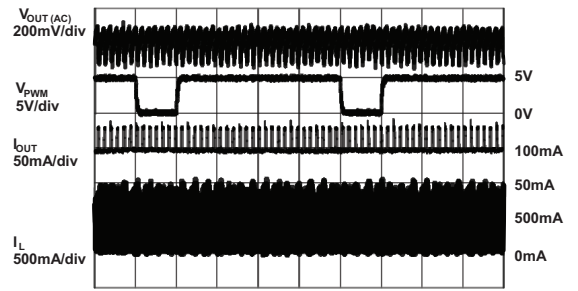

Time (200µs/div)

**PWM Switching Waveforms**  
( $V_{IN} = 12V$ ;  $V_{OUT} = 40V$ ; Duty Cycle = 50%)

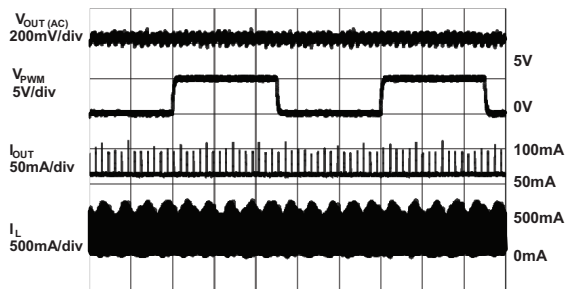

Time (200µs/div)

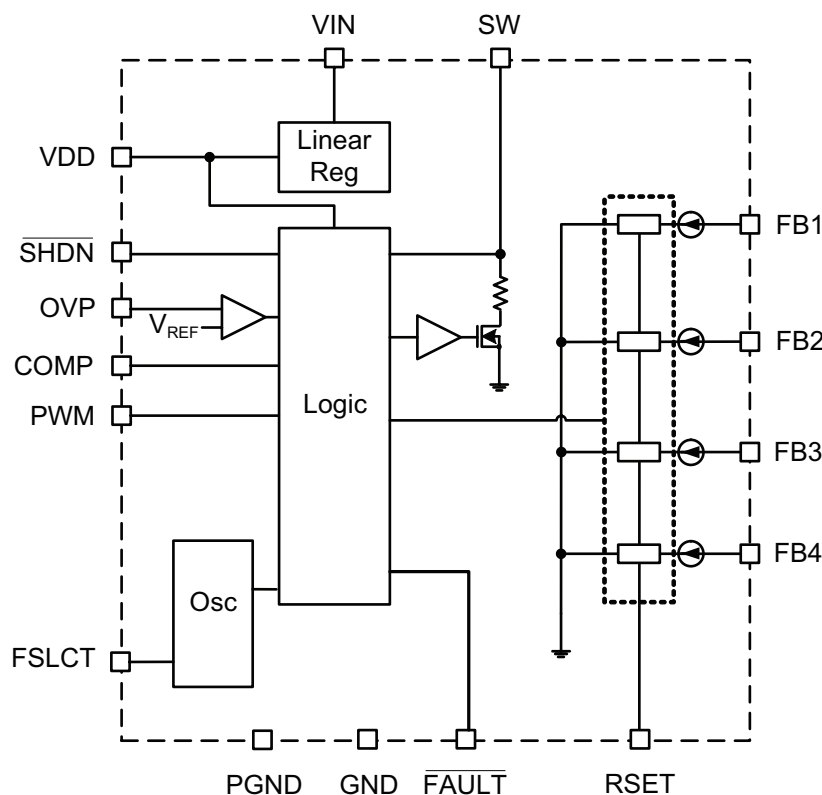
**Four-LED Strings, High Efficiency White LED Driver for LCD Backlighting****Functional Block Diagram****Functional Description**

The AAT1451 adopts a synchronous peak current detect step-up structure to drive up to 48 white LEDs with up to 30mA each (120mA total) for backlight solutions. The controller derives output feedback from the lowest sink voltage of the four LED sink channels while maintaining the programmed current accuracy and matching. This ensures the lowest possible output voltage, highest efficiency, and continuous operation with mismatched LED strings. LED dimming is controlled by an external 100Hz to 10kHz PWM signal. The LED current is on/off with fixed frequency of 8kHz with the same duty cycle as the PWM signal. This feature, together with the phase shifting feature, makes it easy to filter the LED current switching noise on the output when designing the system.

The AAT1451 is designed for maximum flexibility allowing unused current sinks to be disabled by connecting them to ground. The unique high voltage current sinks support non-matching LED strings (LED quantity, type, etc.)

The boost switching frequency is programmable from 600kHz up to 1MHz by external resistor for optimum efficiency and the smallest external filter components. Current mode control provides fast response to line and load transients. Integrated light-load mode ensures high-efficiency across the entire input voltage and load range.

The AAT1451 integrates several fault protection features to deal with LED opens/shorts and thermal faults. Fault tolerant circuitry extends system life by disabling current sinks with open LEDs. The high voltage current sinks maintain normal operation with non-matched strings while also preventing damage due to shorted LEDs. When all LED sinks are open, the over voltage protection is active to prevent the boost output voltage from becoming too high by disabling power MOSFET switching when the OVP voltage threshold is exceeded.

Boost switching is re-enabled when OVP hysteresis is satisfied. Over-current protection prevents inductor saturation and any resulting damage to the switching device occurring during an overload fault condition.

## Four-LED Strings, High Efficiency White LED Driver for LCD Backlighting

### Boost Converter Switching Frequency

The AAT1451's boost converter frequency can be adjusted between 600kHz to 1MHz using an external resistor ( $R_{FS}$ ). For maximum accuracy, a 1% tolerance resistor is recommended.

Please refer to Table 1 and Figure 1 for  $R_{FS}$  resistor values.

$$R_{FS} = \frac{2 \cdot 10^{10}}{F_{SW}}$$

$R_{FS}$ (k $\Omega$ )	Frequency (kHz)
20	1000
22	909
24	833
26	769
28	714
30	667
33	606

**Table 1: Examples of Standard 1%  $R_{FS}$  Values for Setting Switching Frequency.**

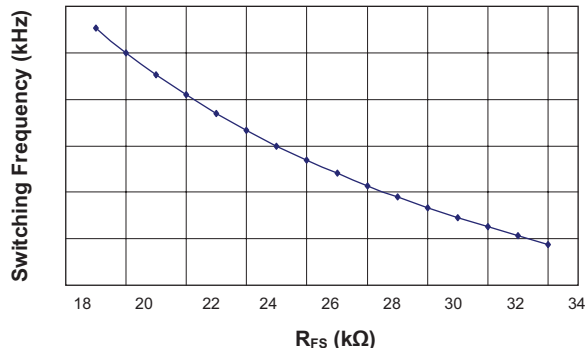

**Figure 1: Switch Frequency vs.  $R_{FS}$**

### Maximum LED Current Selection

The current sink is controlled by the internal reference voltage ( $V_{ISET}$ ) and the external resistor ( $R_{SET}$ ) at the ISET pin. The maximum LED current programmable range is from 15mA to 30mA by  $R_{SET}$ . For maximum accuracy, a 1% tolerance resistor is recommended.

The  $R_{SET}$  value can be calculated as follows:

$$R_{SET} = \frac{\text{CurrentSetRatio} \cdot V_{ISET}}{I_{FB}}$$

Where CurrentSetRatio = 264 and  $V_{ISET} = 0.6V$ .

For example, if the maximum current for each string LEDs is 30mA, this corresponds to a minimum resistor of 5.23 k $\Omega$ .

$$R_{SET} = \frac{264 \cdot 0.6V}{30mA} = 5.23k\Omega$$

Maximum LED Current (mA)	$R_{SET}$ (k $\Omega$ )
30	5.23
25	6.34
22	7.5
20	7.87
15	10.5

**Table 2: Examples of Standard 1%  $R_{SET}$  Values for Setting Maximum LED Current Levels.**

Please also refer to Figure 2 for quickly choosing a  $R_{SET}$  value.

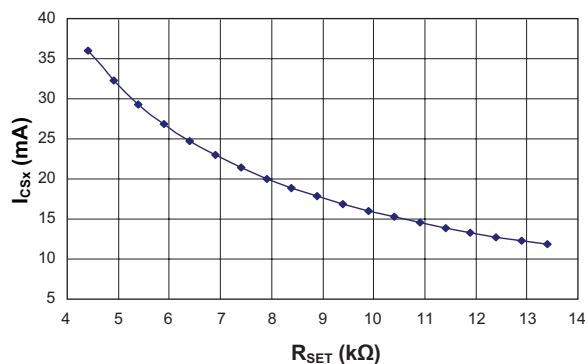

**Figure 2: Choosing an  $R_{SET}$  Value**

**Four-LED Strings, High Efficiency White LED Driver for LCD Backlighting****PWM Dimming**

The AAT1451 uses a simple PWM interface to control the effective LED current (RMS) at the current sinks. The PWM signal should fit the requirements listed in the electrical characteristic table for proper operation. After initial power-up and  $\overline{\text{SHDN}}$  is pulled to high together with PWM high, the device is enabled with 100% brightness as determined by the  $R_{\text{SET}}$  resistor value. For example, when the PWM pin is constantly pulled high, which means 100% duty ratio, the current per channel is typically 30mA with  $R_{\text{SET}} = 5.3\text{k}\Omega$ . By feeding the PWM pin with a proper PWM signal, the RMS current of each sink is proportional to the duty ratio of the PWM signal. Table 3 shows the average LED current of each channel at maximum 22mA as the PWM duty cycle change.

The AAT1451 integrates a clock hunting circuitry to derive the external PWM signal duty cycle to generate same duty cycle LED current on/off between the maximum current value and 0mA with fixed 8kHz frequency. It can work bi-directionally when the PWM signal increases or decreases to determine the duty cycle.

PWM Duty Cycle	FB1 - FB4 Current (mA) ( $R_{\text{SET}} = 7.5\text{k}\Omega$ )
100%	22
95%	20
90%	19
85%	18
80%	17
75%	16
70%	15
65%	14
60%	13
55%	12
50%	11
45%	9
40%	8
35%	7
30%	6
25%	5
20%	4
15%	3
10%	2
5%	1

**Table 3: AAT1451 PWM Duty Cycle vs. LED Current at Maximum 22mA Setting**

**PWM Duty vs WLED Current  
AAT1451**

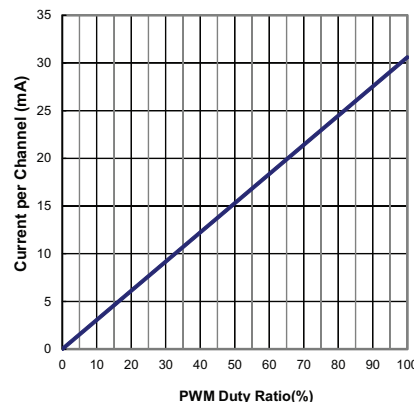

**Figure 3: PWM Duty Cycle vs. LED Current at Maximum 30mA Setting.**

**Automatic Phase Shift PWM**

The AAT1451 has implemented an automatic phase shift PWM mechanism for FB1-FB4 current sources. It will automatically detect the number of operating channels and phase shift each channel, "n", by  $\Theta_n$  relative to the PWM input.

The phase shift  $\Theta$  and delay time  $T_D$  are defined as:

$$\Theta_n = \frac{360 \cdot (n - 1)}{N}$$

$$T_D = \frac{T_{\text{PWM}}}{N}$$

Where N is the number of operating channels, and n is the target channel.

The FB1-FB4 timing diagram is shown in Figure 4 to elaborate the automatic phase shift working waveform.

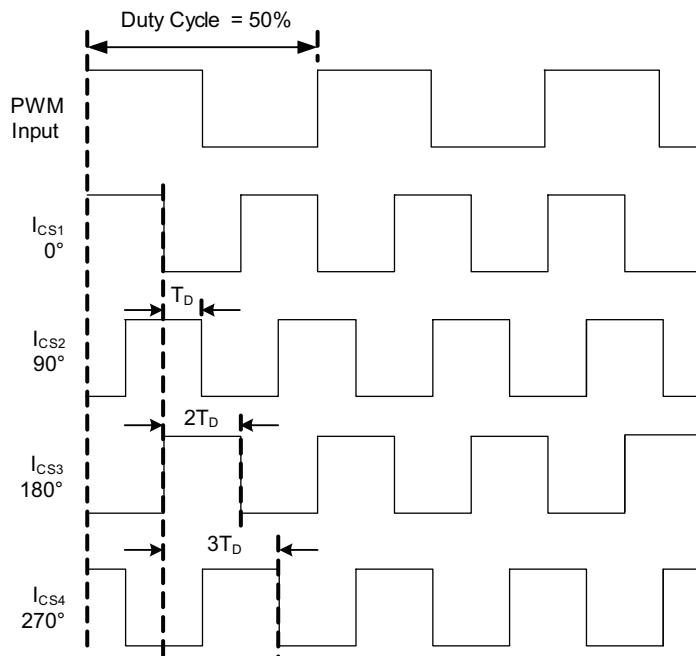
**Four-LED Strings, High Efficiency White LED Driver for LCD Backlighting**

**Figure 4: AAT1451 Automatic Phase Shift PWM Timing Diagram**

### **Open LED Protection and FAULT Indication for Shorted LEDs**

The AAT1451 device is protected from faults arising from LED opens and shorts.

An open LED(s) condition will be detected by the controller at startup. The low voltage is detected by the controller which disables the given current sink. The remaining LED strings continue to operate normally. The controller re-enables the disabled current sink in the event that the LED open condition is removed during a power cycle or  $\overline{SHDN}$  cycle. This feature extends backlight life and reliability.

Under the condition that PWM duty cycle is less than 100%, shorted LEDs condition results in a higher voltage appearing on the affected channels' current-sink pin. The affected current sink automatically compensates for the additional voltage. This current sink can withstand a high voltage indefinitely. However, the increased voltage across the current sink causes an increase in power dissipation. The AAT1451 automatically monitors the current sink voltage for two or more shorted LEDs. To prevent thermal shutdown, the shorted LED string is disabled while the remaining strings continue to operate. The shorted LED string remains disabled until a power cycle or  $\overline{SHDN}$  cycle. The open drain  $\overline{FAULT}$  output is

driven low to indicate thermal shutdown and shorted LED condition(s). The  $\overline{FAULT}$  output is latched low during shorted LED fault, and is reset after a power cycle,  $\overline{SHDN}$  cycle or thermal shutdown. To prevent damage, the backlight can be shutdown based on the  $\overline{FAULT}$  output.

### **OVP Protection**

Under all conditions, the over-voltage protection circuitry prevents the switching node (SW) from exceeding the maximum operating voltage prior to disabling the current sink. Over-voltage protection (OVP) disables boost switching while maintaining the programmed LED current. Boost switching is re-enabled when OVP hysteresis is satisfied.

### **Thermal Protection for Over-Current and Short-Circuit**

The AAT1451 has a built-in thermal protection circuit that goes into shutdown when the die temperature rises above the thermal limit, as is the case during a LED short-circuit condition. Integrated over-current limit protection is provided. Over-current prevents inductor saturation and any resulting damage to the switching device occurring during an overload fault condition.

**Four-LED Strings, High Efficiency White LED Driver for LCD Backlighting****Application Information****LED Selection**

The AAT1451 is specifically intended for driving white LEDs. However, the device design will allow the AAT1451 to drive most types of LEDs with forward voltage specifications typically ranging from 2.2V to 4.7V depending upon supply voltage. LED applications may include mixed arrangements for display backlighting, keypad display, and any other application that needs a constant current sink generated from a varying input voltage. Since the FB1 to FB4 constant current sinks are matched within 2% with negligible supply voltage dependence, the constant current channels will be matched regardless of the specific LED forward voltage ( $V_F$ ) levels. The low dropout current sinks in the AAT1451 maximize performance and make it capable of driving LEDs with high forward voltages.

**Shutdown**

To activate the shutdown operation, the  $\overline{\text{SHDN}}$  input for the AAT1451 should be strobed low. In this case, the AAT1451 typically draws less than 40 $\mu$ A from the input.

**Inductor Selection**

The white LED boost (step-up) converter is designed to operate with a 4.7 $\mu$ H inductor for all input and output voltage combinations. The inductor saturation current rating should be greater than the NMOS current limit.

$$D_{\text{MAX}} = \frac{V_{\text{OUT}} + V_D - V_{\text{IN(MIN)}}}{V_{\text{OUT}} + V_D}$$

Where:

$V_{\text{OUT}}$  is the boost converter output voltage;  
 $V_D$  is the forward voltage of Schottky diode;  
 $V_{\text{IN(MIN)}}$  is the minimum input voltage.

The output inductor (L) is selected to avoid saturation at minimum input voltage, maximum output load conditions. Peak current may be calculated from the following equation, again assuming continuous conduction mode. Worst-case peak current occurs at minimum input voltage (maximum duty cycle) and maximum load. Switching frequency is estimated at 600kHz with a 4.7 $\mu$ H inductor.

$$I_{\text{PEAK}} = \frac{I_{\text{OUT}}}{1 - D_{\text{MAX}}} + \frac{D_{\text{MAX}} \cdot V_{\text{IN(MIN)}}}{2 \cdot F_S \cdot L}$$

**Compensation Component Selection**

The AAT1451 Main Boost architecture uses peak current mode control to eliminate the double pole effect of the output L&C filter and simplifies the compensation loop design. The current mode control architecture simplifies the transfer function of the control loop to be a one-pole, one left plane zero and one right half plane (RHP) system in frequency domain. The dominant pole can be calculated by:

$$f_P = \frac{1}{2\pi \cdot R_O \cdot C_{\text{OUT}}}$$

The ESR zero of the output capacitor can be calculated by:

$$f_{Z_{\text{ESR}}} = \frac{1}{2\pi \cdot R_{\text{ESR}} \cdot C_{\text{OUT}}}$$

Where:

$C_{\text{OUT}}$  is the output filter capacitor;  
 $R_O$  is the equivalent load resistor value;  
 $R_{\text{ESR}}$  is the equivalent series resistance of the output capacitor.

The right half plane (RHP) zero can be determined by:

$$f_{Z_{\text{ESR}}} = \frac{V_{\text{IN}}^2}{2\pi \cdot L_1 \cdot I_{\text{OUT}} \cdot V_{\text{OUT}}}$$

It is recommended to design the bandwidth to one decade lower than the frequency of RHP zero to guarantee the loop stability. A series capacitor and resistor network ( $R_{\text{COMP}}$  and  $C_{\text{COMP}}$ ) connected to the COMP pin sets the pole and zero which are given by:

$$f_{P_{\text{COM}}} = \frac{1}{2\pi \cdot R_{\text{EA}} \cdot C_{\text{COMP}}}$$

$$f_{Z_{\text{COM}}} = \frac{1}{2\pi \cdot R_{\text{COMP}} \cdot C_{\text{COMP}}}$$

Where:

$C_{\text{COMP}}$  is the compensation capacitor;  
 $R_{\text{COMP}}$  is the compensation resistor;  
 $R_{\text{EA}}$  is the output resistance of the error amplifier (M $\Omega$ ).

A 15nF capacitor and a 20k $\Omega$  resistor in series are chosen for optimum phase margin and fast transient response.

**Four-LED Strings, High Efficiency White LED Driver for LCD Backlighting****Capacitor Selection**

Careful selection of the external capacitor  $C_{IN}$  is important because it will affect turn-on time and transient performance. Optimum performance will be obtained when low equivalent series resistance (ESR) ceramic capacitor is used; in general, low ESR may be defined as less than  $100\text{m}\Omega$ . A value of  $2.2\mu\text{F}$  for the input capacitor is a good starting point when choosing a capacitor. If the constant current sinks are only programmed for light current levels then the input capacitor size may be decreased.

**Capacitor Characteristics**

Ceramic composition capacitor is highly recommended over all other types of capacitors for use with the AAT1451. Ceramic capacitors offer many advantages over their tantalum and aluminum electrolytic counterparts. A ceramic capacitor typically has very low ESR, is lower cost, has a smaller PCB footprint, and is non-polarized. Since ceramic capacitors are non-polarized, they are not prone to incorrect connection damage.

**Equivalent Series Resistance**

ESR is an important characteristic to consider when selecting a capacitor. ESR is a resistance internal to a capacitor that is caused by the leads, internal connections, size or area, material composition, and ambient temperature. Capacitor ESR is typically measured in milliohms for ceramic capacitors and can range to more than several ohms for tantalum or aluminum electrolytic capacitors.

**Ceramic Capacitor Materials**

Ceramic capacitor less than  $0.1\mu\text{F}$  are typically made from NPO or C0G materials. NPO and C0G materials generally have tight tolerance and are very stable over temperature. Larger capacitor values are usually composed of X7R, X5R, Z5U or Y5V dielectric materials. Large ceramic capacitors (i.e. larger than  $4.7\mu\text{F}$ ) are often available in low cost Y5V and Z5U dielectrics, but capacitors larger than  $4.7\mu\text{F}$  are not typically required for

AAT1451 applications.

Capacitor area is another contributor to ESR. Capacitors that are physically large will have a lower ESR when compared to an equivalent material smaller capacitor. These larger devices can improve circuit transient response when compared to an equal value capacitor in a smaller package size.

**PCB Layout Considerations**

When designing a PCB for the AAT1451, the key requirements are:

1. Place the input and output decoupling capacitors  $C_{IN}$  and  $C_{OUT}$  as close to the chip as possible to reduce switching noise and output ripple.
2. Place the bypass capacitor  $C_{VDD}$  as close to the chip as possible.
3. Keep the power traces (GND, SW, and VIN) short, direct, and wide to allow large current flow. Place sufficient multiple-layer pads when needed to change the trace layer.
4. Connect the output capacitor  $C_{OUT}$ , output inductor L1 and Schottky diode DS1 as close as possible. Use connections as short as possible for L1 to the SW pins and place no signal lines under the inductor.
5. Place the peripheral components like  $R_{COMP}$ ,  $C_{COMP}$ ,  $R_{SET}$  and  $R_{FS}$  as close to the chip as possible.

**Evaluation Board User Interface**

The user interface for the AAT1451 evaluation board is provided by three buttons and two connection terminals. The board is operated by supplying external power and pressing individual buttons. Table 4 indicates the function of each button or button combination. To power-on the evaluation board, connect a power supply or battery to both the VIN (with 5 to 26V) and the VCC (with 2.2 to 5V) terminals.

A red LED indicates that VCC power is applied which is necessary to enable the AAT1451. Once one button is pressed, the green LED will flash once to indicate that the related action is processed.

## Four-LED Strings, High Efficiency White LED Driver for LCD Backlighting

### User Interface Functionality

Button(s) Pushed	Description
UP	[Push/Release once] Channels FB1 to FB4 are turned on with 1mA per channel. With every push/release the current is increased according to Table 3.
DOWN	[Push/Release once] Channels FB1 to FB4 are turned on with 22mA per channel. With every push/release the current is decreased according to Table 3.
CYCLE	[Push/Release once] Auto cycling up and down.

Table 4: AAT1451 Evaluation Board User Interface.

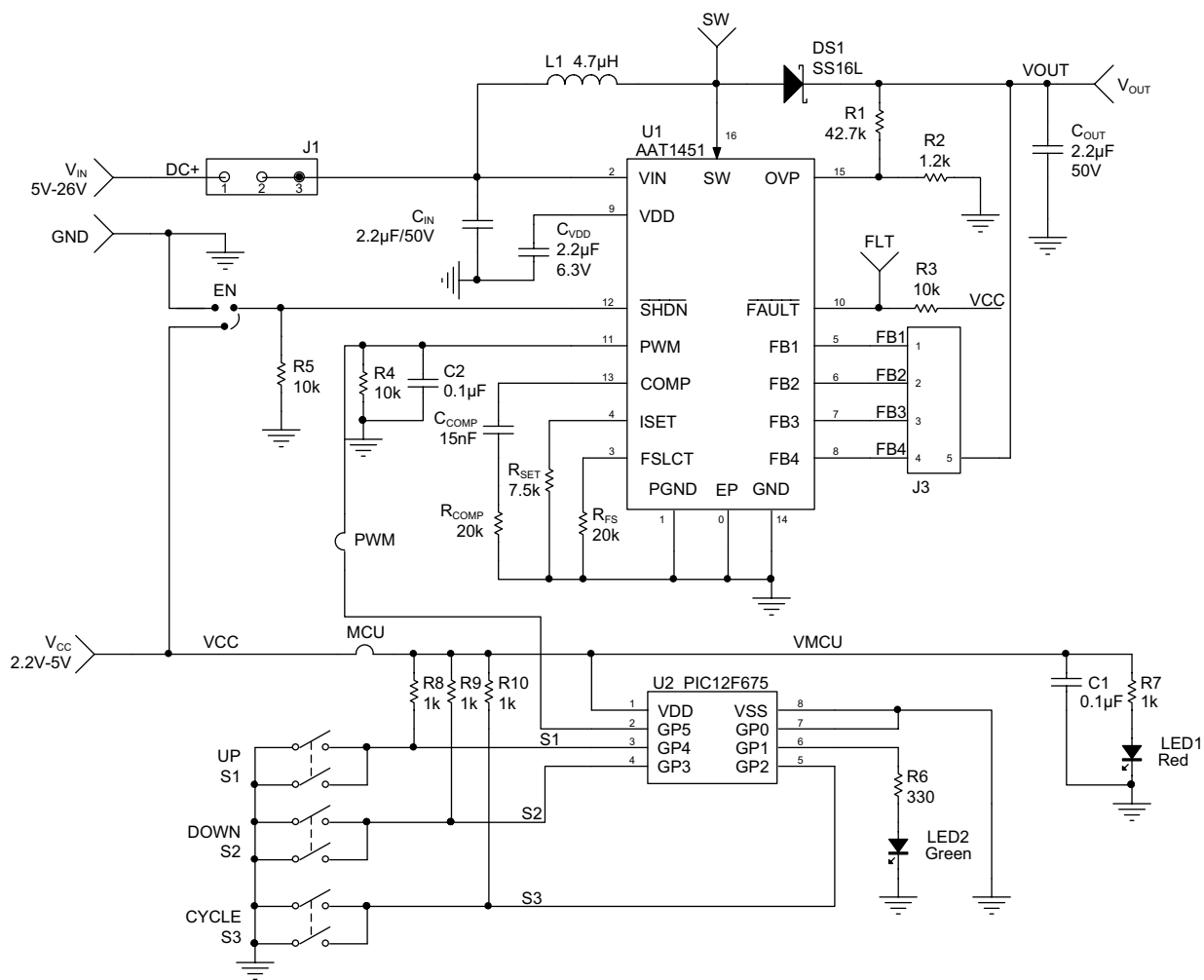
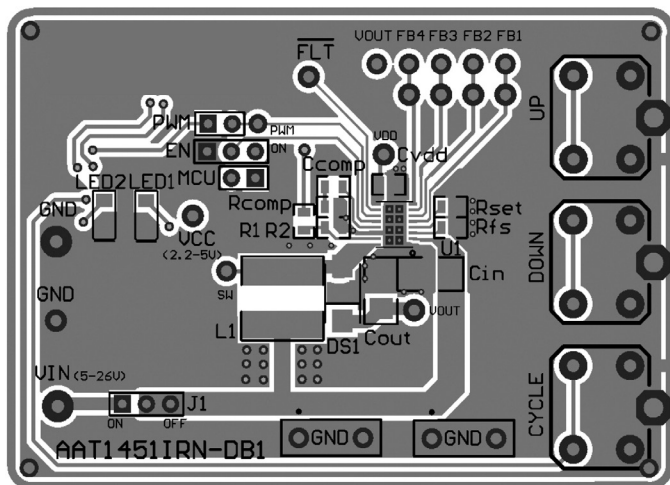

Figure 5: AAT1451 Evaluation Board Schematic.



# AAT1451

## Four-LED Strings, High Efficiency White LED Driver for LCD Backlighting



a: Top Side

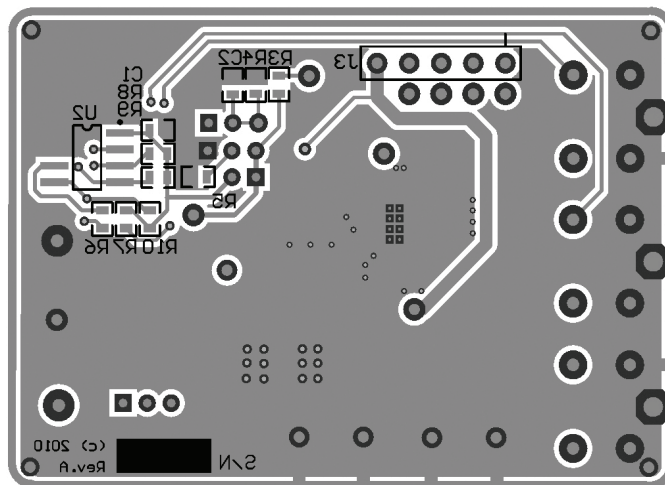

b: Bottom Side

Figure 6: AAT1451 Evaluation Board Layout.

Component	Part Number	Description	Manufacturer
U1	AAT1451	High Efficiency White Backlight LED Driver	Skyworks
U2	PIC12F675	8-bit CMOS, FLASH-based $\mu$ C; 8-pin PDIP package	Microchip
S1 - S3	PTS645TL50	Switch Tact, SPST, 5mm	ITT Industries
R <sub>COMP</sub> , R <sub>FS</sub>	Chip Resistor	20k $\Omega$ , 1%, 1/4W; 0603	Vishay
R <sub>SET</sub>	Chip Resistor	7.5k $\Omega$ , 1%, 1/4W; 0603	Vishay
R1	Chip Resistor	42.7k $\Omega$ , 1%, 1/4W; 0603	Vishay
R2	Chip Resistor	1.2k $\Omega$ , 1%, 1/4W; 0603	Vishay
R3, R4, R5	Chip Resistor	10k $\Omega$ , 1%, 1/4W; 0603	Vishay
R6	Chip Resistor	330 $\Omega$ , 1%, 1/4W; 0603	Vishay
R7, R8, R9, R10	Chip Resistor	1k $\Omega$ , 1%, 1/4W; 0603	Vishay
C <sub>IN</sub> , C <sub>OUT</sub>	GRM31CR71H225KA88	2.2 $\mu$ F, 50V, X7R, 1206	Murata
C <sub>VDD</sub>	GCM188R70J225KE22	2.2 $\mu$ F, 6.3V, X7R, 0603	Murata
C <sub>COMP</sub>	GRM188R71H153KA01	15nF, 50V, X7R, 0603	Murata
C1, C2	GRM188R71H104KA93	0.1 $\mu$ F, 50V, X7R, 0603	Murata
L1	SD53-4R7-R	4.7 $\mu$ H, 45m $\Omega$ , 2.01A, 20%	Coiltronics
DS1	SS16L	1.0A, 60V Surface Mount Schottky Barrier Rectifier	TSC
LED1	CMD15-21SRC/TR8	Red LED; 1206	Chicago Miniature Lamp
LED2	CMD15-21UGC/TR8	Green LED; 1206	Chicago Miniature Lamp

Table 5: AAT1451 Evaluation Board BOM List.

Manufacturer	Part Number	L ( $\mu$ H)	Max DCR (m $\Omega$ )	Saturation Current (A)	Size WxLxH (mm)
Murata	LQH6PPN4R7M43	4.7	20	3.2	6.0x6.0x4.3
	LQH6PPN6R8M43	6.8	28	2.8	
Coiltronics	SD53-4R7-R	4.7	45	2.01	5.2x5.2x3.0
	SD53-6R8-R	6.8	68	1.65	

Table 6: Surface Mount Inductors.

**Four-LED Strings, High Efficiency White LED Driver for LCD Backlighting**

Manufacturer	Part Number	Value ( $\mu$ F)	Voltage (V)	Tolerance	Temp. Co.	Case
Murata	GCM188R70J225KE22	2.2	6.3	10%	X7R	0603
	GRM188R71H153KA01	0.015	50	10%	X7R	0603
	GRM188R71H104KA93	0.1	50	10%	X7R	0603
	GRM31CR71H225KA88	2.2	50	10%	X7R	1206
AVX	06036C225KAT	2.2	6.3	10%	X7R	0603
	06035C163KAT	0.015	50	10%	X7R	0603
	06035C104KAT	0.1	50	10%	X7R	0603
	12065C225KAT	2.2	50	10%	X7R	1206
KEMET	C0603C225K9RAC	2.2	6.3	10%	X7R	0603
	C0603C153K5RAC	0.015	50	10%	X7R	0603
	C0603C104K5RAC	0.1	50	10%	X7R	0603
	C1206C225K5RAC	2.2	50	10%	X7R	1206

**Table 7: Surface Mount Capacitors.**

# AAT1451

## Four-LED Strings, High Efficiency White LED Driver for LCD Backlighting

### Single Li-ion Cell Powered Application:

Figure 7 demonstrates a backlight solution for single cell Li-ion battery powered application using the AAT1451 to drive the WLEDs and the AAT3110 regulated charge pump to supply the internal regulator of AAT1451. The AAT1451

plus AAT3110 solution is adopted to drive 6 series-4 parallel (6S4P) to 8 series-4 parallel (8S4P) typical of 13" and smaller sized displays. Figure 8 shows the efficiency.

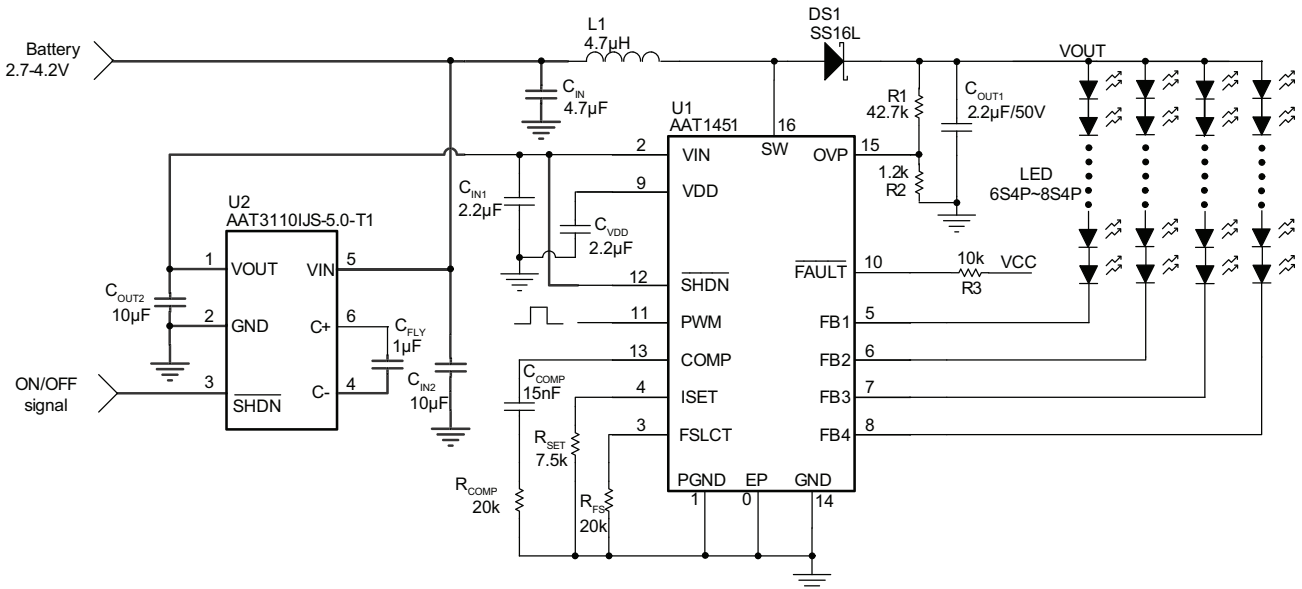

Figure 7: Schematic of AAT1451 plus AAT3110

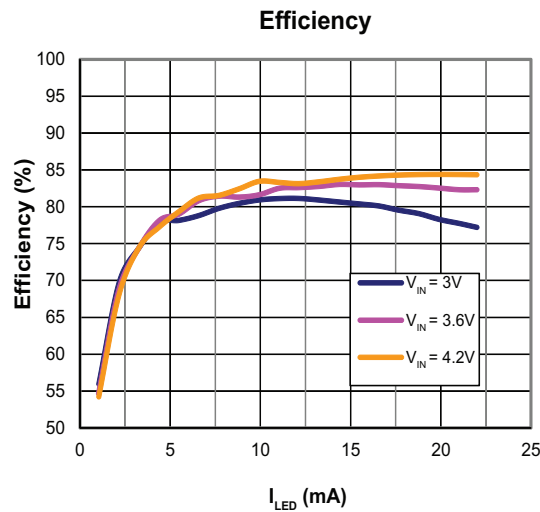

Figure 8: Efficiency vs I<sub>LED</sub> for driving 8series - 4parallel (8S4P) LEDs

**Four-LED Strings, High Efficiency White LED Driver for LCD Backlighting****Ordering Information**

Package	Part Marking <sup>1</sup>	Part Number (Tape and Reel) <sup>2</sup>
TDFN34-16	N5XY	<b>AAT1451IRN-T1</b>



Skyworks Green™ products are compliant with all applicable legislation and are halogen-free.

For additional information, refer to *Skyworks Definition of Green™*, document number SQ04-0074.

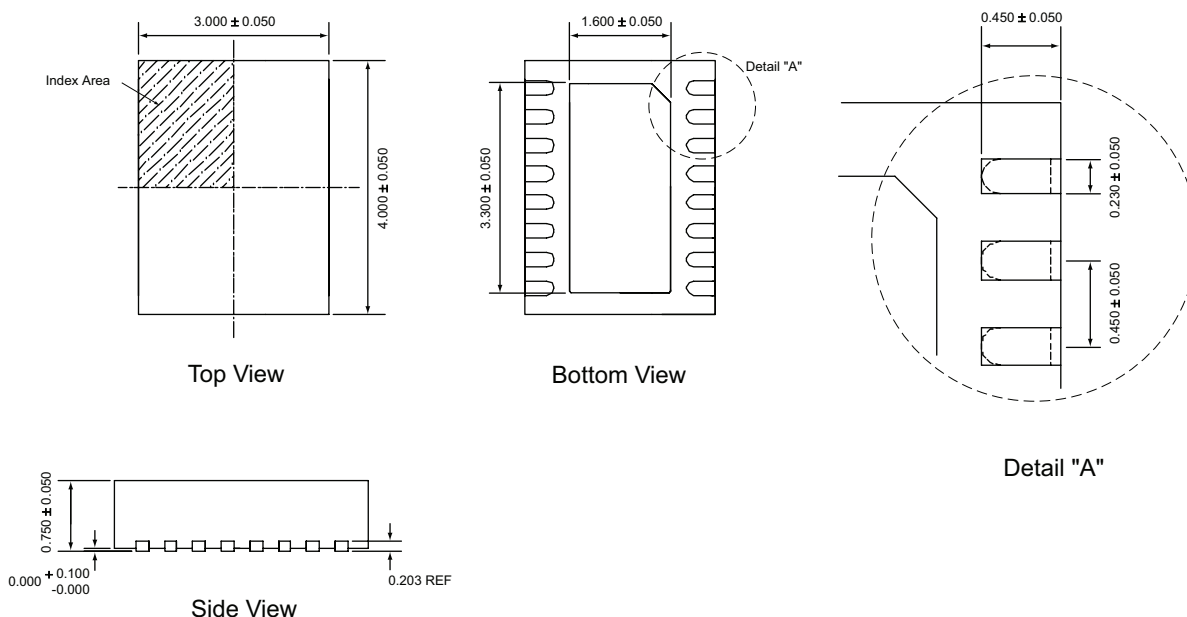
**Package Information****TDFN34-16**

All dimensions in millimeters.

1. XYY = assembly and date code.
2. Sample stock is generally held on part numbers listed in **BOLD**.

Copyright © 2012 Skyworks Solutions, Inc. All Rights Reserved.

Information in this document is provided in connection with Skyworks Solutions, Inc. ("Skyworks") products or services. These materials, including the information contained herein, are provided by Skyworks as a service to its customers and may be used for informational purposes only by the customer. Skyworks assumes no responsibility for errors or omissions in these materials or the information contained herein. Skyworks may change its documentation, products, services, specifications or product descriptions at any time, without notice. Skyworks makes no commitment to update the materials or information and shall have no responsibility whatsoever for conflicts, incompatibilities, or other difficulties arising from any future changes.

No license, whether express, implied, by estoppel or otherwise, is granted to any intellectual property rights by this document. Skyworks assumes no liability for any materials, products or information provided hereunder, including the sale, distribution, reproduction or use of Skyworks products, information or materials, except as may be provided in Skyworks Terms and Conditions of Sale.

THE MATERIALS, PRODUCTS AND INFORMATION ARE PROVIDED "AS IS" WITHOUT WARRANTY OF ANY KIND, WHETHER EXPRESS, IMPLIED, STATUTORY, OR OTHERWISE, INCLUDING FITNESS FOR A PARTICULAR PURPOSE OR USE, MERCHANTABILITY, PERFORMANCE, QUALITY OR NON-INFRINGEMENT OF ANY INTELLECTUAL PROPERTY RIGHT; ALL SUCH WARRANTIES ARE HEREBY EXPRESSLY DISCLAIMED. SKYWORKS DOES NOT WARRANT THE ACCURACY OR COMPLETENESS OF THE INFORMATION, TEXT, GRAPHICS OR OTHER ITEMS CONTAINED WITHIN THESE MATERIALS. SKYWORKS SHALL NOT BE LIABLE FOR ANY DAMAGES, INCLUDING BUT NOT LIMITED TO ANY SPECIAL, INDIRECT, INCIDENTAL, STATUTORY, OR CONSEQUENTIAL DAMAGES, INCLUDING WITHOUT LIMITATION, LOST REVENUES OR LOST PROFITS THAT MAY RESULT FROM THE USE OF THE MATERIALS OR INFORMATION, WHETHER OR NOT THE RECIPIENT OF MATERIALS HAS BEEN ADVISED OF THE POSSIBILITY OF SUCH DAMAGE.

Skyworks products are not intended for use in medical, lifesaving or life-sustaining applications, or other equipment in which the failure of the Skyworks products could lead to personal injury, death, physical or environmental damage. Skyworks customers using or selling Skyworks products for use in such applications do so at their own risk and agree to fully indemnify Skyworks for any damages resulting from such improper use or sale.

Customers are responsible for their products and applications using Skyworks products, which may deviate from published specifications as a result of design defects, errors, or operation of products outside of published parameters or design specifications. Customers should include design and operating safeguards to minimize these and other risks. Skyworks assumes no liability for applications assistance, customer product design, or damage to any equipment resulting from the use of Skyworks products outside of stated published specifications or parameters.

Skyworks, the Skyworks symbol, and "Breakthrough Simplicity" are trademarks or registered trademarks of Skyworks Solutions, Inc., in the United States and other countries. Third-party brands and names are for identification purposes only, and are the property of their respective owners. Additional information, including relevant terms and conditions, posted at [www.skyworksinc.com](http://www.skyworksinc.com), are incorporated by reference.