

Customer Information Sheet

DRAWING No.: S1901-XXR

SHEET 2 OF 2

IF IN DOUBT - ASK

(C)

NOT TO SCALE

THIRD ANGLE PROJECTION

ALL DIMENSIONS IN mm

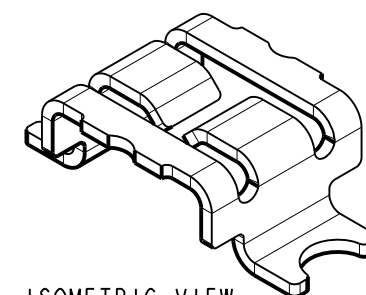
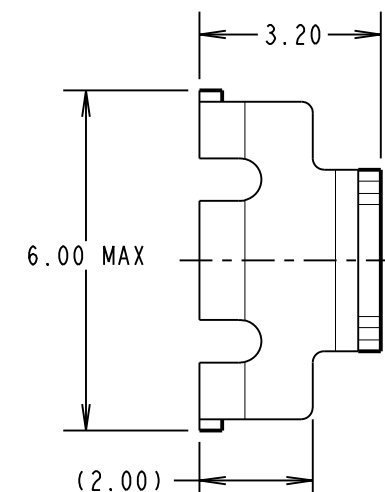
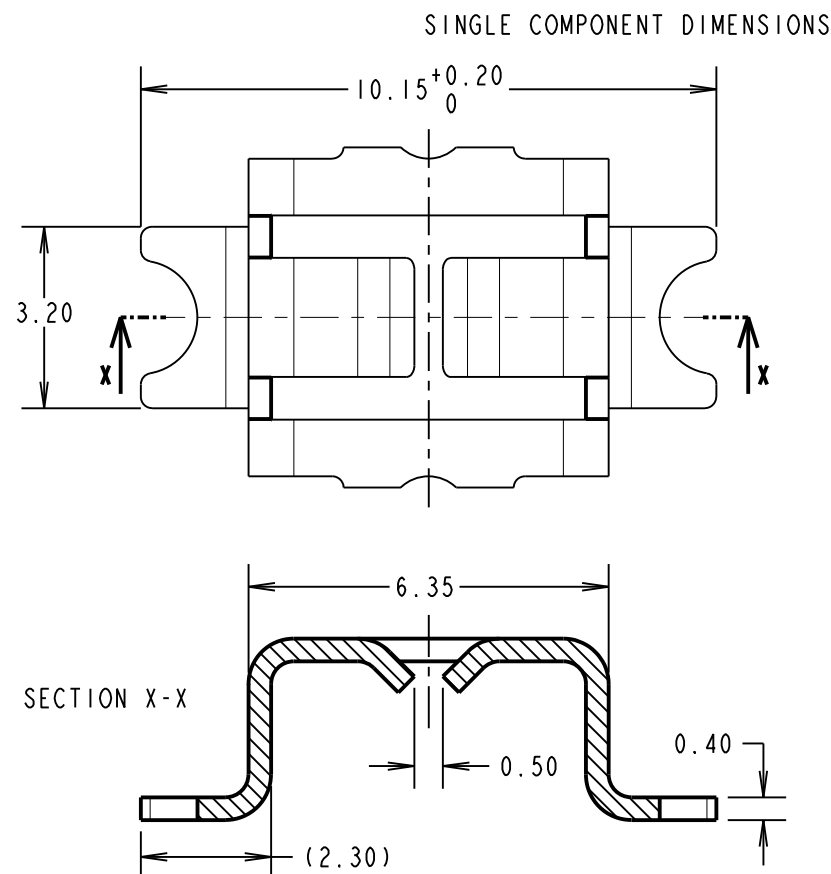
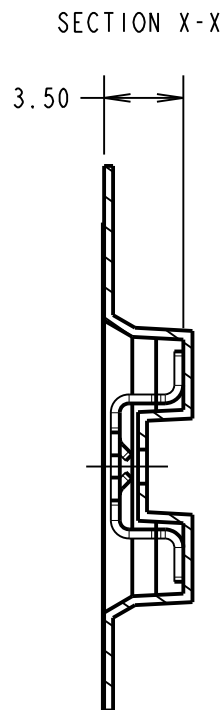
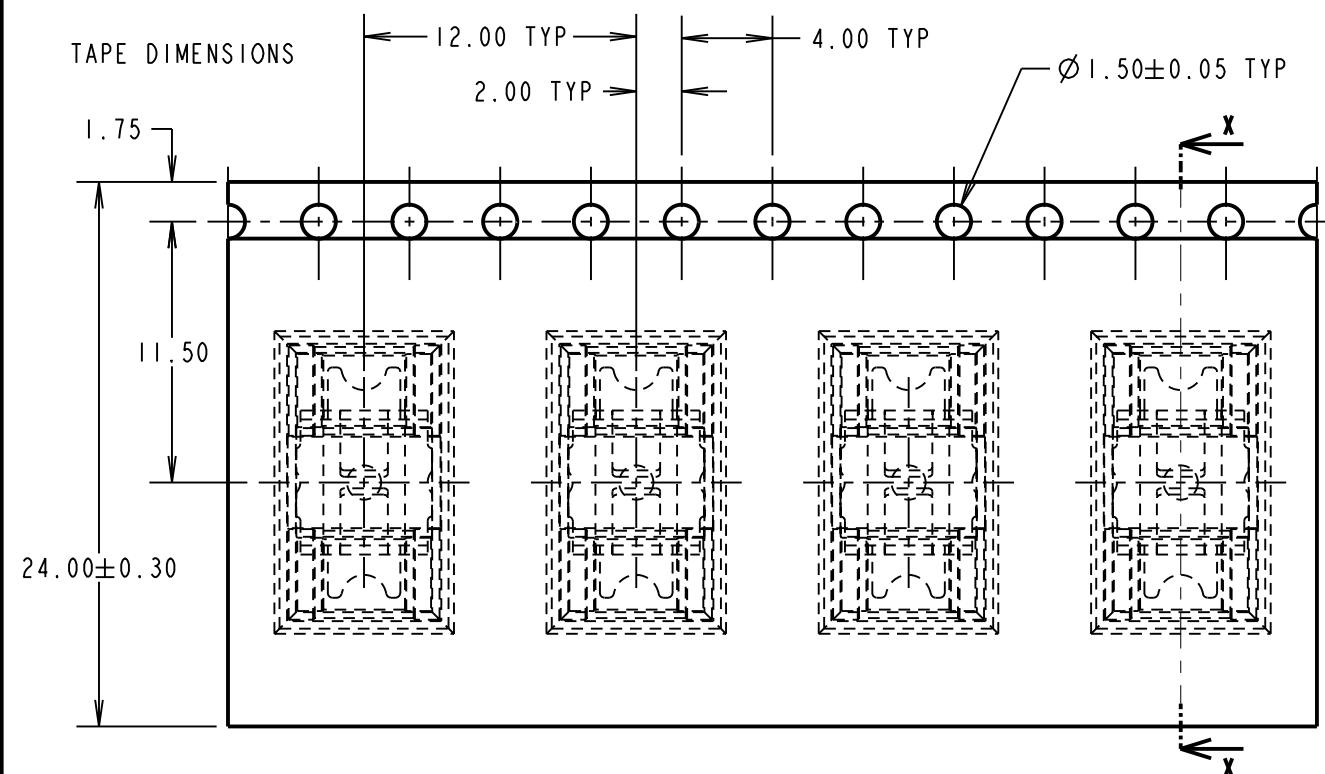

ISOMETRIC VIEW OF SINGLE COMPONENT

ORDER CODE	FINISH
S1901-06R	TIN/LEAD
S1901-46R	100% TIN

REELING DIRECTION

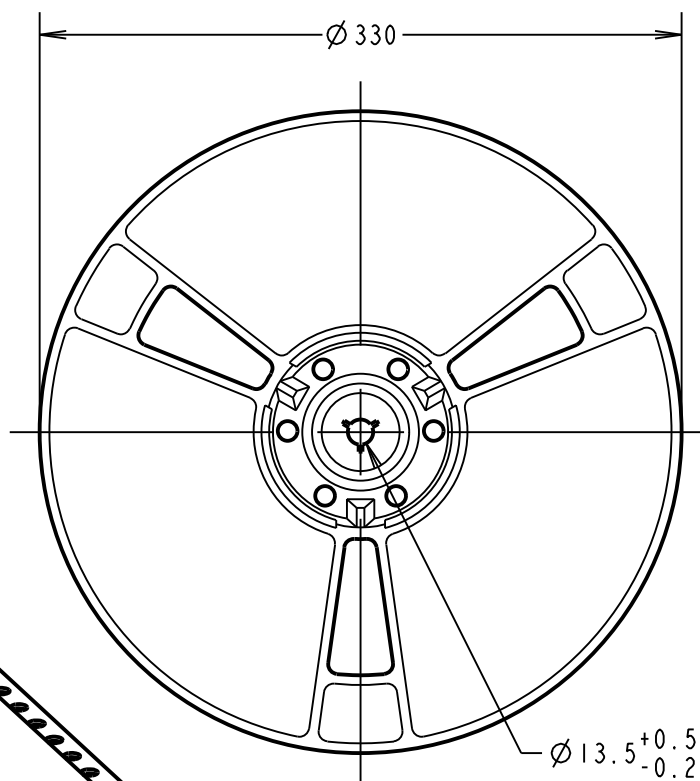
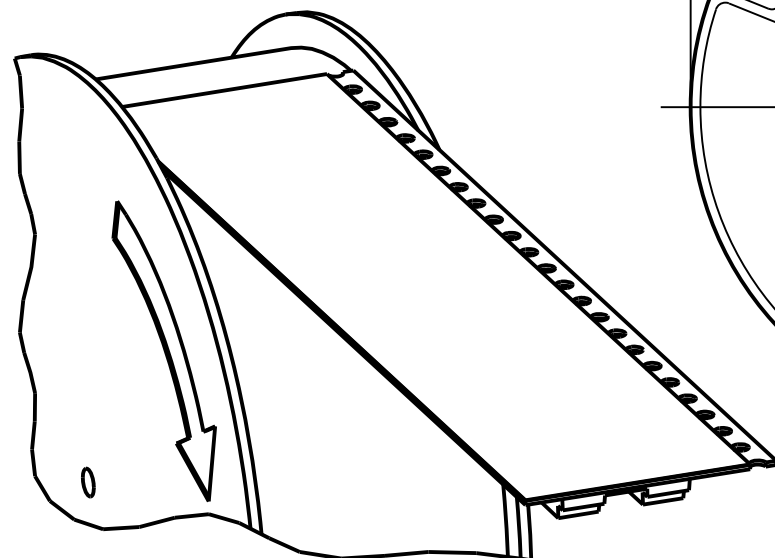

REEL DIMENSIONS

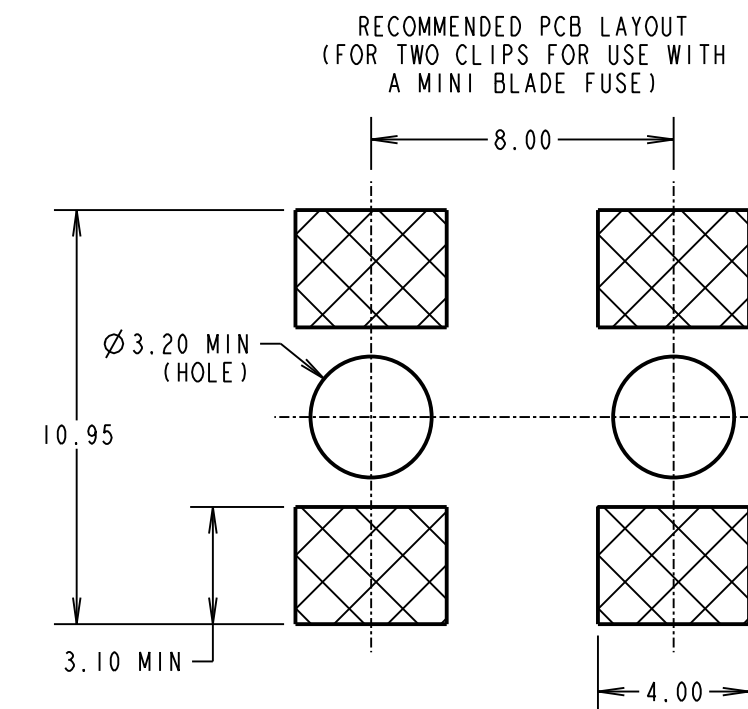
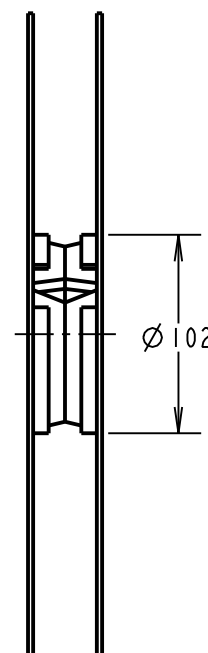

- NOTES:
1. QUANTITY PER REEL = 1,500.
 2. FOR LOOSE COMPONENTS, SEE S1901-XX.
 3. THIS PRODUCT IS TAPED AND REELED IN ACCORDANCE WITH EIA-481-2 (ELECTRONIC INDUSTRIES ASSOCIATION).
 4. SUITABLE FOR USE WITH AUTOMOTIVE MINI BLADE FUSES, OR OTHER 2.8 x 0.8mm TERMINALS.

HARWIN

HARWIN USA TEL: 603 893 5376 FAX: 603 893 5396 mis@harwin.com	HARWIN Europe (UK) TEL: 023 9231 4545 FAX: 023 9231 4590 mis@harwin.co.uk	HARWIN Asia TEL: +65 6 779 4909 FAX: +65 6 779 3868 mis@harwin.com.sg
--	--	--

THIS DRAWING AND ANY INFORMATION OR DESCRIPTIVE MATTER SET OUT HEREON ARE CONFIDENTIAL AND COPYRIGHT PROPERTY OF THE HARWIN GROUP AND MUST NOT BE DISCLOSED, LOANED, COPIED OR USED FOR MANUFACTURING, TENDERING OR FOR ANY OTHER PURPOSE WITHOUT THEIR WRITTEN PERMISSION.

TOLERANCES
X. = ±1mm
X.X = ±0.25mm
X.XX = ±0.10mm
X.XXX = ±0.01mm
ANGLES = ±5°
UNLESS STATED

MATERIAL:
BRASS CW508L H150
BS EN 1652: 1998
FINISH: SEE TABLE
S/AREA: mm²

TITLE:
SMT MINI BLADE FUSE CLIP
(TAPE AND REELED)

DRAWING NUMBER:
S1901-XXR
SHT 2 OF 2

CP	3	21.05.10	10811
NAME	ISS.	DATE	C/NOTE
APPROVED: C. PENROSE			
CHECKED: R. ADDE			
DRAWN: W. J. BOURNE			
CUSTOMER REF.:			
ASSEMBLY DRG:			