

Demonstration System EPC9507 Quick Start Guide

*ZVS Class-D Wireless Power Amplifier
Demo Board using EPC2007C / EPC2038*

Revision 3.2



DESCRIPTION

The EPC9507 is a high efficiency, Zero Voltage Switching (ZVS), Class-D Wireless Power amplifier demonstration board operating at 6.78 MHz (Lowest ISM band). The purpose of this demonstration system is to simplify the evaluation process of wireless power technology using eGaN® FETs by including all the critical components on a single board that can be easily connected into an existing system.

The amplifier board features the EPC2007C and EPC2038 enhancement mode field effect transistors (FET) in an optional half-bridge topology (single ended configuration) or default full-bridge topology (differential configuration), and includes the gate driver/s and oscillator that ensures operation of the system at 6.78 MHz. This revision of the wireless demonstration amplifier includes a synchronous bootstrap FET supply for the upper FETs of the ZVS Class-D amplifier that eliminates the reverse recovery losses of the gate driver's internal bootstrap diode that dissipates energy in the upper FET. This circuit has been implemented using the new EPC2038 eGaN FET specifically designed for this function. To learn more about the synchronous bootstrap supply please refer to the following [1, 2, 3]. The EPC9507 amplifier board can also be operated using an external oscillator or by using the included ultra low power oscillator.

- [1] [Wireless Power Handbook](#)
- [2] [Performance Comparison for A4WP Class-3 Wireless Power Compliance between eGaN FET and MOSFET in a ZVS Class-D Amplifier](#)
- [3] [EPC2038 datasheet](#)

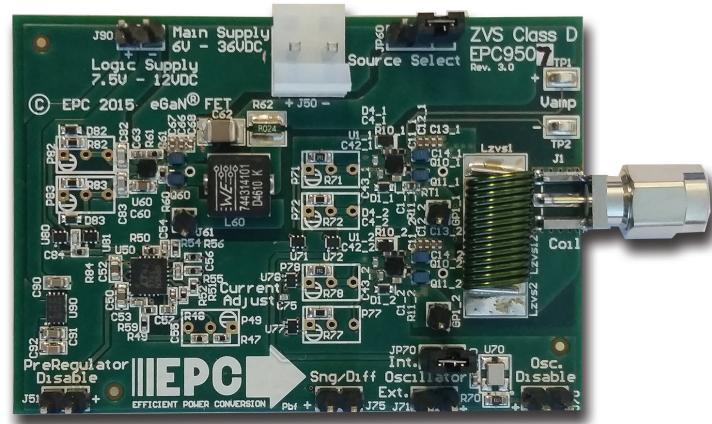

EPC9507 Amplifier Board

This revision can operate in either Single ended or Differential mode by changing a jumper setting. This allows for high efficiency operation with load impedance ranges that allow for single ended operation.

Finally, the timing adjust circuits for the ZVS Class-D amplifiers have been separated to further ensure highest possible efficiency setting and includes separate ZVS tank circuits.

The amplifier board is equipped with a pre-regulator that limits the DC current of the supply to the amplifier. As the amplifier draws more current, which can be due to the absence of a device coil, the pre-regulator will reduce the voltage being supplied to the amplifier that will ensure a safe operating point. The pre-regulator also monitors the temperature of the main amplifier FETs and will reduce current if the temperature exceeds 85°C. The pre-regulator can be bypassed to allow testing with custom control hardware. The board further allows easy access to critical measurement nodes that allow accurate power measurement instrumentation hookup. A simplified diagram of the amplifier board is given in Figure 1.

For more information on the EPC2007C or EPC2038 eGaN FET please refer to the datasheet available from EPC at www.epc-co.com. The data-sheet should be read in conjunction with this quick start guide.

Table 1: Performance Summary (TA = 25 °C) EPC9507

Symbol	Parameter	Conditions	Min	Max	Units
V _{DD}	Control Supply Input Range		7	12	V
V _{IN}	Bus Input Voltage Range – Pre-Regulator Mode		8	36	V
V _{IN}	Bus Input Voltage Range – Bypass Mode		0	80	V
V _{OUT}	Switch Node Output Voltage			V _{IN} - 2V	V
I _{OUT}	Switch Node Output Current (each)			6*	A
V _{extosc}	External Oscillator Input Threshold	Input 'Low'	-0.3	0.8	V
		Input 'High'	2.4	5	V
V _{Pre_Disable}	Pre-regulator Disable Voltage Range	Open drain/collector	-0.3	5.5	V
I _{Pre_Disable}	Pre-regulator Disable Current	Open Drain/Collector	-1	1	mA
V _{Osc_Disable}	Oscillator Disable Voltage Range	Open Drain/Collector	-0.3	5	V
I _{Osc_Disable}	Oscillator Disable Current	Open Drain/Collector	-25	25	mA

* Assumes inductive load, maximum current depends on die temperature – actual maximum current will be subject to switching frequency, bus voltage and thermals.

DESCRIPTION

The Amplifier Board (EPC9507)

Figure 1 shows a diagram of the EPC9507 ZVS Class-D amplifier with pre-regulator. The pre-regulator is set to a specified DC current limit (up to 1.5 A) by adjusting P49 and operates from 8 V through 36 V input. The output voltage of the pre-regulator is limited to approximately 2 V below the input voltage. The pre-regulator can be bypassed by moving the jumper (JP60) over from the right 2 pins to the left 2 pins. To measure the current the amplifier is drawing, an ammeter can be inserted in place of the jumper (JP60) in the location based on the operating mode (pre-regulator or bypass).

The amplifier comes with its own oscillator that is pre-programmed to 6.78 MHz ± 678 Hz. It can be disabled by placing a jumper into J70 or can be externally shutdown using an externally controlled open collector / drain transistor on the terminals of J70 (note which is the ground connection). The switch needs to be capable of sinking at least 25 mA. An external oscillator can be used instead of the internal oscillator when connected to J71 (note which is the ground connection) and the jumper (JP70) is moved from the right 2 pins to the left 2 pins.

The pre-regulator can also be disabled in the same manner as the oscillator using J51. The pre-regulator can be bypassed, to increase the operating voltage (with no current or thermal protection) to the amplifier or to use an external regulator, by moving the jumper JP60 from the right 2 pins to the left 2 pins. Jumper JP60 can also be used to connect an ammeter to measure the current drawn by the amplifier (make sure the ammeter connects to the pins that correspond to the mode of operation either bypass or pre-regulator).

Single Ended Operation Hardware implementation

The amplifier can be configured for single ended operation where only devices Q1 and Q2 are used. In this mode only L_{ZVS1} and C_{ZVS} are used to establish ZVS operation. If a permanent single ended configuration is required and Q11 and Q12 are populated, then the following changes need to be made to the board:

- 1) Remove R77 and R78 OR P77 and P78
- 2) Short out C42_2 and C43_2
- 3) Short the connection of JMP1 (back side of the board)
- 4) Remove L_{ZVS12} (if populated)
- 5) Add L_{ZVS2} (390 nH)
- 6) Check that C_{ZVS2} is populated, if not then install.
- 7) R71 and R72 may need to be adjusted for the new operating condition to achieve maximum efficiency (see section on ZVS timing adjustment).

ZVS Timing Adjustment

Setting the correct time to establish ZVS transitions is critical to achieving high efficiency with the EPC9507 amplifier. This can be done by selecting the values for R71, R72, R77, and R78 respectively. This procedure is best performed using potentiometers P71, P72, P77, and P78 installed that is used to determine the fixed resistor values. The procedure is the same for both single ended and differential mode of operation (as applicable per operating mode). The timing MUST initially be set WITHOUT the source coil connected to the amplifier. The timing diagrams are given in Figure 4 and should be referenced when following this procedure. Only perform these steps if changes have been made to the board as it is shipped preset.

The steps are:

1. Remove the jumper in JP60 and insert it into J51 to place the EPC9507 amplifier in bypass mode. With power off connect the main input power supply (+) bus to the center pin of JP60 (pin 2) and the ground of the main power to the ground (-) connection of J50 -V_{IN}.
2. With power off, connect the control input power supply bus to +V_{DD} (J90). Note the polarity of the supply connector.
3. Connect a LOW capacitance oscilloscope probe to the probe-hole J2 between the two eGaN FETs Q10_x and Q11_x and lean against the ground post as shown in Figure 3.
4. Turn on the control supply – make sure the supply is between 7V and 12 V range (7.5 V is recommended).
5. Turn on the main supply voltage to the required predominant operating value (such as 24 V but NEVER exceed the absolute maximum voltage of 36 V).
6. While observing the oscilloscope adjust P71 or P77 for the rising edge of the waveform so achieve the green waveform of figure 4. Repeat for the falling edge of the waveform by adjusting P72 or P78. Repeat for the other eGaN FET pair if using differential mode operation.
7. Check that the setting remains optimal with a source coil attached. In this case it is important that the source coil is TUNED to resonance WITH an applicable load. Theoretically the settings should remain unchanged. Adjust if necessary.
8. Replace the potentiometers with fixed value resistors. Configure the EPC9507 amplifier back to normal operation by removing the power connections to J50 and JP60, removing the jumper in J51 and inserting it back into JP60 (right 2 pins 2 & 3).

Determining Component Values for L_{ZVS}

The ZVS tank circuit is not operated at resonance, and only provides the necessary negative device current for self-commutation of the output voltage at turn off. The capacitance C_{ZVS} is chosen to have a very small ripple voltage component and is typically around 1 μF. The amplifier supply voltage, switch-node transition time will determine the value of inductance for L_{ZVSx} which needs to be sufficient to maintain ZVS operation over the DC device load resistance range and coupling between the device and source coil range and can be calculated using the following equation:

$$L_{ZVS} = \frac{\Delta t_{vt}}{8 \cdot f_{sw} \cdot C_{OSSQ}} \quad (1)$$

Where:

- Δt_{vt} = Voltage transition time [s]
- f_{sw} = Operating frequency [Hz]
- C_{OSSQ} = Charge equivalent device output capacitance [F].

Note that the amplifier supply voltage V_{AMP} is absent from the equation as it is accounted for by the voltage transition time. The charge equivalent capacitance can be determined using the following equation:

$$C_{OSSQ} = \frac{1}{V_{AMP}} \cdot \int_0^{V_{AMP}} C_{OSS}(v) \cdot dv \quad (2)$$

To add additional immunity margin for shifts in coil impedance, the value of L_{ZVS} can be decreased to increase the current at turn off of the devices (which will increase device losses). Typical voltage transition times range from 2 ns through 12 ns. For the differential case the voltage and charge (C_{OSSQ}) are doubled.

QUICK START PROCEDURE

The EPC9507 amplifier board is easy to set up and evaluate the performance of the eGaN FET in a wireless power transfer application.

The EPC9507 can be operated using any one of two alternative methods:

- a. Using the pre-regulator
- b. Bypassing the pre-regulator

a. Operation using the pre-regulator

The pre-regulator is used to supply power to the amplifier in this mode and will limit the DC current to the amplifier based on the setting. The pre-regulator also monitors the temperature of the amplifier and will limit the current in the event the temperature exceeds 85°C.

1. Make sure the entire system is fully assembled prior to making electrical connections and make sure jumper (JP60 is set to pre-regulator – right 2 pins).
2. With power off, connect the main input power supply bus to +V_{IN} (J50). Note the polarity of the supply connector.
3. With power off, connect the control input power supply bus to +V_{DD} (J90). Note the polarity of the supply connector.
4. Select and connect an applicable load resistance to the device board.
5. Make sure all instrumentation is connected to the system.
6. Turn on the control supply – make sure the supply is between 7 V and 12 V (7.5 V is recommended).
7. Turn on the main supply voltage to the required value (it is recommended to start at 8 V and do not exceed the absolute maximum voltage of 32 V).
8. Once operation has been confirmed, adjust the main supply voltage within the operating range and observe the output voltage, efficiency and other parameters on both the amplifier and device boards.
9. For shutdown, please follow steps in the reverse order. Start by reducing the main supply voltage to 0 V followed by steps 6 through 2.

b. Operation bypassing the pre-regulator

In this mode, the pre-regulator is bypassed and the main power is connected directly to the amplifier. This allows the amplifier to be operated using an external regulator or to test at higher voltages.

In this mode there is no current or thermal protection for the eGaN FETs.

1. Make sure the entire system is fully assembled prior to making electrical connections and remove the jumper JP60 and insert it into J51 to place the EPC9507 amplifier in bypass mode. Never connect the main power positive (+) to J50 when operating in bypass mode.
2. With power off, connect the main input power supply ground to the ground terminal of J50 (-) and the positive (+) to the center pin of JP60.
3. With power off, connect the control input power supply bus to +V_{DD} (J90). Note the polarity of the supply connector.
4. Select and connect an applicable load resistance to the device board.
5. Make sure all instrumentation is connected to the system.

6. Turn on the control supply – make sure the supply is between 7 V and 12 V range (7.5 V is recommended).
7. Turn on the main supply voltage to the required value (it is recommended to start at 2 V and do not exceed the absolute maximum voltage of 80 V).
8. Once operation has been confirmed, adjust the main supply voltage within the operating range and observe the output voltage, efficiency and other parameters on both the amplifier and device boards. See Pre-Cautions when operating in the bypass mode
9. For shutdown, please follow steps in the reverse order. Start by reducing the main supply voltage to 0 V followed by steps 6 through 2.

NOTE. When measuring the high frequency content switch-node (Source Coil Voltage), care must be taken to avoid long ground leads. An oscilloscope probe connection (preferred method) has been built into the board to simplify the measurement of the Source Coil Voltage (J2 and J3 as shown in Figure 3).

SWITCHING BETWEEN SINGLE-ENDED AND DIFFERENTIAL MODE OPERATION

The ZVS Class-D amplifier can be operated in either single-ended or differential mode operation by changing the jumper setting of J75. When inserted the amplifier operates in the single-ended mode. Using an external pull down with floating collector/ drain connection will have the same effect. The external transistor must be capable of sinking 25 mA and withstand at least 6 V.

THERMAL CONSIDERATIONS

The EPC9507 demonstration system showcases the EPC2007C and EPC2038 eGaN FETs in a wireless energy transfer application. Although the electrical performance surpasses that of traditional silicon devices, their relatively smaller size does magnify the thermal management requirements. The operator must observe the temperature of the gate driver and eGaN FETs to ensure that both are operating within the thermal limits as per the datasheets.

NOTE. The EPC9507 demonstration system has limited current and thermal protection only when operating off the Pre-Regulator. When bypassing the pre-regulator there is no current or thermal protection on board and care must be exercised not to over-current or over-temperature the devices. Wide coil coupling and load range variations can lead to increased losses in the devices.

Pre-Cautions

The EPC9507 demonstration system has no controller or enhanced protections systems and therefore should be operated with caution. Some specific precautions are:

1. Please contact EPC at info@epc-co.com should the tuning of the coil be required to change to suit specific conditions so that it can be correctly adjusted for use with the ZVS Class-D amplifier.
2. There is no heat-sink on the devices and during experimental evaluation it is possible present conditions to the amplifier that may cause the devices to overheat. Always check operating conditions and monitor the temperature of the EPC devices using an IR camera.

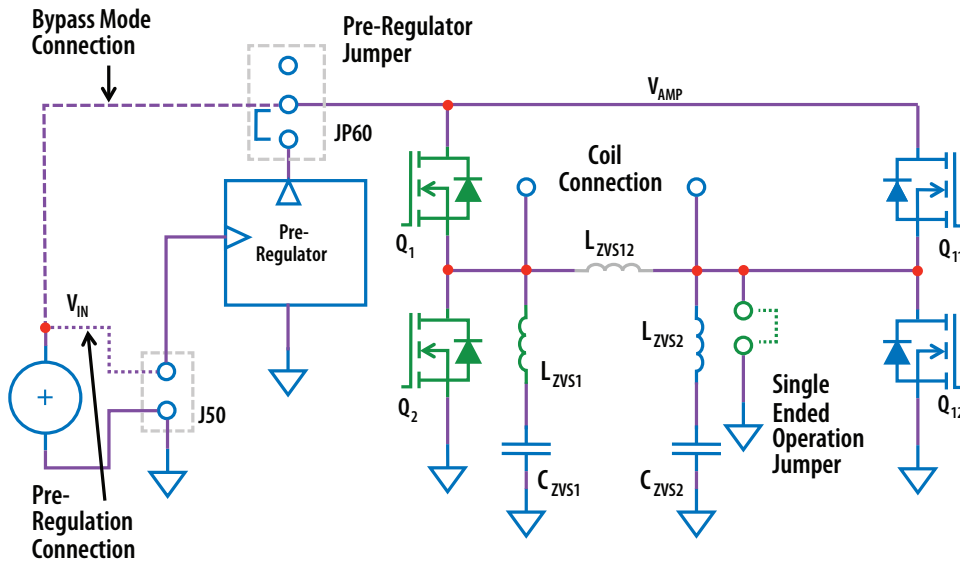

Figure 1: Diagram of EPC9507 Amplifier Board

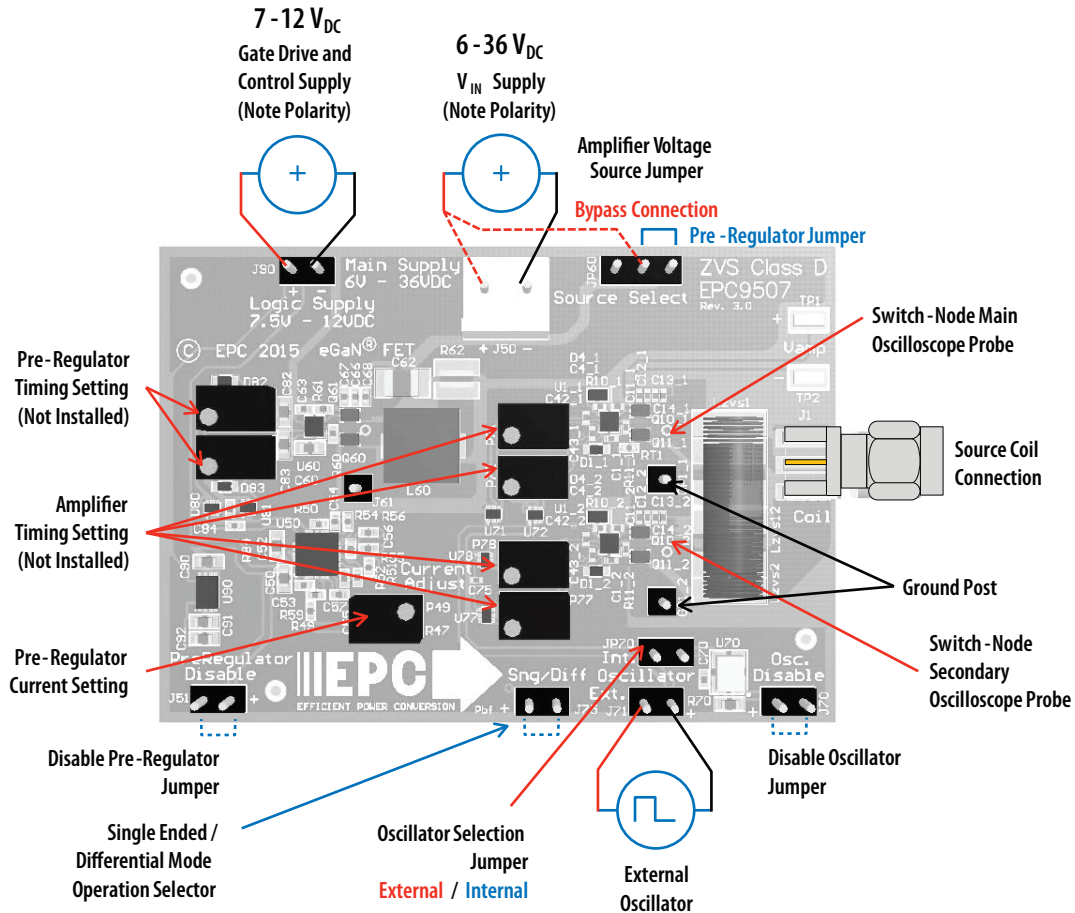

Figure 2: Proper Connection and Measurement Setup for the Amplifier Board

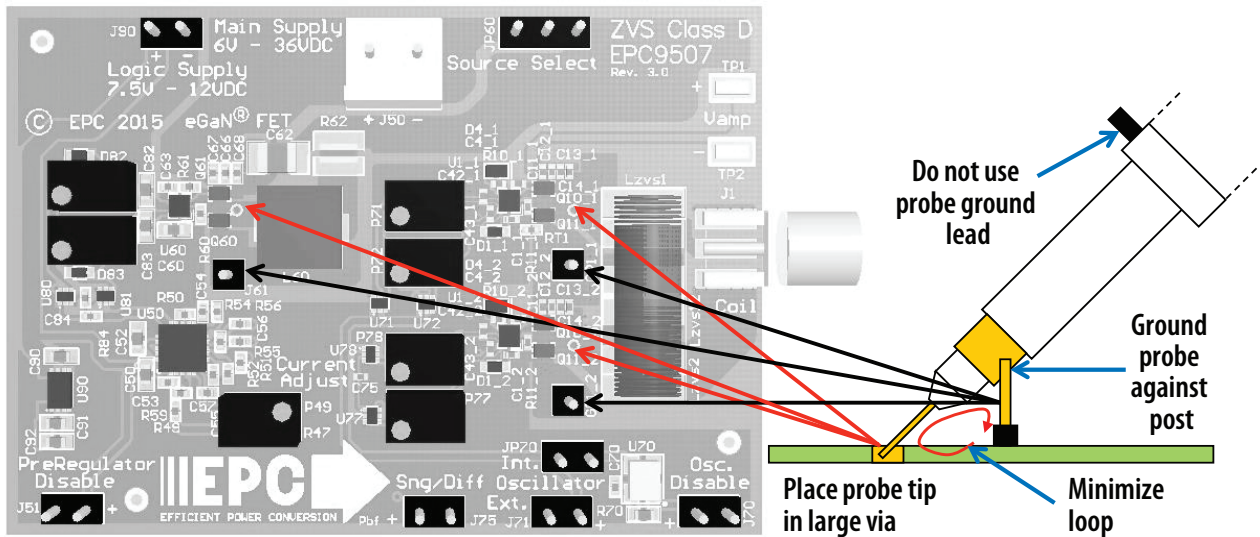

Figure 3: Proper Measurement of the Switch Nodes Using the Hole and Ground Post

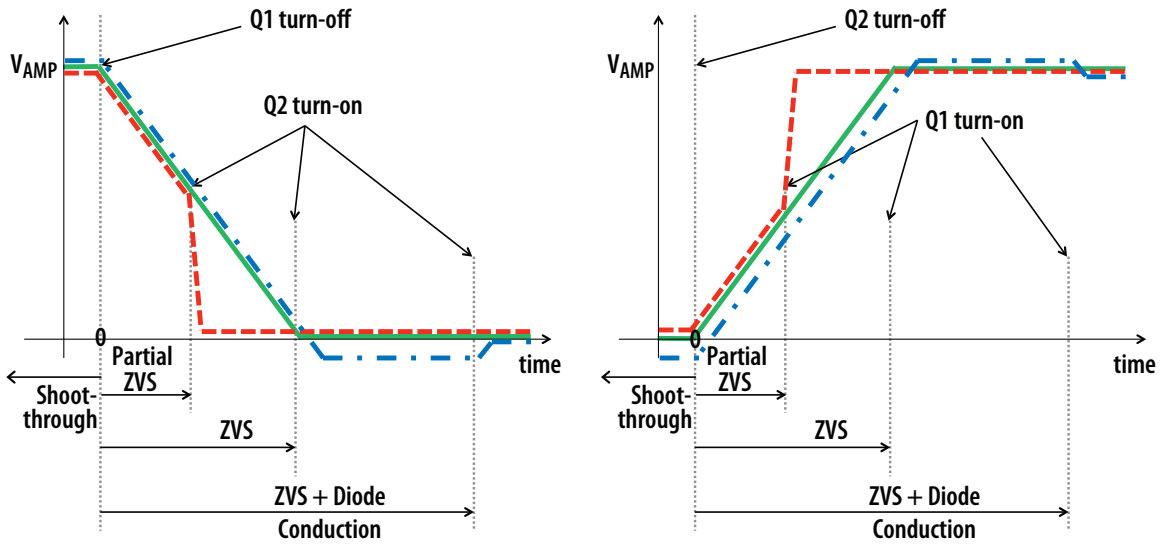

Figure 4: ZVS Timing Diagrams

Table 3: Bill of Materials - Amplifier Board					
Item	Qty	Reference	Part Description	Manufacturer	Part #
1	2	C1_1, C1_2	Capacitor, Ceramic, 4.7 μ F, \pm 20%, 10 V, X5R	Samsung	CL05A475MP5NRNC
2	2	C52, C60	Capacitor, Ceramic, 4.7 μ F, \pm 10%, 16 V, X5R	TDK	C1608X5R1C475K080AC
3	7	C15_1, C15_2, C16_1, C16_2, C62, C64, C65	Capacitor, Ceramic, 2.2 μ F, \pm 10%, 100 V, X7R	Taiyo Yuden	HMK325B7225KN-T
4	1	C50	Capacitor, Ceramic, 1 μ F, \pm 10%, 50 V, X7R	Taiyo Yuden	UMK107AB7105KA-T
5	2	Czvs1, Czvs2	Capacitor, Ceramic, 1.0 μ F, 100 V, \pm 10%, X7S	TDK	CGA4J3X7S2A105K125AE
6	3	C90, C91, C92	Capacitor, Ceramic, 1.0 μ F, 25 V, \pm 10%, X5R	Murata	GRM188R61E105KA12D
7	6	C71, C72, C77, C78, C80, C81	Capacitor, Ceramic, 100 nF, \pm 10%, 25 V, X7R	TDK	C1608X7R1E104K080AA
8	9	C2_1, C2_2, C4_1, C4_2, C5_1, C5_2, C57, C63, C70	Capacitor, Ceramic, 100 nF, \pm 10%, 25 V, X7R	TDK	C1005X7R1E104K050BB
9	2	C3_1, C3_2	Capacitor, Ceramic, 22 nF, \pm 10%, 25 V, X7R	TDK	C1005X7R1E223K050BB
10	12	C11_1, C11_2, C12_1, C12_2, C13_1, C13_2, C14_1, C14_2, C55, C66, C67, C68	Capacitor, Ceramic, 10 nF, \pm 10%, 100 V, X7S	TDK	C1005X7S2A103M050BB
11	2	C53, C54	Capacitor, Ceramic, 2.2 nF, \pm 10%, 50 V, X7R	Yageo	CC0402KRX7R9BB222
12	1	C56	Capacitor, Ceramic, 1 nF, \pm 10%, 50 V, X7R	Yageo	CC0402KRX7R9BB102
13	2	C82, C83	Capacitor, Ceramic, 100 pF, \pm 5%, 50 V, NPO	TDK	C1608C0G1H101J080AA
14	1	C84	Capacitor, Ceramic, 47 pF, \pm 5%, 50 V, NPO	Yageo	CC0402JRNPO9BN470
15	5	C42_1, C42_2, C43_1, C43_2, C75	Capacitor, Ceramic, 22 pF, \pm 5%, 50 V, NPO	TDK	C1005C0G1H220J050BA
16	1	RT1	Resistor, 470 K Ω , \pm 3%, 1/10 W, Th@25°C	Murata	NCP15WM474E03RC
17	1	R57	Resistor, 374 K Ω , \pm 1%, 1/10 W	Panasonic	ERJ-3EKF3743V
18	1	R58	Resistor, 124 K Ω , \pm 1%, 1/10 W	Panasonic	ERJ-2RKF1243X
19	1	R51	Resistor, 280 K Ω , \pm 1%, 1/10 W	Panasonic	ERJ-2RKF2803X
20	1	R70	Resistor, 47 K Ω , \pm 5%, 1/10 W	Stackpole	RMCF0603JT47K0
21	1	R59	Resistor, 45.3 K Ω , \pm 1%, 1/10 W	Panasonic	ERJ-2RKF4532X
22	1	R50	Resistor, 40.2 K Ω , \pm 1%, 1/16 W	Yageo	RC0402FR-0740K2L
23	2	R3_1, R3_2	Resistor, 27 K Ω , \pm 1%, \pm 1/16 W	Panasonic	ERJ-2RKF2702X
24	1	R54	Resistor, 15 K Ω , \pm 5%, 1/16 W	Yageo	RC0402JR-0715KL
25	1	R73	Resistor, 10 K Ω , \pm 1%, 1/10 W	Stackpole	RMCF0603FT10K0
26	2	R52, R75	Resistor, 10 K Ω , \pm 1%, 1/10 W	Panasonic	ERJ-2RKF1002X
27	1	R47	Resistor, 6.04 K Ω , \pm 1%, 1/10 W	Panasonic	ERJ-2RKF6041X
28	1	R49	Resistor, 3.3 K Ω , \pm 1%, 1/10 W	Panasonic	ERJ-2RKF3301X
29	1	R48	Resistor, 2.7 K Ω , \pm 1%, 1/10 W	Panasonic	ERJ-2RKF2741X
30	1	R71, R78	Resistor, 390 Ω , \pm 1%, 1/10 W	Stackpole	RMCF0603FT390R
31	2	R83	Resistor, 191 Ω , \pm 1%, 1/10 W	Panasonic	ERJ-3EKF1910V
32	2	R72, R77	Resistor, 124 Ω , \pm 1%, 1/10 W	Panasonic	ERJ-3EKF1240V
33	1	R82	Resistor, 31.6 Ω , \pm 1%, 1/10 W	Panasonic	ERJ-3EKF31R6V
34	2	R2_1, R2_2	Resistor, 20 Ω , \pm 1%, 1/16 W	Stackpole	RMCF0402FT20R0
35	3	R55, R56, R84	Resistor, 10 Ω , \pm 1%, 1/16 W	Yageo	RC0402FR-0710RL
36	2	R4_1, R4_2	Resistor, 4.7 Ω , \pm 1%, \pm 1/16 W	Yageo	RC0402FR-074R7L
37	6	R10_1, R10_2, R11_1, R11_2, R60, R61	Resistor, 2.2 Ω , \pm 1%, 1/16 W	Yageo	RC0402JR-072R2L
38	1	R62	Resistor, 24 m Ω , \pm 1%, 1W	Susumu	PRL1632-R024-F-T1
39	1	L60	Inductor, 10 μ H, \pm 20%, 3.5 A, 33 m Ω , Resonance = 40 MHz, Frequency Tested = 100 KHz	Würth	744314101
40	1	Lzvs12	Inductor, 500 nH, Q = 180, 50 MHz, DCR = 16.5 m Ω , I _{rms} = 4.3 A	Coilcraft	2929SQ-501JEB
41	10	D2_1, D2_2, D3_1, D_2, D71, D72, D77, D78, D82, D83	Diode, Schottky Diode, 30 V, VF = 370 mV @ 1 mA, 30 mA	Diodes Inc	SDM03U40-7
42	2	D1_1, D1_2	Diode, Schottky, 100 V, 0.2 A, VF = 1 V @ 200 mA	ST Microelectronics	BAT41KFILM
43	2	D4_1, D4_2	Diode, Zener, 5.1 V, 150 mW \pm 5%	Bourns Inc.	CD0603-Z5V1
44	6	Q10_1, Q10_2, Q11_1, Q11_2, Q60, Q61	eGaN [®] FET, 100 V, 6 A, 30 m Ω	EPC	EPC2007C

(continued on next page)

Table 3: Bill of Materials - Amplifier Board (continued)					
Item	Qty	Reference	Part Description	Manufacturer	Part #
45	2	Q4_1, Q4_2	eGaN® FET, 100 V, 0.5 A, 2.8 Ω	EPC	EPC2038
46	1	U90	IC's, 5 V LDO, 250 mA, up to 16 V _{IN} , V _{dropout} = 0.33 V @ 250 mA	Microchip	MCP1703T-5002E/MC
47	3	U1_1, U1_2, U60	IC's, Gate Driver, 5.2 VDC, 1.2 A, 4.5 V to 5.5 V	Texas Instruments	LM5113TME/NOPB
48	1	U50	IC's, Step Down Controller, 1.07 MHz, 6 V to 36 V	Linear Technologies	LT3741EUF#PBF
49	3	U71, U77, U81	IC's, Logic 2 NAND Gate, 1.65 V to 5.5 V, ± 24 mA	Fairchild	NC7SZ00L6X
50	3	U72, U78, U80	IC's, 2 Input NAND Gate, Tiny Logic, 1.65 V to 5.5 V, ± 32 mA	Fairchild	NC7SZ08L6X
51	1	U70	IC's, Programmable Oscillator 1.5 to 60 MHz, V _{IN} = 1.8 V/2.5 V/2.8 V/3.0 V/3.3 V/5.0 V	EPSON	SG-8002CE-PHB
52	2	TP1, TP2	Test Point, Test Point Subminiature	Keystone	5015
53	0.5	GP1_1, GP1_2, J61, J51, JP60, J70, J71, J75, JP70, J90 (See Note 1)	Header, Male Vertical, 36 Pin. 230" Contact Height, .1" Center Pitch	FCI	68001-236HLF
54	1	J1	Connector, RP-SMA Plug, 50 Ω	Linx	CONREVSMA013.062
55	1	J50	Connector, Male Locking Header, WR-WTB 3.96 mm, .156" Center to Center Pitch 2 pin	Würth	645 002 114 822
Optional Components					
1	1	C73	Capacitor, DNP 22 pF, 25 V	DNP	DNP
2	7	P49, P71, P72, P77, P78, P82, P83	Potentiometer, DNP 1 k, 10 k	DNP	DNP
3	2	Lzvs1, Lzvs2	Inductor, DNP	DNP	DNP
4	2	JMP1, JP61	Jumper, DNP Jumper with Test Point 1X2 Pin 0.100" Pitch	DNP	DNP

EPC would like to acknowledge Würth Electronics (www.we-online.com/web/en/wuerth_elektronik/start.php) for their support of this project.

Note 1: (36 pin Header to be cut as follows) (18)

(GP_1, GP_2, J61) cut 1 pin

(J51, J70, J71, J75, JP70, J90) cut 2 pins

(JP60) cut 3 pins

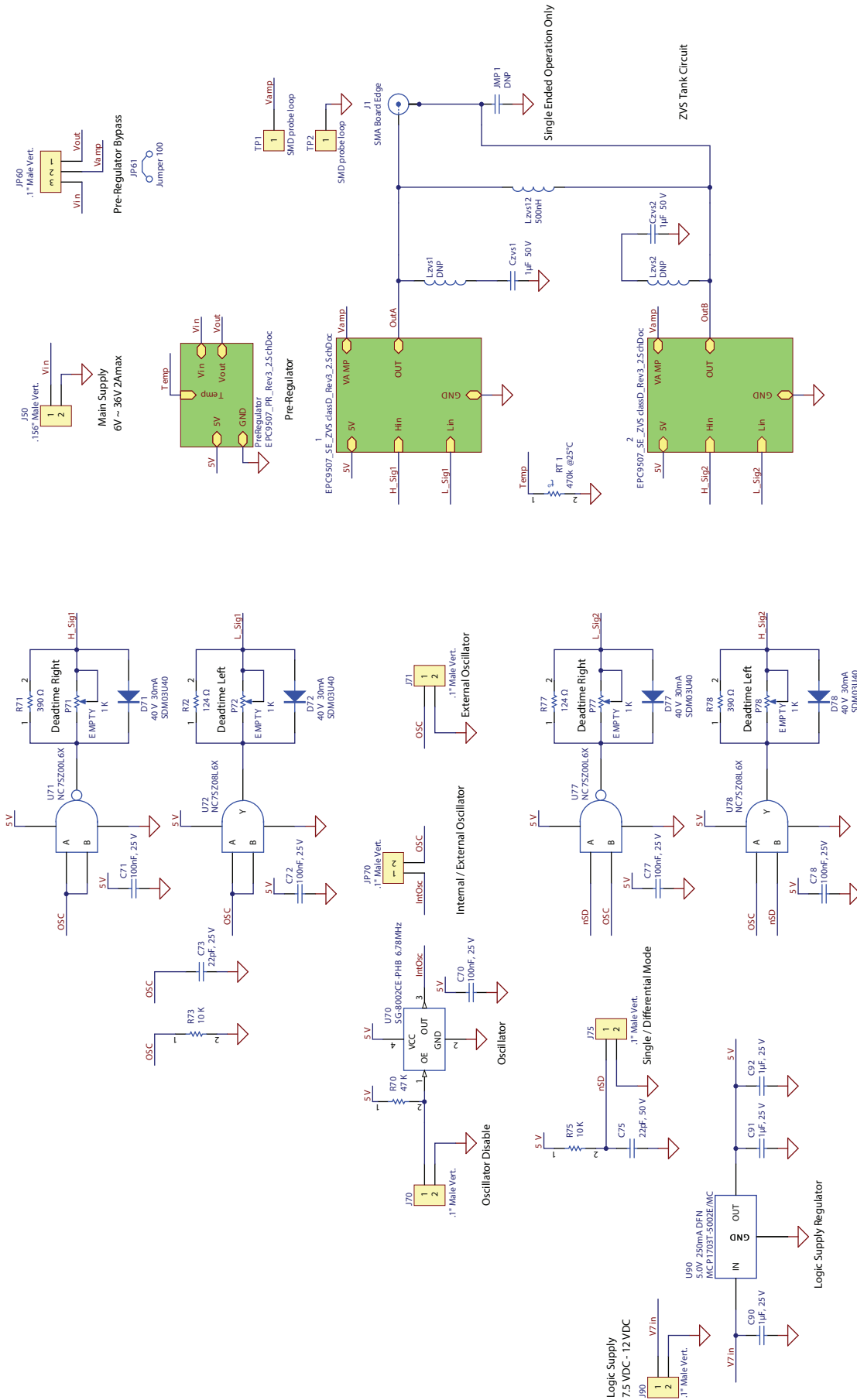

Figure 5: EPC9507 ZVS Class-D Amplifier Schematic Rev 3.2

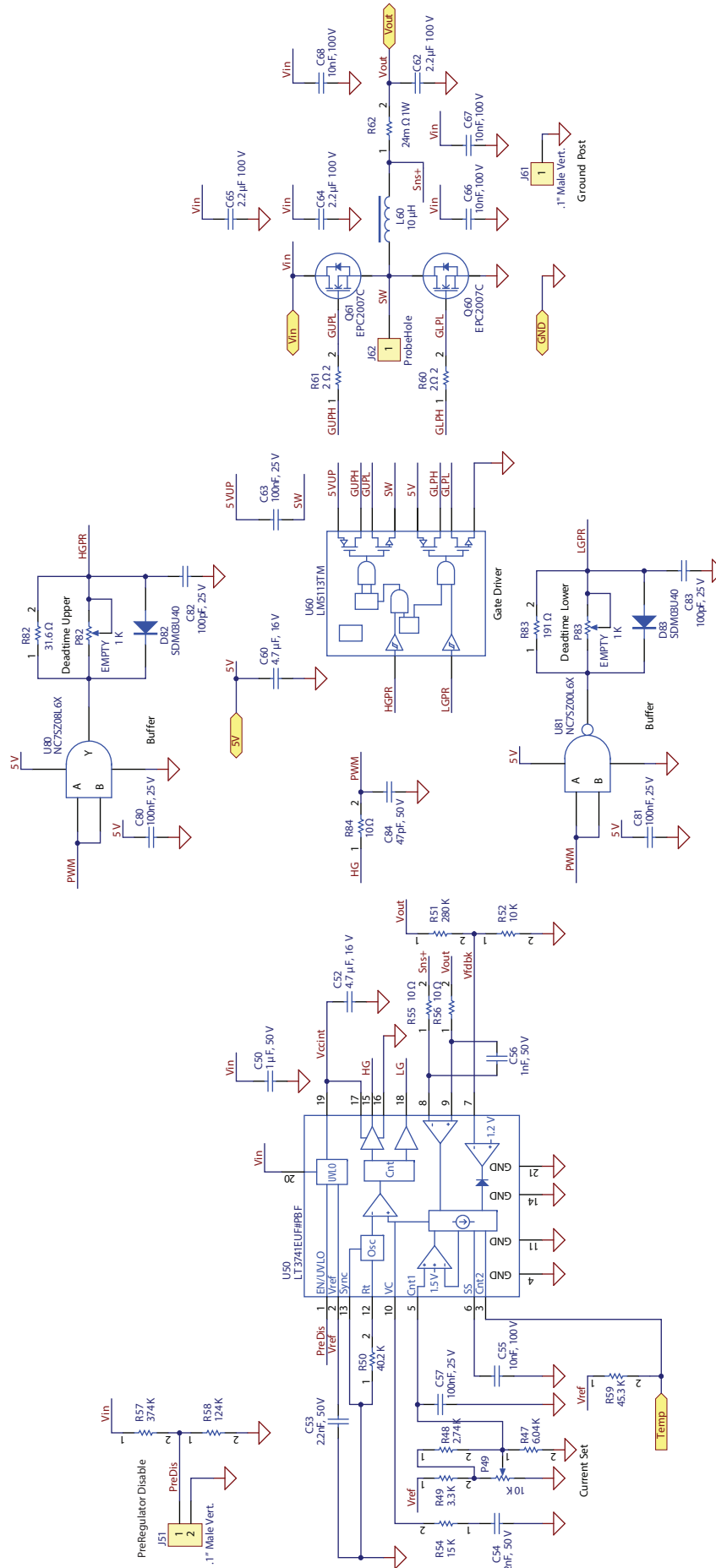

Figure 7: EPC9507 Pre-Regulator Schematic

For More Information:

Please contact info@epc-co.com
or your local sales representative

Visit our website:

www.epc-co.com

Sign-up to receive
EPC updates at
bit.ly/EPCupdates
or text "EPC" to 22828



EPC Products are distributed through Digi-Key.

www.digikey.com

Demonstration Board Warning and Disclaimer

The EPC9507 board is intended for product evaluation purposes only and is not intended for commercial use. Replace components on the Evaluation Board only with those parts shown on the parts list (or Bill of Materials) in the Quick Start Guide. Contact an authorized EPC representative with any questions.

This board is intended to be used by certified professionals, in a lab environment, following proper safety procedures. Use at your own risk.

As an evaluation tool, this board is not designed for compliance with the European Union directive on electromagnetic compatibility or any other such directives or regulations. As board builds are at times subject to product availability, it is possible that boards may contain components or assembly materials that are not RoHS compliant. Efficient Power Conversion Corporation (EPC) makes no guarantee that the purchased board is 100% RoHS compliant.

The Evaluation board (or kit) is for demonstration purposes only and neither the Board nor this Quick Start Guide constitute a sales contract or create any kind of warranty, whether express or implied, as to the applications or products involved.

Disclaimer: EPC reserves the right at any time, without notice, to make changes to any products described herein to improve reliability, function, or design. EPC does not assume any liability arising out of the application or use of any product or circuit described herein; neither does it convey any license under its patent rights, or other intellectual property whatsoever, nor the rights of others.

The Evaluation board (or kit) is for demonstration purposes only and neither the Board nor this Quick Start Guide constitute a sales contract or create any kind of warranty, whether express or implied, as to the applications or products involved.

Disclaimer: EPC reserves the right at any time, without notice, to make changes to any products described herein to improve reliability, function, or design. EPC does not assume any liability arising out of the application or use of any product or circuit described herein; neither does it convey any license under its patent rights, or other intellectual property whatsoever, nor the rights of others.