

Multi-Phase PWM Controller for CPU Core Power Supply

General Description

The RT8859M is a VR12/IMVP7 compliant CPU power controller which includes two voltage rails : a 4/3/2/1 phase synchronous buck controller, the CORE VR, and a single phase buck controller, the AXG VR. The RT8859M adopts G-NAVP[™] (Green Native AVP), which is Richtek's proprietary topology derived from finite DC gain compensator with current mode control, making it an easy setting PWM controller, meeting all Intel CPU requirements of AVP (Active Voltage Positioning). Based on the G-NAVP[™] topology, the RT8859M also features a quick response mechanism for optimized AVP performance during load transient. The RT8859M supports mode transition function with various operating states. A serial VID (SVID) interface is built in the RT8859M to communicate with Intel VR12/IMVP7 compliant CPU. The RT8859M supports VID on-the-fly function with three different slew rates: Fast, Slow and Decay. By utilizing the G-NAVP[™] topology, the operating frequency of the RT8859M varies with VID, load and input voltage to further enhance the efficiency even in CCM. The built-in high accuracy DAC converts the SVID code ranging from 0.25V to 1.52V with 5mV per step. The RT8859M integrates a high accuracy ADC for platform setting functions, such as no-load offset or over-current level. The RT8859M provides VR ready output signals of both CORE VR and AXG VR. It also features complete fault protection functions including over voltage, under voltage, negative voltage, over current and under voltage lockout. The RT8859M is available in a WQFN-56L 7x7 small foot print package.

Applications

- VR12 / IMVP7 Intel Core Supply
- Notebook/Desktop Computer/ Servers Multi-phase CPU Core Supply
- AVP Step-Down Converter

Features

- 4/3/2/1 + 1 Phase PWM Controller
- G-NAVP[™] Topology
- Serial VID Interface
- 0.5% DAC Accuracy
- Differential Remote Voltage Sensing
- Built-in ADC for Platform Programming
- Accurate Current Balance
- System Thermal Compensated AVP
- Diode Emulation Mode at Light Load Condition for Multiple and Single Phase
- Fast Transient Response
- VR12 / IMVP7 Compatible Power Management States
- VR Ready Indicator
- Thermal Throttling
- Current Monitor Output
- Switching Frequency up to 1MHz per Phase
- OVP, UVP, OCP, NVP, UVLO
- Slew Rate Setting/Address Flip Function
- External No-Load Offset Setting for both Rails
- DVID Improvement
- Small 56-Lead WQFN Package
- RoHS Compliant and Halogen Free

Ordering Information

RT8859M □ □

- Package Type
QW : WQFN-56L 7x7 (W-Type)
- Lead Plating System
G : Green (Halogen Free and Pb Free)
Z : ECO (Ecological Element with Halogen Free and Pb free)

Note :

Richtek products are :

- ▶ RoHS compliant and compatible with the current requirements of IPC/JEDEC J-STD-020.
- ▶ Suitable for use in SnPb or Pb-free soldering processes.

Pin Configurations

(TOP VIEW)

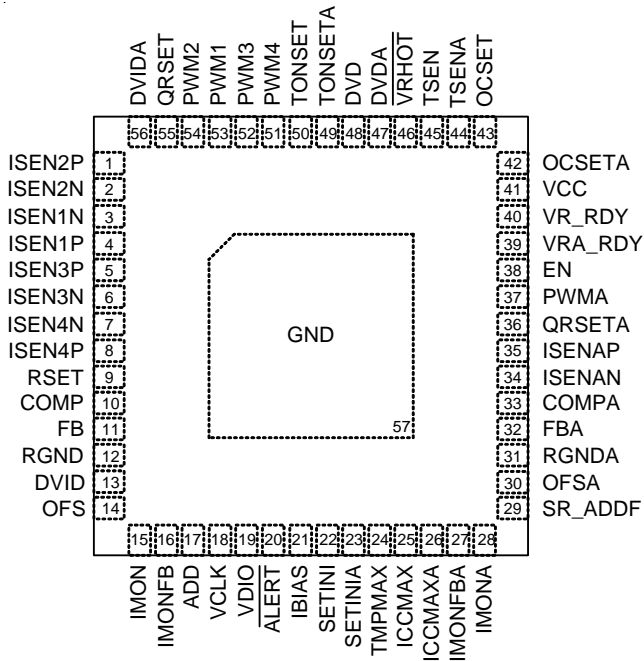

WQFN-56L 7x7

Marking Information

RT8859MGQW

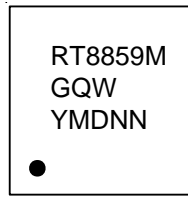

RT8859MGQW : Product Number
YMDNN : Date Code

RT8859MZQW

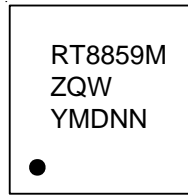

RT8859MZQW : Product Number
YMDNN : Date Code

Typical Application Circuit

Thermal Compensation at Voltage Loop

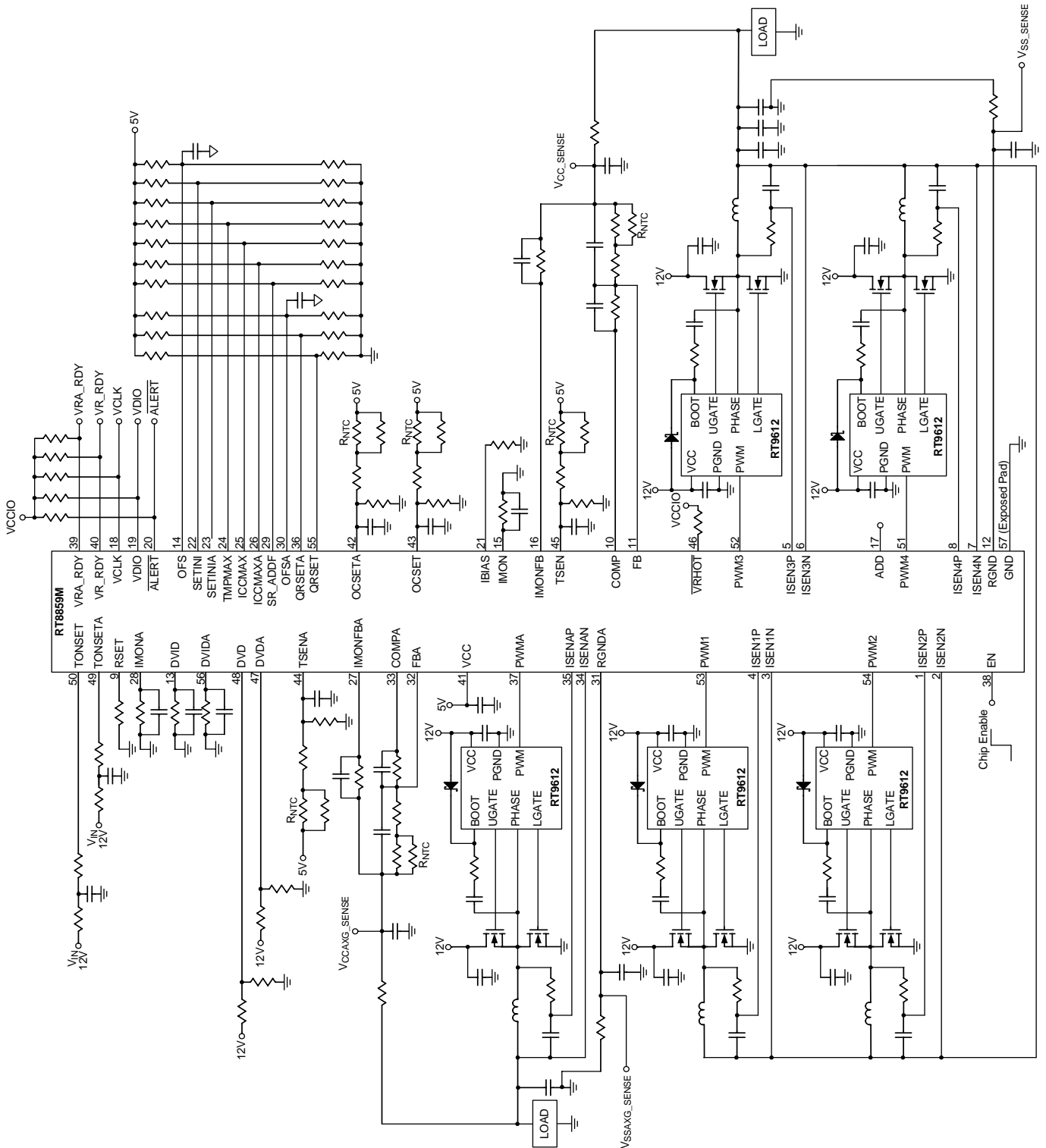

Thermal Compensation at Current Loop

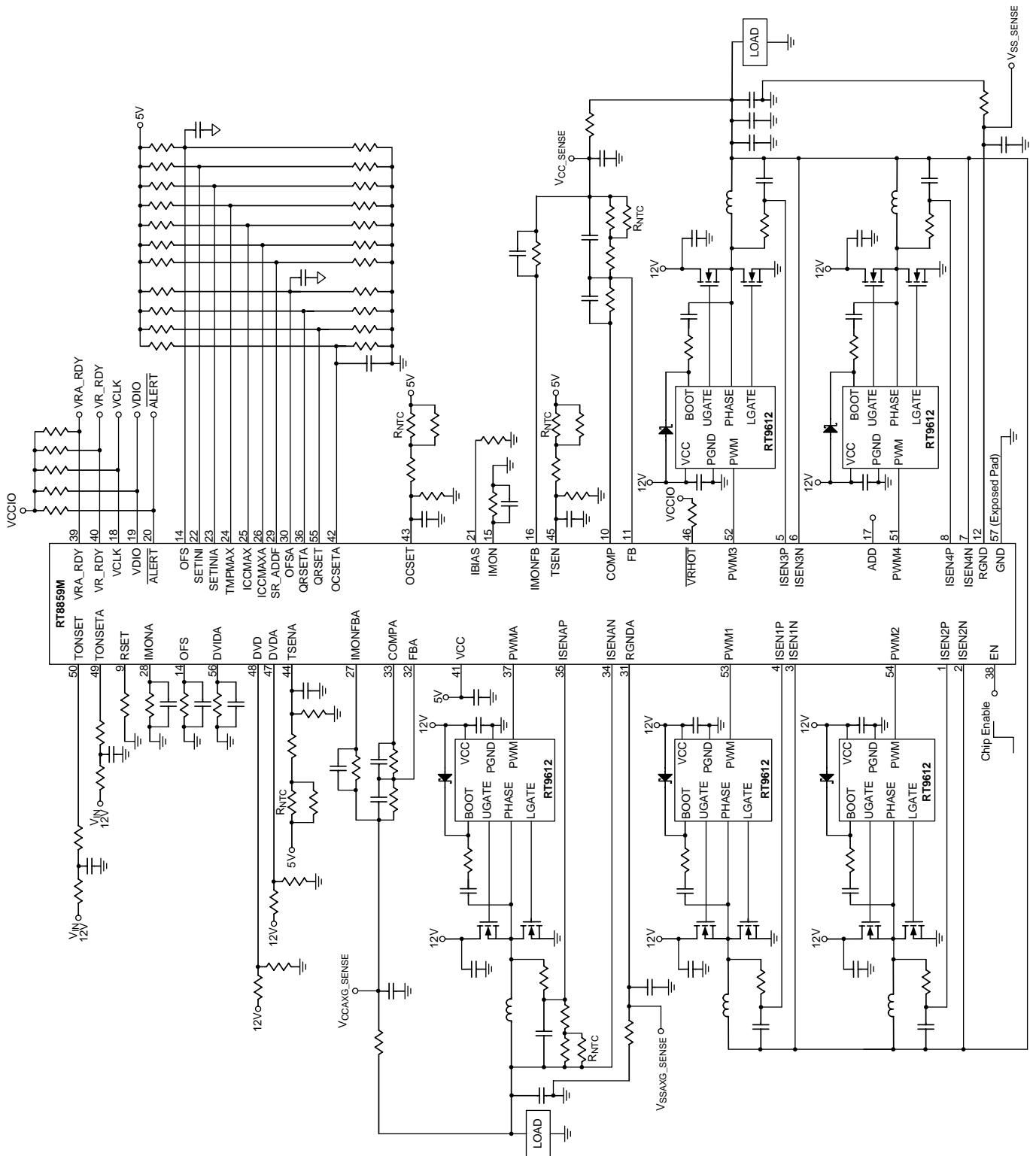

AXG VR Disabled

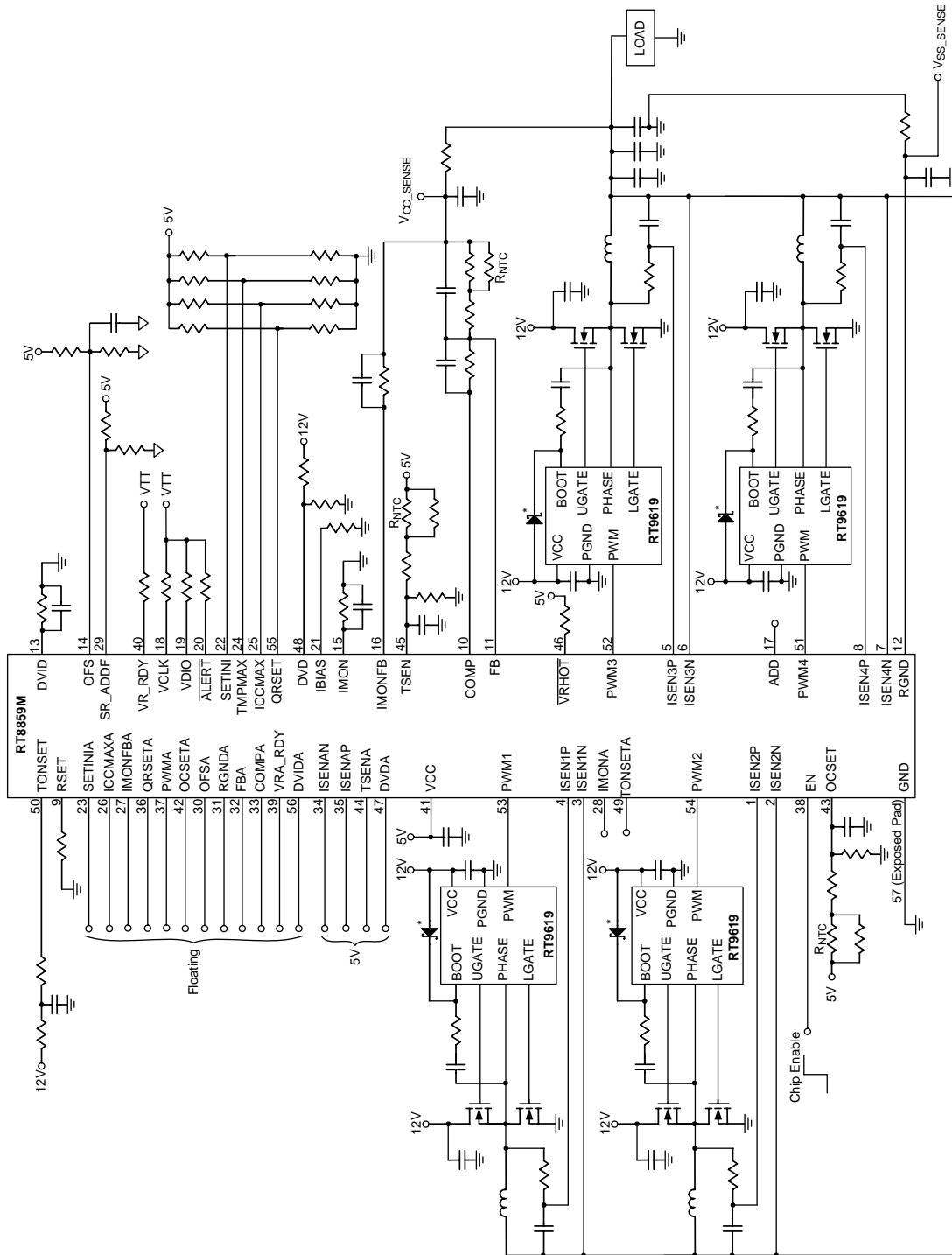

* : Optional

Functional Pin Description

Pin No.	Pin Name	Pin Function
4, 1, 5, 8	ISEN [1:4] P	Positive Current Sense Pin of Phase 1, 2, 3 and 4.
3, 2, 6, 7	ISEN [1:4] N	Negative Current Sense Pin of Phase 1, 2, 3 and 4.
9	RSET	Multi-Phase CORE VR Ramp Setting. This is used to set the multi-phase CORE VR loop external ramp slope.
10	COMP	Multi-Phase CORE VR Compensation. This pin is the output node of the error amplifier.
11	FB	Multi-Phase CORE VR Feedback. This is the negative input node of the error amplifier.
12	RGND	Return Ground for Multi-Phase CORE VR. This pin is the negative node of the differential remote voltage sensing.
13	DVID	Connect a resistor and a capacitor from this pin to GND to improve DVID performance. Short this pin to GND if this function is not needed.
14	OFS	Output Voltage Offset Setting.
15	IMON	Current Monitor Output. This pin outputs a voltage proportional to the output current.
16	IMONFB	Current Monitor Output Gain External Setting. Connect this pin with one resistor to CPU VCC_SENSE, while the IMON pin is connected to ground with another resistor. The current monitor output gain can be set by the ratio of these two resistors.
17	ADD	VR Address Setting Pin.
18	VCLK	Synchronous Clock from CPU.
19	VDIO	Controller and CPU Data Transmission Interface.
20	$\overline{\text{ALERT}}$	SVID Alert Pin (Active Low).
21	IBIAS	Internal Bias Current Setting. Connect this pin to GND via a resistor to set the internal current.
22	SETINI	CORE VR V _{INITIAL} Setting.
23	SETINIA	AXG VR V _{INITIALA} Setting.
24	TMPMAX	ADC Input for Multi-Phase CORE VR Maximum Temperature Setting. This pin is also used for AXG VR's offset selection.
25	ICCMAX	ADC Input for Multi-Phase CORE VR Maximum Current Setting. This pin is also used for CORE VR's offset selection.
26	ICCMAXA	ADC Input for Single-Phase AXG VR Maximum Current Setting.
27	IMONFBA	Single-Phase AXG VR Current Monitor Output Gain External Setting. Connect this pin with one resistor to AXG rail V _{CCAXG_SENSE} , while IMONA pin is connected to ground with another resistor. The current monitor output gain can be set by the ratio of these two resistors.
28	IMONA	Single-Phase AXG VR Current Monitor Output. This pin outputs a voltage proportional to the output current.
29	SR_ADDDF	Address Flip and DVID Slew Rate Setting. Set the pin to GND if fast slew rate= 10mV/ μ s and slow slew rate = 2.5mV/ μ s is used.
30	OFSA	AXG VR Output Voltage Offset Setting.
31	RGNDA	Return Ground for Single-Phase AXG VR. This pin is the negative node of the differential remote voltage sensing.

Pin No.	Pin Name	Pin Function
32	FBA	Single-Phase AXG VR Feedback. This is the negative input node of the error amplifier.
33	COMPA	Single-Phase AXG VR Compensation. This pin is the output node of the error amplifier.
34	ISENAN	Negative Current Sense Pin of Single-Phase AXG VR.
35	ISENAP	Positive Current Sense Pin of Single-Phase AXG VR.
36	QRSETA	Single-Phase AXG VR Quick Response Time Setting.
37	PWMA	PWM Output for Single-Phase AXG VR.
38	EN	Chip Enable (Active High)
39	VRA_RDY	VR Ready Indicator of Single-Phase AXG VR.
40	VR_RDY	VR Ready Indicator of Multi-Phase CORE VR.
41	VCC	Chip Power. Connect this pin to 5V via an RC filter.
42	OCSETA	Single-Phase AXG VR Over Current Protection Setting. Place a resistive voltage divider between VCC and ground and connect the joint of the voltage divider to the OCSETA pin. The voltage at the OCSET pin determines the over current threshold, I_{LIMITA} .
43	OCSET	Multi-Phase CORE VR Over Current Protection Setting. Place a resistive voltage divider between VCC and ground and connect the joint of the voltage divider to the OCSET pin. The voltage at the OCSET pin determines the over current threshold, I_{LIMIT} .
44	TSENA	Thermal Monitor Sense Point of AXG VR.
45	TSEN	Thermal Monitor Sense Point of CORE VR.
46	\overline{VRHOT}	Thermal Monitor Output (Active Low).
47	DVDA	Divided Voltage Detection of AXG VR. Connect this pin to a voltage divider from the single-phase power stage input power for input voltage detection.
48	DVD	Divided Voltage Detection of CORE VR. Connect this pin to a voltage divider from the multi-phase power stage input power for input voltage detection.
49	TONSETA	Single-Phase AXG VR On-Time Setting. Connect this pin to V_{IN} with one resistor to set ripple size in PWM mode.
50	TONSET	Multi-Phase CORE VR On-Time Setting. Connect this pin to V_{IN} with one resistor to set ripple size in PWM mode.
51, 52, 54, 53	PWM [4 :1]	PWM Output for CH1, 2, 3 and 4.
55	QRSET	Multi-Phase CORE VR Quick Response Time Setting.
56	DVIDA	Connect a resistor and a capacitor from this pin to GND to improve DVID performance. Short this pin to GND if this function is not needed.
57 (Exposed Pad)	GND	Ground. The exposed pad must be soldered to a large PCB and connected to GND for maximum power dissipation.

Function Block Diagram

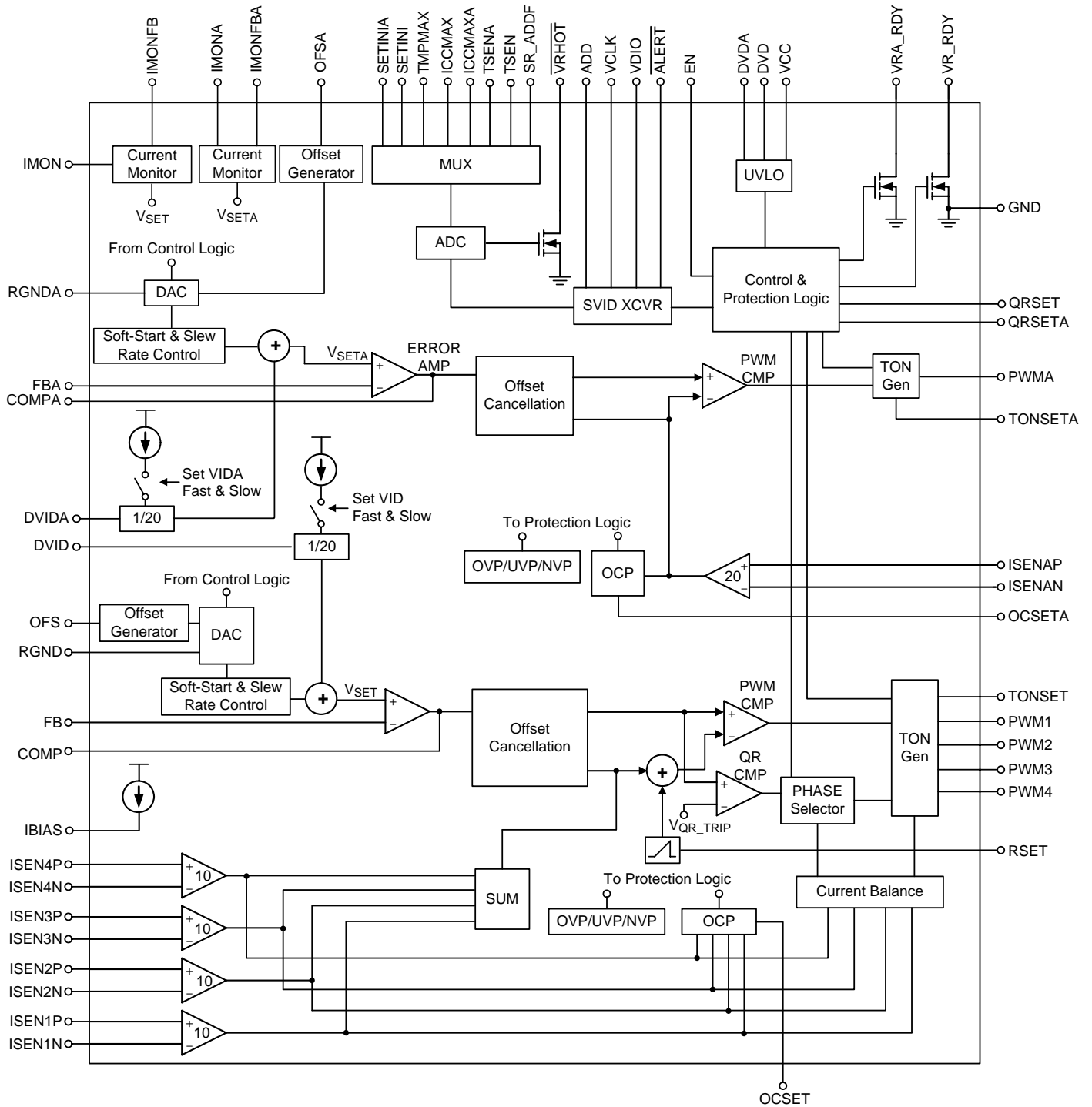

Table 1. VR12 VID Code Table

VID7	VID6	VID5	VID4	VID3	VID2	VID1	VID0	Hex		Voltage
0	0	0	0	0	0	0	0	0	0	0.000
0	0	0	0	0	0	0	1	0	1	0.250
0	0	0	0	0	0	1	0	0	2	0.255
0	0	0	0	0	0	1	1	0	3	0.260
0	0	0	0	0	1	0	0	0	4	0.265
0	0	0	0	0	1	0	1	0	5	0.270
0	0	0	0	0	1	1	0	0	6	0.275
0	0	0	0	0	1	1	1	0	7	0.280
0	0	0	0	1	0	0	0	0	8	0.285
0	0	0	0	1	0	0	1	0	9	0.290
0	0	0	0	1	0	1	0	0	A	0.295
0	0	0	0	1	0	1	1	0	B	0.300
0	0	0	0	1	1	0	0	0	C	0.305
0	0	0	0	1	1	0	1	0	D	0.310
0	0	0	0	1	1	1	0	0	E	0.315
0	0	0	0	1	1	1	1	0	F	0.320
0	0	0	1	0	0	0	0	1	0	0.325
0	0	0	1	0	0	0	1	1	1	0.330
0	0	0	1	0	0	1	0	1	2	0.335
0	0	0	1	0	0	1	1	1	3	0.340
0	0	0	1	0	1	0	0	1	4	0.345
0	0	0	1	0	1	0	1	1	5	0.350
0	0	0	1	0	1	1	0	1	6	0.355
0	0	0	1	0	1	1	1	1	7	0.360
0	0	0	1	1	0	0	0	1	8	0.365
0	0	0	1	1	0	0	1	1	9	0.370
0	0	0	1	1	0	1	0	1	A	0.375
0	0	0	1	1	0	1	1	1	B	0.380
0	0	0	1	1	1	0	0	1	C	0.385
0	0	0	1	1	1	0	1	1	D	0.390
0	0	0	1	1	1	1	0	1	E	0.395
0	0	0	1	1	1	1	1	1	F	0.400
0	0	1	0	0	0	0	0	2	0	0.405
0	0	1	0	0	0	0	1	2	1	0.410
0	0	1	0	0	0	1	0	2	2	0.415
0	0	1	0	0	0	1	1	2	3	0.420
0	0	1	0	0	1	0	0	2	4	0.425
0	0	1	0	0	1	0	1	2	5	0.430
0	0	1	0	0	1	1	0	2	6	0.435
0	0	1	0	0	1	1	1	2	7	0.440
0	0	1	0	1	0	0	0	2	8	0.445

VID7	VID6	VID5	VID4	VID3	VID2	VID1	VID0	Hex		Voltage
0	0	1	0	1	0	0	1	2	9	0.450
0	0	1	0	1	0	1	0	2	A	0.455
0	0	1	0	1	0	1	1	2	B	0.460
0	0	1	0	1	1	0	0	2	C	0.465
0	0	1	0	1	1	0	1	2	D	0.470
0	0	1	0	1	1	1	0	2	E	0.475
0	0	1	0	1	1	1	1	2	F	0.480
0	0	1	1	0	0	0	0	3	0	0.485
0	0	1	1	0	0	0	1	3	1	0.490
0	0	1	1	0	0	1	0	3	2	0.495
0	0	1	1	0	0	1	1	3	3	0.500
0	0	1	1	0	1	0	0	3	4	0.505
0	0	1	1	0	1	0	1	3	5	0.510
0	0	1	1	0	1	1	0	3	6	0.515
0	0	1	1	0	1	1	1	3	7	0.520
0	0	1	1	1	0	0	0	3	8	0.525
0	0	1	1	1	0	0	1	3	9	0.530
0	0	1	1	1	0	1	0	3	A	0.535
0	0	1	1	1	0	1	1	3	B	0.540
0	0	1	1	1	1	0	0	3	C	0.545
0	0	1	1	1	1	0	1	3	D	0.550
0	0	1	1	1	1	1	0	3	E	0.555
0	0	1	1	1	1	1	1	3	F	0.560
0	1	0	0	0	0	0	0	4	0	0.565
0	1	0	0	0	0	0	1	4	1	0.570
0	1	0	0	0	0	1	0	4	2	0.575
0	1	0	0	0	0	1	1	4	3	0.580
0	1	0	0	0	1	0	0	4	4	0.585
0	1	0	0	0	1	0	1	4	5	0.590
0	1	0	0	0	1	1	0	4	6	0.595
0	1	0	0	0	1	1	1	4	7	0.600
0	1	0	0	1	0	0	0	4	8	0.605
0	1	0	0	1	0	0	1	4	9	0.610
0	1	0	0	1	0	1	0	4	A	0.615
0	1	0	0	1	0	1	1	4	B	0.620
0	1	0	0	1	1	0	0	4	C	0.625
0	1	0	0	1	1	0	1	4	D	0.630
0	1	0	0	1	1	1	0	4	E	0.635
0	1	0	0	1	1	1	1	4	F	0.640
0	1	0	1	0	0	0	0	5	0	0.645
0	1	0	1	0	0	0	1	5	1	0.650
0	1	0	1	0	0	1	0	5	2	0.655

VID7	VID6	VID5	VID4	VID3	VID2	VID1	VID0	Hex		Voltage
0	1	0	1	0	0	1	1	5	3	0.660
0	1	0	1	0	1	0	0	5	4	0.665
0	1	0	1	0	1	0	1	5	5	0.670
0	1	0	1	0	1	1	0	5	6	0.675
0	1	0	1	0	1	1	1	5	7	0.680
0	1	0	1	1	0	0	0	5	8	0.685
0	1	0	1	1	0	0	1	5	9	0.690
0	1	0	1	1	0	1	0	5	A	0.695
0	1	0	1	1	0	1	1	5	B	0.700
0	1	0	1	1	1	0	0	5	C	0.705
0	1	0	1	1	1	0	1	5	D	0.710
0	1	0	1	1	1	1	0	5	E	0.715
0	1	0	1	1	1	1	1	5	F	0.720
0	1	1	0	0	0	0	0	6	0	0.725
0	1	1	0	0	0	0	1	6	1	0.730
0	1	1	0	0	0	1	0	6	2	0.735
0	1	1	0	0	0	1	1	6	3	0.740
0	1	1	0	0	1	0	0	6	4	0.745
0	1	1	0	0	1	0	1	6	5	0.750
0	1	1	0	0	1	1	0	6	6	0.755
0	1	1	0	0	1	1	1	6	7	0.760
0	1	1	0	1	0	0	0	6	8	0.765
0	1	1	0	1	0	0	1	6	9	0.770
0	1	1	0	1	0	1	0	6	A	0.775
0	1	1	0	1	0	1	1	6	B	0.780
0	1	1	0	1	1	0	0	6	C	0.785
0	1	1	0	1	1	0	1	6	D	0.790
0	1	1	0	1	1	1	0	6	E	0.795
0	1	1	0	1	1	1	1	6	F	0.800
0	1	1	1	0	0	0	0	7	0	0.805
0	1	1	1	0	0	0	1	7	1	0.810
0	1	1	1	0	0	1	0	7	2	0.815
0	1	1	1	0	0	1	1	7	3	0.820
0	1	1	1	0	1	0	0	7	4	0.825
0	1	1	1	0	1	0	1	7	5	0.830
0	1	1	1	0	1	1	0	7	6	0.835
0	1	1	1	0	1	1	1	7	7	0.840
0	1	1	1	1	0	0	0	7	8	0.845
0	1	1	1	1	0	0	1	7	9	0.850
0	1	1	1	1	0	1	0	7	A	0.855
0	1	1	1	1	0	1	1	7	B	0.860

VID7	VID6	VID5	VID4	VID3	VID2	VID1	VID0	Hex		Voltage
0	1	1	1	1	1	0	0	7	C	0.865
0	1	1	1	1	1	0	1	7	D	0.870
0	1	1	1	1	1	1	0	7	E	0.875
0	1	1	1	1	1	1	1	7	F	0.880
1	0	0	0	0	0	0	0	8	0	0.885
1	0	0	0	0	0	0	1	8	1	0.890
1	0	0	0	0	0	1	0	8	2	0.895
1	0	0	0	0	0	1	1	8	3	0.900
1	0	0	0	0	1	0	0	8	4	0.905
1	0	0	0	0	1	0	1	8	5	0.910
1	0	0	0	0	1	1	0	8	6	0.915
1	0	0	0	0	1	1	1	8	7	0.920
1	0	0	0	1	0	0	0	8	8	0.925
1	0	0	0	1	0	0	1	8	9	0.930
1	0	0	0	1	0	1	0	8	A	0.935
1	0	0	0	1	0	1	1	8	B	0.940
1	0	0	0	1	1	0	0	8	C	0.945
1	0	0	0	1	1	0	1	8	D	0.950
1	0	0	0	1	1	1	0	8	E	0.955
1	0	0	0	1	1	1	1	8	F	0.960
1	0	0	1	0	0	0	0	9	0	0.965
1	0	0	1	0	0	0	1	9	1	0.970
1	0	0	1	0	0	1	0	9	2	0.975
1	0	0	1	0	0	1	1	9	3	0.980
1	0	0	1	0	1	0	0	9	4	0.985
1	0	0	1	0	1	0	1	9	5	0.990
1	0	0	1	0	1	1	0	9	6	0.995
1	0	0	1	0	1	1	1	9	7	1.000
1	0	0	1	1	0	0	0	9	8	1.005
1	0	0	1	1	0	0	1	9	9	1.010
1	0	0	1	1	0	1	0	9	A	1.015
1	0	0	1	1	0	1	1	9	B	1.020
1	0	0	1	1	1	0	0	9	C	1.025
1	0	0	1	1	1	0	1	9	D	1.030
1	0	0	1	1	1	1	0	9	E	1.035
1	0	0	1	1	1	1	1	9	F	1.040
1	0	1	0	0	0	0	0	A	0	1.045
1	0	1	0	0	0	0	1	A	1	1.050
1	0	1	0	0	0	1	0	A	2	1.055
1	0	1	0	0	0	1	1	A	3	1.060
1	0	1	0	0	1	0	0	A	4	1.065

VID7	VID6	VID5	VID4	VID3	VID2	VID1	VID0	Hex		Voltage
1	0	1	0	0	1	0	1	A	5	1.070
1	0	1	0	0	1	1	0	A	6	1.075
1	0	1	0	0	1	1	1	A	7	1.080
1	0	1	0	1	0	0	0	A	8	1.085
1	0	1	0	1	0	0	1	A	9	1.090
1	0	1	0	1	0	1	0	A	A	1.095
1	0	1	0	1	0	1	1	A	B	1.100
1	0	1	0	1	1	0	0	A	C	1.105
1	0	1	0	1	1	0	1	A	D	1.110
1	0	1	0	1	1	1	0	A	E	1.115
1	0	1	0	1	1	1	1	A	F	1.120
1	0	1	1	0	0	0	0	B	0	1.125
1	0	1	1	0	0	0	1	B	1	1.130
1	0	1	1	0	0	1	0	B	2	1.135
1	0	1	1	0	0	1	1	B	3	1.140
1	0	1	1	0	1	0	0	B	4	1.145
1	0	1	1	0	1	0	1	B	5	1.150
1	0	1	1	0	1	1	0	B	6	1.155
1	0	1	1	0	1	1	1	B	7	1.160
1	0	1	1	1	0	0	0	B	8	1.165
1	0	1	1	1	0	0	1	B	9	1.170
1	0	1	1	1	0	1	0	B	A	1.175
1	0	1	1	1	0	1	1	B	B	1.180
1	0	1	1	1	1	0	0	B	C	1.185
1	0	1	1	1	1	0	1	B	D	1.190
1	0	1	1	1	1	1	0	B	E	1.195
1	0	1	1	1	1	1	1	B	F	1.200
1	1	0	0	0	0	0	0	C	0	1.205
1	1	0	0	0	0	0	1	C	1	1.210
1	1	0	0	0	0	1	0	C	2	1.215
1	1	0	0	0	0	1	1	C	3	1.220
1	1	0	0	0	1	0	0	C	4	1.225
1	1	0	0	0	1	0	1	C	5	1.230
1	1	0	0	0	1	1	0	C	6	1.235
1	1	0	0	0	1	1	1	C	7	1.240
1	1	0	0	1	0	0	0	C	8	1.245
1	1	0	0	1	0	0	1	C	9	1.250
1	1	0	0	1	0	1	0	C	A	1.255
1	1	0	0	1	0	1	1	C	B	1.260
1	1	0	0	1	1	0	0	C	C	1.265
1	1	0	0	1	1	0	1	C	D	1.270

VID7	VID6	VID5	VID4	VID3	VID2	VID1	VID0	Hex		Voltage
1	1	0	0	1	1	1	0	C	E	1.275
1	1	0	0	1	1	1	1	C	F	1.280
1	1	0	1	0	0	0	0	D	0	1.285
1	1	0	1	0	0	0	1	D	1	1.290
1	1	0	1	0	0	1	0	D	2	1.295
1	1	0	1	0	0	1	1	D	3	1.300
1	1	0	1	0	1	0	0	D	4	1.305
1	1	0	1	0	1	0	1	D	5	1.310
1	1	0	1	0	1	1	0	D	6	1.315
1	1	0	1	0	1	1	1	D	7	1.320
1	1	0	1	1	0	0	0	D	8	1.325
1	1	0	1	1	0	0	1	D	9	1.330
1	1	0	1	1	0	1	0	D	A	1.335
1	1	0	1	1	0	1	1	D	B	1.340
1	1	0	1	1	1	0	0	D	C	1.345
1	1	0	1	1	1	0	1	D	D	1.350
1	1	0	1	1	1	1	0	D	E	1.355
1	1	0	1	1	1	1	1	D	F	1.360
1	1	1	0	0	0	0	0	E	0	1.365
1	1	1	0	0	0	0	1	E	1	1.370
1	1	1	0	0	0	1	0	E	2	1.375
1	1	1	0	0	0	1	1	E	3	1.380
1	1	1	0	0	1	0	0	E	4	1.385
1	1	1	0	0	1	0	1	E	5	1.390
1	1	1	0	0	1	1	0	E	6	1.395
1	1	1	0	0	1	1	1	E	7	1.400
1	1	1	0	1	0	0	0	E	8	1.405
1	1	1	0	1	0	0	1	E	9	1.410
1	1	1	0	1	0	1	0	E	A	1.415
1	1	1	0	1	0	1	1	E	B	1.420
1	1	1	0	1	1	0	0	E	C	1.425
1	1	1	0	1	1	0	1	E	D	1.430
1	1	1	0	1	1	1	0	E	E	1.435
1	1	1	0	1	1	1	1	E	F	1.440
1	1	1	1	0	0	0	0	F	0	1.445
1	1	1	1	0	0	0	1	F	1	1.450
1	1	1	1	0	0	1	0	F	2	1.455
1	1	1	1	0	0	1	1	F	3	1.460
1	1	1	1	0	1	0	0	F	4	1.465
1	1	1	1	0	1	0	1	F	5	1.470
1	1	1	1	0	1	1	0	F	6	1.475

VID7	VID6	VID5	VID4	VID3	VID2	VID1	VID0	Hex		Voltage
1	1	1	1	0	1	1	1	F	7	1.480
1	1	1	1	1	0	0	0	F	8	1.485
1	1	1	1	1	0	0	1	F	9	1.490
1	1	1	1	1	0	1	0	F	A	1.495
1	1	1	1	1	0	1	1	F	B	1.500
1	1	1	1	1	1	0	0	F	C	1.505
1	1	1	1	1	1	0	1	F	D	1.510
1	1	1	1	1	1	1	0	F	E	1.515
1	1	1	1	1	1	1	1	F	F	1.520

Table 2. Serial VID Command

Code	Commands	Master Payload Contents	Slave Payload Contents	Description
00h	Not Supported	N/A	N/A	N/A
01h	SetVID_Fast	VID code	N/A	Set new target VID code, VR jumps to new VID target with controlled default “fast” slew rate 12.5mV/μs.
02h	SetVID_Slow	VID code	N/A	Set new target VID code, VR jumps to new VID target with controlled default “slow” slew rate 3.125mV/μs.
03h	SetVID_Decay	VID code	N/A	Set new target VID code, VR jumps to new VID target, but does not control the slew rate. The output voltage decays at a rate proportional to the load current
04h	SetPS	Byte indicating power states	N/A	Set power state
05h	SetRegADR	Pointer of registers in data table	N/A	Set the pointer of the data register
06h	SetRegDAT	New data register content	N/A	Write the contents to the data register
07h	GetReg	Pointer of registers in data table	Specified register contents	Slave returns the contents of the specified register as the payload.
08h - 1Fh	Not Supported	N/A	N/A	N/A

Table 3. SVID Data and Configuration Register

Index	Register Name	Description	Access	Default
00h	Vendor_ID	Vendor ID	RO	1Eh
01h	Product_ID	Product ID	RO	59h
02h	Product_Revision	Product Revision	RO	03h
05h	Protocol_Version	SVID Protocol version	RO	01h
06h	VR_Capability	Bit mapped register, identifies the SVID VR Capabilities and which of the optional telemetry register are supported.	RO	81h
10h	Status_1	Data register containing the status of VR	R-M, W-PWM	00h
11h	Status_2	Data register containing the status of transmission.	R-M, W-PWM	00h
12h	Temperature_Zone	Data register showing temperature Zone that have been entered.	R-M, W-PWM	00h
15h	Output_Current	Data register showing direct ADC conversion of output current, scaled to ICC_MAX = ADC full range. Binary format (IE : 64h = 100/255 ICC_MAX)	R-M, W-PWM	00h
1Ch	Status_2_Lastread	The register contains a copy of the Status_2	R-M, W-PWM	00h
21h	ICC_Max	Data register containing the maximum ICC the platform supports. Binary format in A. (IE : 64h = 100A)	RO, Platform	N/A
22h	Temp_Max	Data register containing the maximum temperature the platform supports. Binary format in °C. (IE : 64h = 100°C) Not supported by AXG VR.	RO, Platform	N/A
24h	SR_fast	Data register containing the capability of fast slew rate the platform can sustain. Binary format in mV/μs. (IE : 0Ah = 10 mV/μs)	RO	0Ah
25h	SR_slow	Data register containing the capability of slow slew rate. Binary format in mV/μs. (IE : 02h = 2mV/μs)	RO	02h
30h	VOUT_Max	The register is programmed by the master and sets the maximum VID.	RW, Master	FBh
31h	VID_Setting	Data register containing currently programmed VID	RW, Master	00h
32h	Power_State	Register containing the current programmed power state	RW, Master	00h
33h	Offset	Set offset in VID steps	RW, Master	00h
34h	Multi_VR_Config	Bit mapped data register which configures multiple VRs' behavior on the same bus	RW, Master	00h
35h	Pointer	Scratch pad register for temporary storage of the SetRegADR pointer register	RW, Master	30h

Notes :

RO = Read Only

RW = Read/Write

R-M = Read by Master

W-PWM = Write by PWM only

Platform = programmed by platform

Master = programmed by the master

PWM = programmed by the VR control IC

Absolute Maximum Ratings (Note 1)

- VCC to GND ----- -0.3V to 6.5V
- RGNDx to GND ----- -0.3V to 0.3V
- TONSETx to GND ----- -0.3V to 28V
- Others ----- -0.3V to (VCC + 0.3V)
- Power Dissipation, P_D @ T_A = 25°C
 WQFN-56L 7x7 ----- 3.226W
- Package Thermal Resistance (Note 2)
 WQFN-56L 7x7, θ_{JA} ----- 31°C/W
 WQFN-56L 7x7, θ_{JC} ----- 6°C/W
- Junction Temperature ----- 150°C
- Lead Temperature (Soldering, 10 sec.) ----- 260°C
- Storage Temperature Range ----- -65°C to 150°C
- ESD Susceptibility (Note 3)
 HBM (Human Body Model) ----- 2kV

Recommended Operating Conditions (Note 4)

- Supply Voltage, VCC ----- 4.5V to 5.5V
- Junction Temperature Range ----- -40°C to 125°C
- Ambient Temperature Range ----- -40°C to 85°C

Electrical Characteristics

(V_{CC} = 5V, T_A = 25°C, unless otherwise specified)

Parameter	Symbol	Test Conditions	Min	Typ	Max	Unit
Supply Input						
Supply Current	I _{VCC}	V _{EN} = 1.05V, Not Switching	--	12	20	mA
Shutdown Current	I _{SHDN}	V _{EN} = 0V	--	--	5	μA
Reference and DAC						
DAC Accuracy	V _{FB}	V _{DAC} = 1.000 to 1.520 (No Load, Active Mode)	-0.5	0	0.5	%VID
		V _{DAC} = 0.800 to 1.000	-5	0	5	mV
		V _{DAC} = 0.500 to 0.800	-8	0	8	mV
		V _{DAC} = 0.250 to 0.500	-8	0	8	mV
RGND Current						
RGND Current	I _{RGND}	V _{EN} = 1.05V, Not Switching	--	--	500	μA
Slew Rate						
Dynamic VID Slew Rate	SR	Set VID Slow, SR_ADDF pin = 0V	2.5	3.125	3.75	mV/μs
		Set VID Fast, SR_ADDF pin = 0V	10	12.5	15	
Error Amplifier						
DC Gain	A _{DC}	R _{LOAD} = 47kΩ	--	80	--	dB
Gain-Bandwidth Product	GBW	C _{LOAD} = 5pF	--	10	--	MHz
Slew Rate	SR	C _{LOAD} = 10pF (Gain = -4, R _{LOAD} = 47kΩ, V _{OUT} = 0.5V to -3V)	--	5	--	V/μs

Parameter	Symbol	Test Conditions	Min	Typ	Max	Unit
Output Voltage Range	V _{COMP}	R _{LOAD} = 47kΩ	0.3	--	3.6	V
MAX Source/Sink Current	I _{OUTEA}	V _{COMP} = 2V	--	250	--	μA
Current Sense Amplifier						
Input Offset Voltage	V _{OCS}		-0.75	--	0.75	mV
Impedance at Negative Input	R _{ISENxN}		1	--	--	MΩ
Impedance at Positive Input	R _{ISENxP}		1	--	--	MΩ
DC Gain		CORE VR	--	10	--	V/V
		AXG VR	--	20	--	
Input Range	V _{ISEN_IN}		-50	--	100	mV
V _{ISEN} Linearity	V _{ISEN_ACC}	-30mV < V _{ISEN_IN} < 50mV	-1	--	1	%
t_{ON} Setting						
TONSETx Pin Voltage	V _{TON}	I _{RTON} = 80μA, V _{DAC} = 0.75V	--	1.07	--	V
CCM On-Time Setting	t _{ON}	I _{RTON} = 80μA, PS0, PS1	275	305	335	ns
TONSETx Input Current Range	I _{RTON}		25	--	280	μA
On-Time in PS2 (Core only)	t _{ON_PS2}	With Respect to PS0 t _{ON}	--	85	--	%
Minimum Off-Time	t _{OFF}		--	250	--	ns
IBIAS						
IBIAS Pin Voltage	V _{IBIAS}	R _{IBIAS} = 53.6kΩ	2.09	2.14	2.19	V
QRSET						
Quick Response On-Time Setting	t _{ONx_QR}	V _{DAC} = 0.75V, V _{QRSET} = 1.2V, I _{RTON} = 80μA	--	305	--	ns
QRSET Source Current	I _{QRSET}	Before UVLO	--	80	--	μA
No Load Line Setting Threshold	V _{IH}	QRSET Voltage before UVLO, Relative to V _{CC}	V _{CC} - 0.5	--	--	V
	V _{IL}		--	--	V _{CC} - 1.8	V
OFS Function						
OFS Enable/Disable Threshold Voltage	V _{EN_OFS}	V _{OFS} > V _{EN_OFS} before EN rising	0.7	1.2	--	V
Offset Voltage	V _{OUT}	VID = 1V, V _{OFS} = 1.83V	1.62	1.63	1.64	V
		VID = 1V, V _{OFS} = 0.9V	0.69	0.7	0.71	
		VID = 1V, V _{OFS} = 1.2V	0.9	1	1.01	
Impedance	R _{OFS}		1	--	--	MΩ
RSET Setting						
RSET Voltage	V _{RSET}	RSET Voltage, V _{DAC} = 1V	0.97	1	1.03	V
Zero Current Detection						
Zero Current Detection Threshold	V _{ZCD}	ISEN1P (AP) – ISEN1N (AN)	--	1	--	mV
Protection						
Under Voltage Lock-out (UVLO) Threshold	V _{UVLO}	Falling Edge, 100mV Hysteresis	4.04	4.24	4.44	V
	ΔV _{UVLO}	Falling Edge Hysteresis	--	100	--	mV
Absolute Over Voltage (OVP) Protection Threshold	V _{OVABS}	With respect to V _{OUT_Max}	100	150	200	mV

Parameter	Symbol	Test Conditions	Min	Typ	Max	Unit
Divided Input Voltage Detection (DVDx) Threshold	V _{DVDx}	V _{DVDx} Threshold	1.01	1.06	1.11	V
	V _{DVDHYS}	Falling Edge Hysteresis	--	25	--	mV
Delay of UVLO, DVDx	t _{UVLO}	Rising Above Threshold	--	3	--	μs
Delay of OVP	t _{OV}	V _{ISENxN} Rising Above Threshold, Pin OFS Disable	--	1	--	μs
Under Voltage Protection (UVP) Threshold	V _{UV}	Measured at ISEN1N/ISENAN with respect to unloaded output voltage (UOV) (for 0.8 < UOV < 1.52)	-350	-300	-250	mV
Delay of UVP	t _{UVP}	V _{ISENxN} Falling below Threshold	--	3	--	μs
Negative Voltage Protection Threshold	V _{NVP}	After OVP, Falling Edge	-100	-50	--	mV
Delay of NVP	t _{NVP}	V _{ISENxN} Falling below Threshold	--	1	--	μs
Current Limit Gain Setting (per phase)	G _{LIMIT}	G _{LIMIT} = V _{OCSET} / (V _{ISENxP} - V _{ISENxN}), V _{OCSET} = 2.400V, (V _{ISENxP} - V _{ISENxN}) = 50mV	43.2	48	52.8	V/V
		G _{LIMITA} = V _{OCSETA} / (V _{ISENAP} - V _{ISENAN}), V _{OCSETA} = 2.4V, (V _{ISENAP} - V _{ISENAN}) = 50mV	43.2	48	52.8	
Current Limit Latch Counter (per phase)	N _{LIM}	Times of UGATE Rising	--	15	--	Times
EN Input Threshold Voltage	Logic-High	V _{IH}	0.7	--	--	V
	Logic-Low	V _{IL}	--	--	0.3	
Logic Inputs						
EN Hysteresis	V _{ENHYS}		--	30	--	mV
Leakage Current of EN	I _{EN}		-1	--	1	μA
VCLK, VDIO Input Threshold Voltage	Logic-High	V _{IH}	0.665	--	--	V
	Logic-Low	V _{IL}	--	--	0.367	
VCLK, VDIO Hysteresis	V _{HYS}		--	70	--	mV
Leakage Current of ADD, VCLK, VDIO	I _{LEAK_IN}		-1	--	1	μA
ALERT						
ALERT Low Voltage	V _{ALERT}	I _{ALERT} = 10mA	--	--	0.13	V
Power On Sequence						
SVID Ready Delay Time	t _A	From EN = high until VR Controller is ready to accept SVID command	--	--	2	ms
VR_RDY Trip Threshold	V _{TH_VR_RDY}	V _{ISENxN} - 1 st V _{DAC}	--	-100	--	mV
VR_RDY Low Voltage	V _{VR_RDY}	I _{VR_RDY} = 4mA	--	--	0.4	V
VR_RDY Delay	t _{VR_RDY}	V _{ISENxN} = V _{INITIAL} to VR_RDY High	--	100	--	μs

Parameter	Symbol	Test Conditions	Min	Typ	Max	Unit	
Thermal Throttling							
VRHOT Output Voltage	V_{VRHOT}	$I_{VRHOT} = 10\text{mA}$	--	--	0.13	V	
Current Monitor							
Current Monitor Maximum Output Voltage in Operating Range	V_{IMON}	$V_{DAC} = 1\text{V}$, $V_{FB} - V_{CC_SENSE} = 100\text{mV}$, $R_{IMONFB} = 10\text{k}\Omega$, $R_{IMON} = 330\text{k}\Omega$	3.2	3.3	3.4	V	
High Impedance Output							
PWMx, ALERT, VRx_RDY, VRHOT	I_{LEAK_OUT}		-1	--	1	μA	
PWM Driving Capability							
PWM Source Resistor	R_{PWM_SOURCE}		--	30	--	Ω	
PWM Sink Resistor	R_{PWM_SINK}		--	15	--	Ω	
DVID, DVIDA, ICCMAX, ICCMAXA, and TMPMAX Pin Current							
Current Sourcing Out from DVIDx Pin to GND	I_{DVIDx}	During dynamic VID fast event	6	8	10	μA	
Current Sinking In from 5V to ICCMAX Pin	I_{ICCMAX}	After VR_RDY	--	16	--	μA	
Current Sourcing Out from ICCMAXA Pin to GND	$I_{ICCMAXA}$	After VRA_RDY	--	128	--	μA	
Current Sinking In from 5V to TMPMAX Pin	I_{TMPMAX}	After VR_RDY	--	16	--	μA	
DVID and DVIDA Maximum Voltage							
Maximum Allowable Voltage at DVIDx Pin	V_{DVIDx_MAX}	During Dynamic VID Event	--	--	2	V	
SVID							
SVID Frequency	f_{SVID}		5	25	26.25	MHz	
SVID Clock to Data Delay	t_{CO}		4	--	8.3	ns	
Setup Time of VDIO	t_{SU}		7	--	--	ns	
Hold Time of VDIO	t_{HLD}		14	--	--	ns	
V_{INITIAL} Setting							
SETINIx Threshold Voltage	$V_{SETINIO}$	For $V_{INITIAL} = 0\text{V}$	0	--	8	%V _{CC}	
	$V_{SETINIO_9}$	For $V_{INITIAL} = 0.9\text{V}$	17	--	20		
	$V_{SETINI1_0}$	For $V_{INITIAL} = 1\text{V}$	32.5	--	42.5		
	$V_{SETINI1_1}$	For $V_{INITIAL} = 1.1\text{V}$	57.5	--	67.5		
	$V_{SETINI1_5}$	For $V_{INITIAL} = 1.5\text{V}$	82.5	--	100		
ADD Threshold							
ADD Input Threshold Voltage	Logic-Low	V_{IL}	Set SVID address 0000 0001	--	--	0.35	V
	Logic-Medium	V_{IM}	Set SVID address 0010 0011	0.7	--	3	
	Logic-High	V_{IH}	Set SVID address 0100 0101	$V_{CC} - 0.2$	--	--	

Parameter	Symbol	Test Conditions	Min	Typ	Max	Unit
ADC						
Digital Code of ICCMAX	C _{ICCMAX1}	V _{ICCMAX} = 12.74%V _{CC}	29	32	35	decimal
	C _{ICCMAX2}	V _{ICCMAX} = 25.284%V _{CC}	61	64	67	
	C _{ICCMAX3}	V _{ICCMAX} = 50.372%V _{CC}	125	128	131	
Digital Code of ICCMAXA	C _{ICCMAXA1}	V _{ICCMAX} = 3.332%V _{CC}	5	8	11	decimal
	C _{ICCMAXA2}	V _{ICCMAX} = 6.468%V _{CC}	13	16	19	
	C _{ICCMAXA3}	V _{ICCMAX} = 12.74%V _{CC}	29	32	35	
Digital Code of TMPMAX	C _{TMPMAX1}	V _{ICCMAX} = 33.516%V _{CC}	82	85	88	decimal
	C _{TMPMAX2}	V _{ICCMAX} = 39.396%V _{CC}	97	100	103	
	C _{TMPMAX3}	V _{ICCMAX} = 49.196%V _{CC}	122	125	128	
Digital Code of Output Current Report	C _{OOCR1}	V _{IMON(A)} = 3.3V	252	255	255	decimal
	C _{OOCR2}	V _{IMON(A)} = 2.208V	167	170	173	
	C _{OOCR3}	V _{IMON(A)} = 1.107V	82	85	88	
Updating Period of Output Current Report	t _{OOCR}		--	--	500	μs
Tolerance Band of Temperature_Zone Trip Points b7, b6, b5	V _{TSEN}		20	--	20	mV
Updating Period of Temperature_Zone	t _{TZ}		--	--	4	ms

Note 1. Stresses beyond those listed “Absolute Maximum Ratings” may cause permanent damage to the device. These are stress ratings only, and functional operation of the device at these or any other conditions beyond those indicated in the operational sections of the specifications is not implied. Exposure to absolute maximum rating conditions may affect device reliability.

Note 2. θ_{JA} is measured at T_A = 25°C on a high effective thermal conductivity four-layer test board per JEDEC 51-7. θ_{JC} is measured at the exposed pad of the package.

Note 3. Devices are ESD sensitive. Handling precaution is recommended.

Note 4. The device is not guaranteed to function outside its operating conditions.

Typical Operating Characteristics

CORE VR Power On

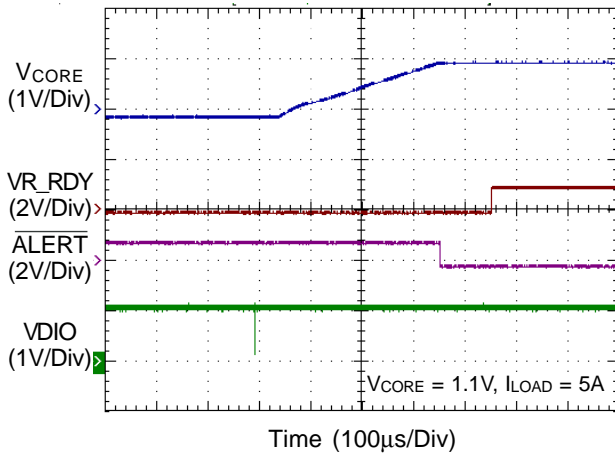

CORE VR Power Off from EN

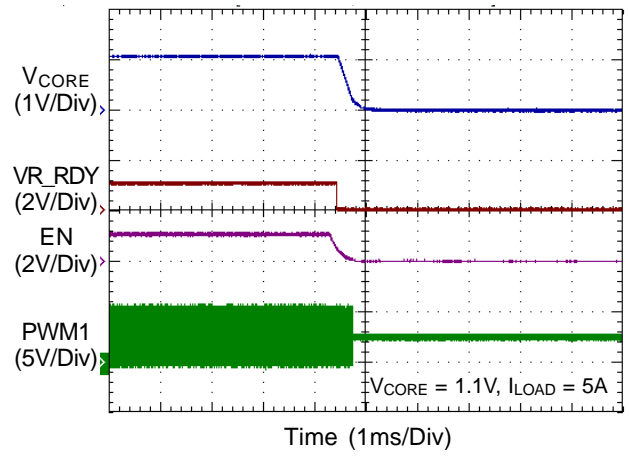

CORE VR Dynamic VID Up

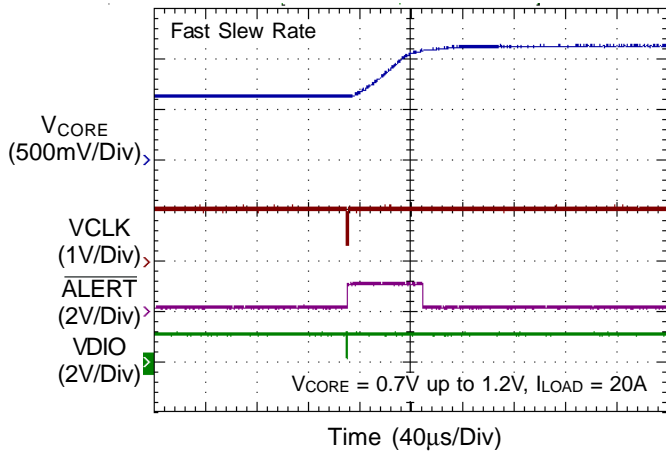

CORE VR Dynamic VID Up

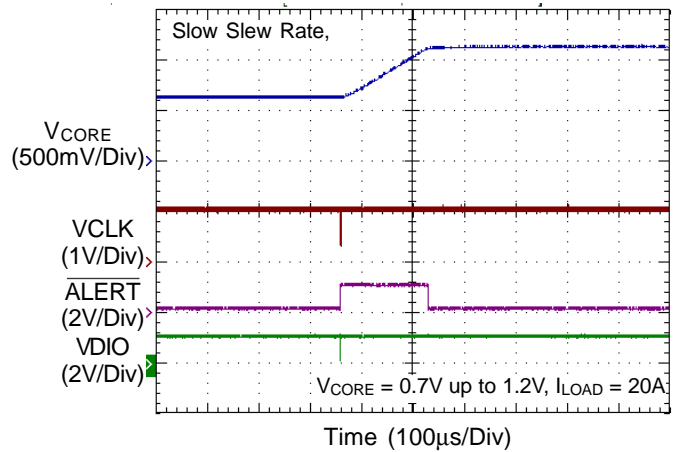

CORE VR Dynamic VID Down

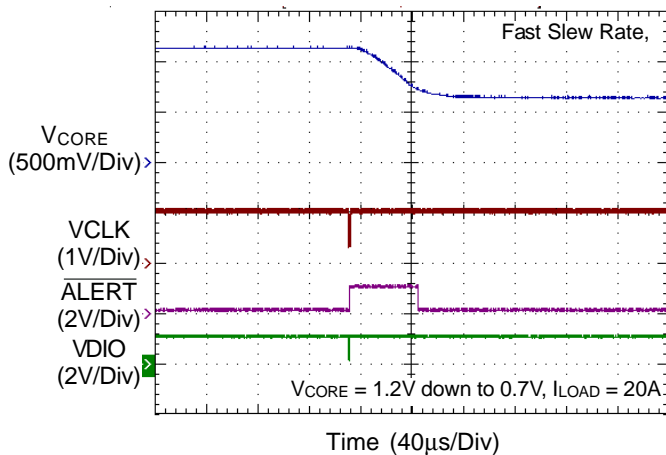

CORE VR Dynamic VID Down

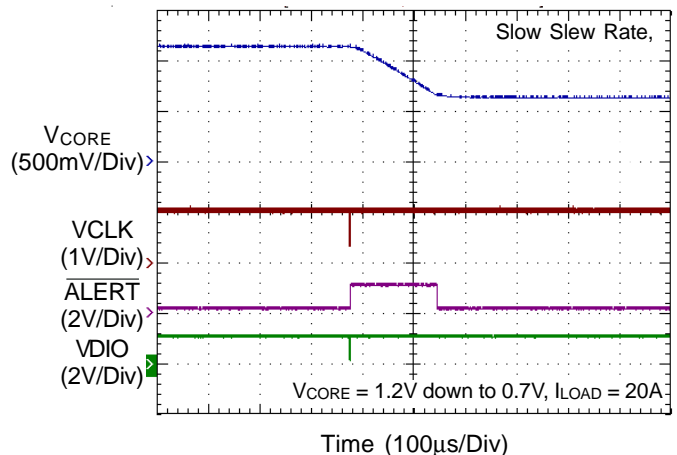

CORE VR Load Transient Response

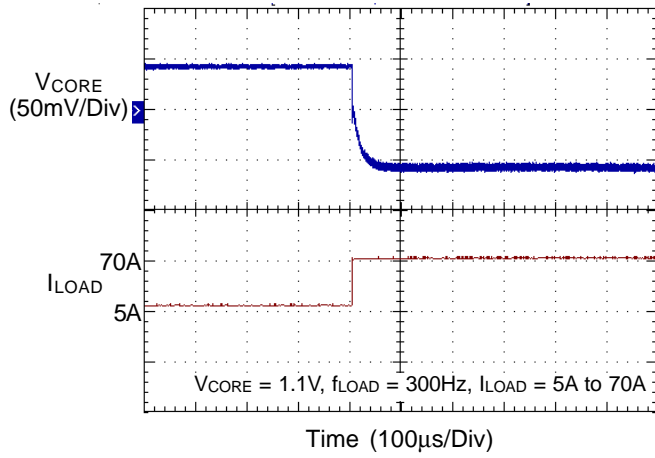

CORE VR Load Transient Response

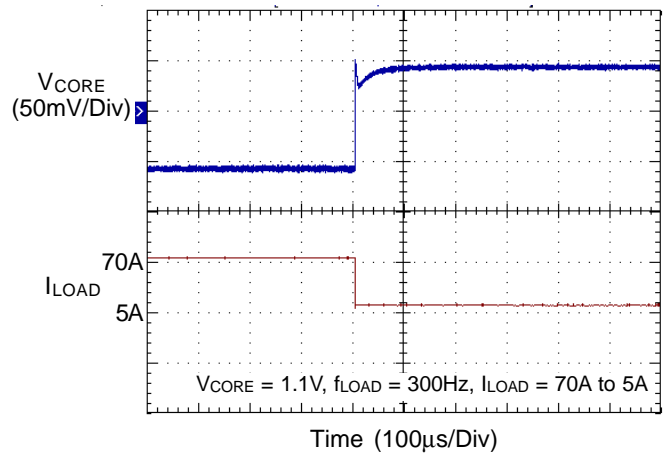

CORE VR OCP

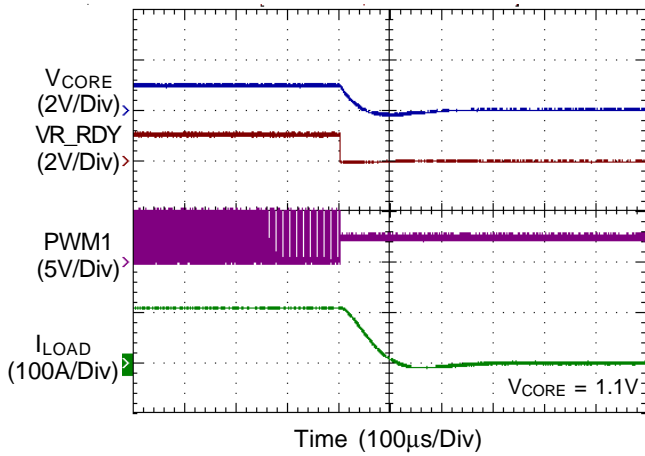

CORE VR OVP & NVP

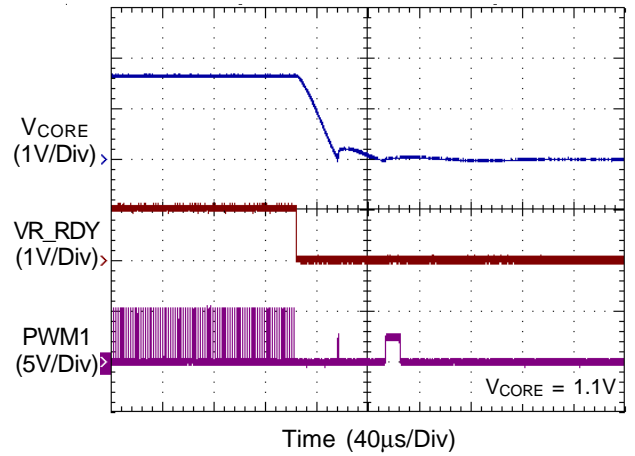

CORE VR UVP

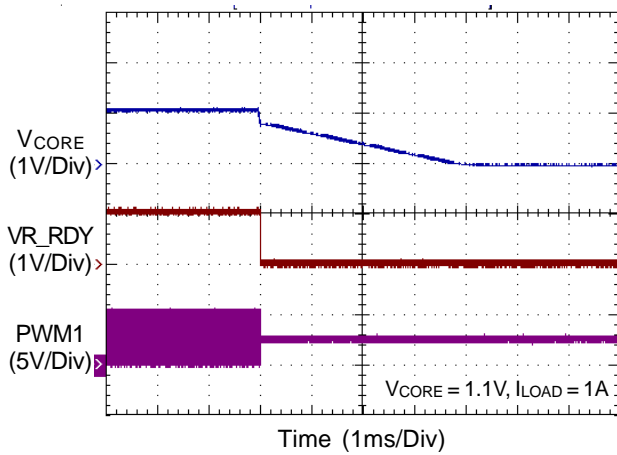

V_{MON} vs. Load Current

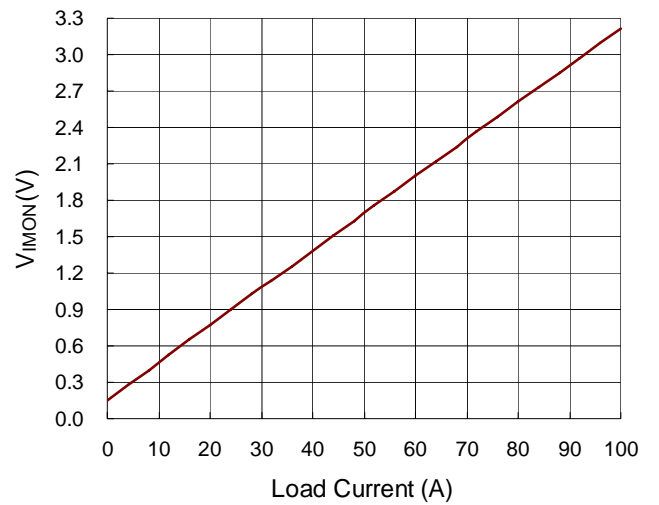

AXG VR Power On

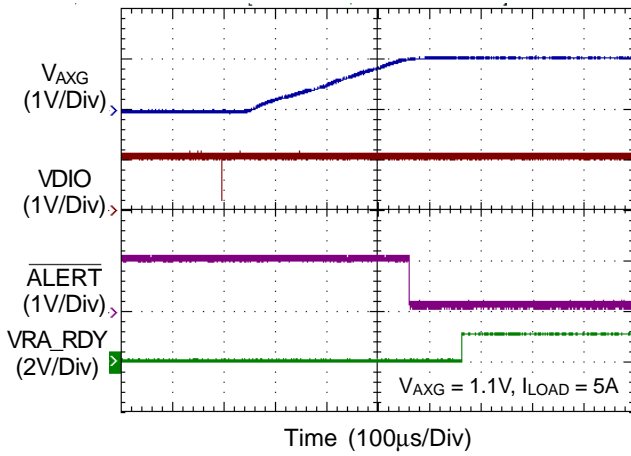

AXG VR Power Off from EN

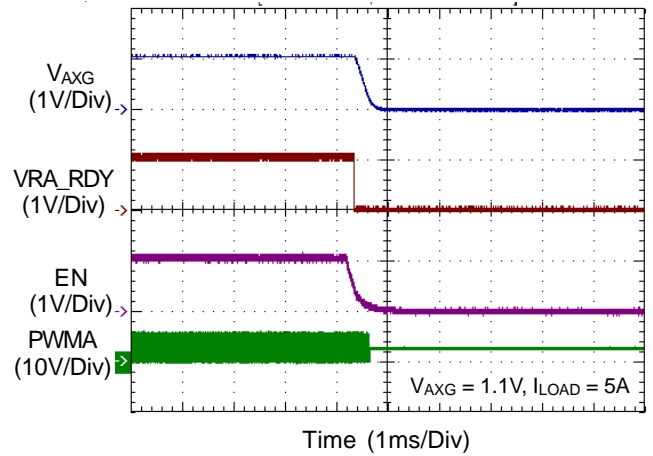

AXG VR Dynamic VID Up

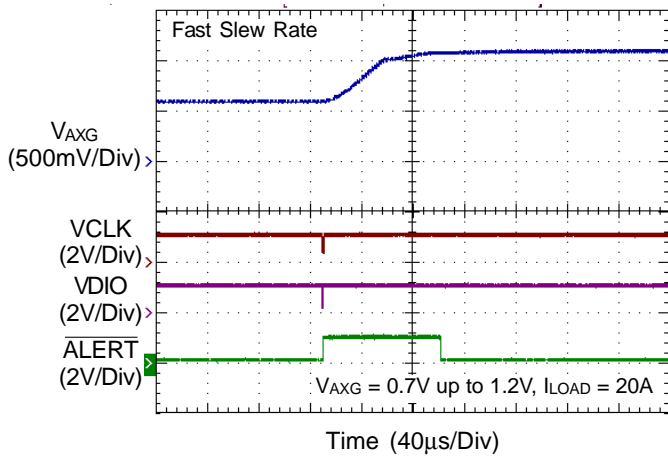

AXG VR Dynamic VID Up

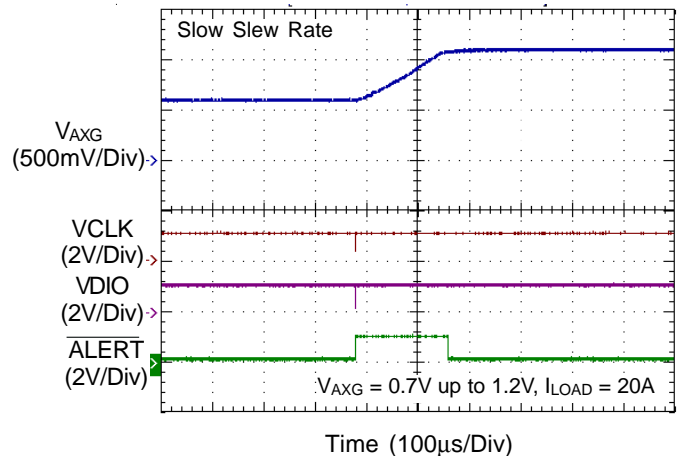

AXG VR Dynamic VID Down

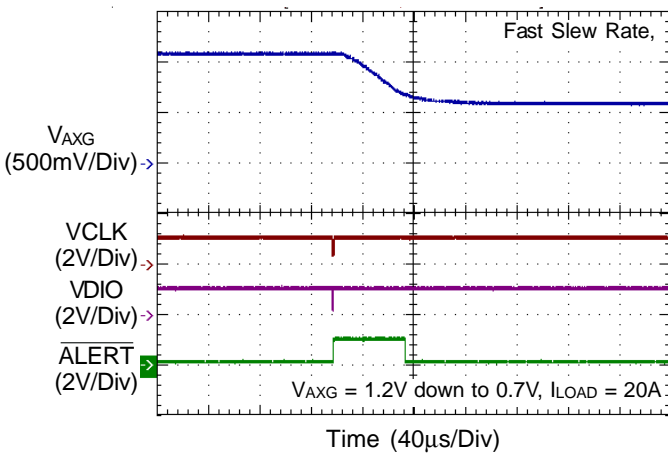

AXG VR Dynamic VID Down

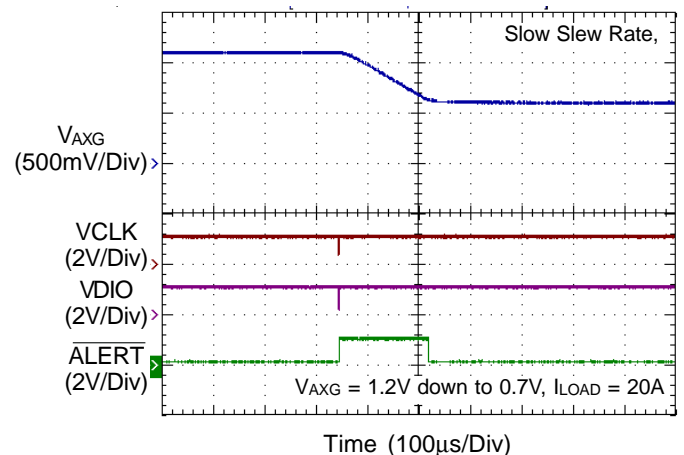

AXG VR Load Transient Response

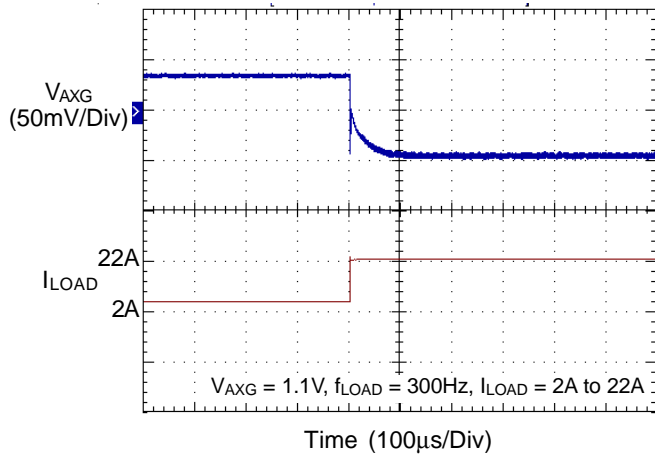

AXG VR Load Transient Response

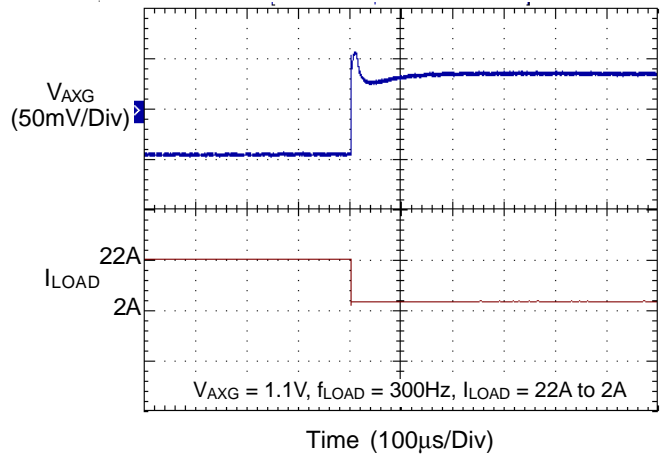

AXG VR OCP

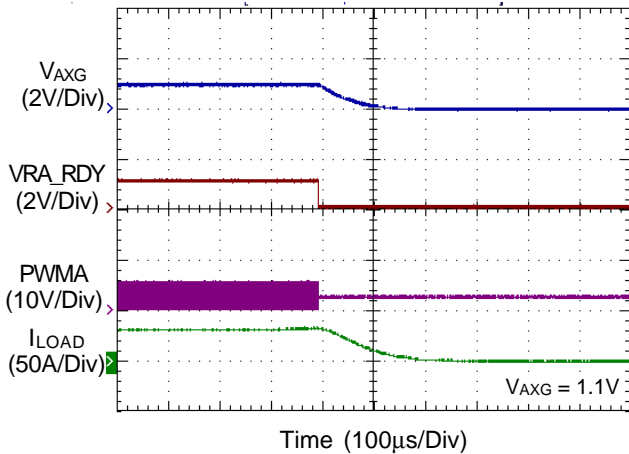

AXG VR OVP & NVP

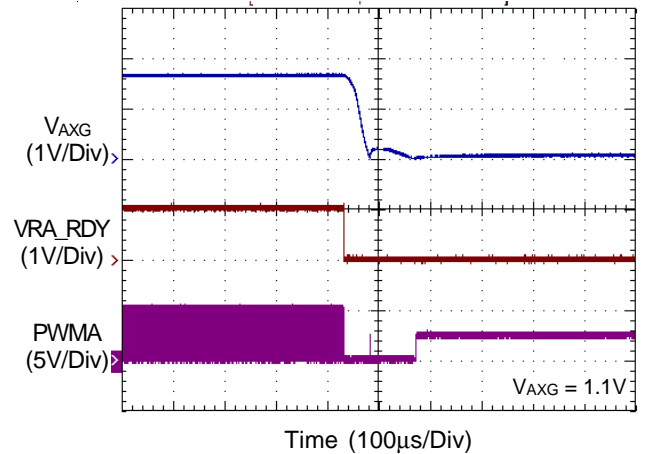

AXG VR UVP

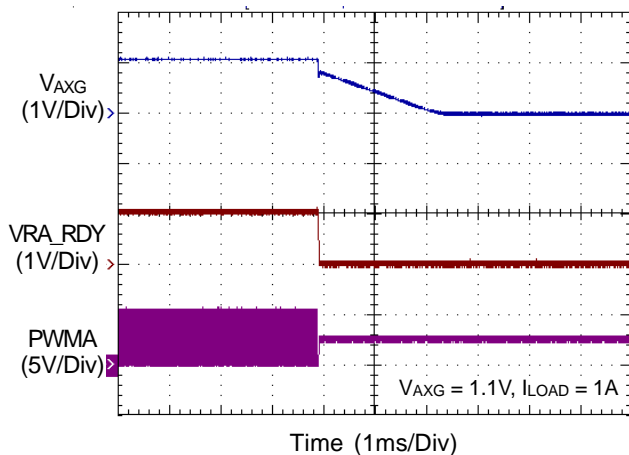

V_{IMONA} vs. Load Current

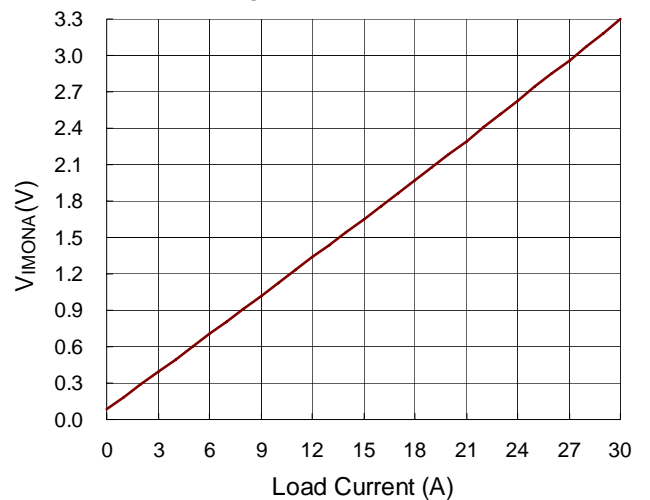

Thermal Monitoring

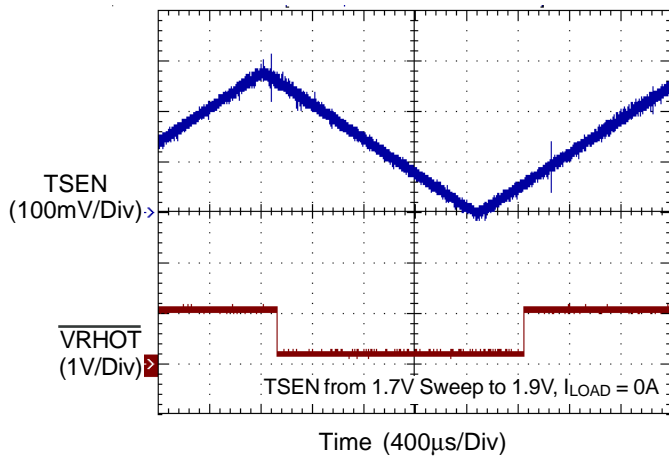

Application Information

The RT8859M is a CPU power controller which includes two voltage rails : a 4/3/2/1 phase synchronous buck controller, the CORE VR, and a single phase buck controller, the AXG VR. The RT8859M is compliant with Intel VR12/IMVP7 voltage regulator specification to fulfill Intel's CPU power supply requirements of both CORE and AXG voltage rails. A Serial VID (SVID) interface is built-in in the RT8859M to communicate with Intel VR12/IMVP7 compliant CPU.

The RT8859M adopts G-NAVP™ (Green Native AVP), which is Richtek's proprietary topology derived from finite DC gain compensator with current mode control, making it an easy setting PWM controller, meeting all Intel CPU requirements of AVP (Active Voltage Positioning). The load line can be easily programmed by setting the DC gain of the error amplifier. The RT8859M has fast transient response due to the G-NAVP™ commanding variable switching frequency. Based on the G-NAVP™ topology, the RT8859M also features a quick response mechanism for optimized AVP performance during load transient.

The G-NAVP™ topology also represents a high efficiency system with green power concept. With the G-NAVP™ topology, the RT8859M becomes a green power controller with high efficiency under heavy load, light load, and very light load conditions. The RT8859M supports mode transition function with various operating states, including multi-phase, single phase and diode emulation modes. These different operating states allow the overall power control system to have the lowest power loss. By utilizing the G-NAVP™ topology, the operating frequency of the RT8859M varies with VID, load, and input voltage to further enhance the efficiency even in CCM.

The built-in high accuracy DAC converts the SVID code ranging from 0.25V to 1.52V with 5mV per step. The RT8859M supports VID on-the-fly function with three different slew rates : Fast, Slow and Decay. The RT8859M also builds in a high accuracy ADC for some platform setting functions, such as no-load offset or over-current level. The controller supports both DCR and sense resistor current sensing. The RT8859M provides power VR ready signals for both CORE VR and AXG VR. It also features

complete fault protection functions including over voltage, under voltage, negative voltage, over current and under voltage lockout. The RT8859M is available in a WQFN-56L 7x7 small footprint package.

General Loop Functions

VR Rail Addressing and Slew rate Setting

The voltage level at the ADD pin defines the VR addresses of the RT8859M. User can also flip the VR address by properly setting the voltage on SR_ADDDF pin. There are three valid voltage levels for ADD pin : VCC (5V), floating, and GND. Connecting the ADD pin to one of these three voltage levels can set the addresses of both CORE VR and AXG VR according to the following table. The All Call address, 1111, 1110, can only be used with SetVID or SetPS commands.

Address Flip	ADD Level	VR1 (CORE) Address	VR1 (AXG) Address
No	VCC	0100	0101
	Floating	0010	0011
	GND	0000	0001
Yes	VCC	0101	0100
	Floating	0011	0010
	GND	0001	0000

The RT8859M can also program the dynamic VID slew rate by setting the SR_ADDDF pin. After POR, the RT8859M will detect the voltage level on the SR_ADDDF pin and latch the status of the address and the dynamic VID slew rate. Below is the setting table of SR_ADDDF. The recommended voltage tolerance is (recommended voltage $\pm 25\text{mV}$). Make sure the voltage divider at SR_ADDDF pin uses the same VCC as pin 41 (VCC).

Recommended SR_ADDF Voltage (if V _{CC} = 5V)	Address Flipped	VR0 Fast Slew Rate (mV/μs)	VR0 Slow Slew Rate (mV/μs)	VR1 Fast Slew Rate (mV/μs)	VR1 Slow Slew Rate (mV/μs)
5	Yes	10	2.5	10	2.5
4.766	Yes	10	2.5	10	5
4.609	Yes	10	5	10	2.5
4.453	Yes	10	5	10	5
4.297	Yes	15	3.75	10	2.5
4.141	Yes	15	3.75	10	5
3.984	Yes	15	7.5	10	2.5
3.828	Yes	15	7.5	10	5
3.672	Yes	20	5	10	2.5
1.797	No	20	10	10	5
1.641	No	20	10	10	2.5
1.484	No	20	5	10	5
1.328	No	20	5	10	2.5
1.172	No	15	7.5	10	5
1.016	No	15	7.5	10	2.5
0.859	No	15	3.75	10	5
0.703	No	15	3.75	10	2.5
0.547	No	10	5	10	5
0.391	No	10	5	10	2.5
0.234	No	10	2.5	10	5
0	No	10	2.5	10	2.5

Power Ready (POR) Detection

During start-up, the RT8859M will detect the voltage at the voltage input pins : VCC, EN, DVD and DVDA. When $V_{CC} > 4.24V$, $V_{DVD} > 1.06V$ and $V_{DVDA} > 1.06V$, the RT8859M will recognize the power state of system to be ready (POR = high) and wait for enable command at the EN pin. After POR = high and $V_{EN} > 0.7V$, the RT8859M will enter start-up sequence for both CORE rail and AXG rail. If the voltage at any voltage pin drops below low threshold (POR = low), the RT8859M will enter power down sequence and all the functions will be disabled. Normally, connecting system V_{TT} (1.05V) to the EN pin and power stage V_{IN} (12V, through a voltage divider) to the DVD pin is recommended. 2ms (max) after the chip has been enabled, the SVID circuitry will be ready. All the protection latches (OVP, OCP, UVP) will be cleared only after POR = low. The condition of $V_{EN} = \text{low}$ will not clear these latches.

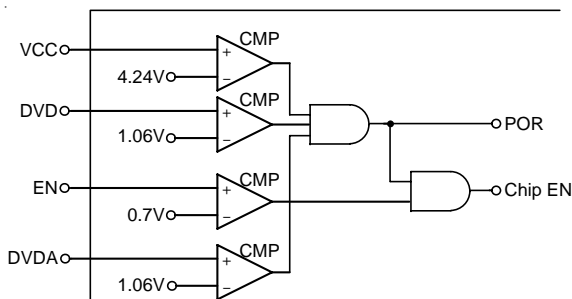

Figure 1. Power Ready (POR) Detection

Precise Reference Current Generation

The RT8859M includes complicated analog circuits inside the controller. These analog circuits need very precise reference voltage/current to drive these analog devices. The RT8859M will auto generate a 2.14V voltage source at the IBIAS pin, and a 53.6kΩ resistor is required to be connected between IBIAS and analog ground. Through this connection, the RT8859M will generate a 40μA current from the IBIAS pin to analog ground, and this 40μA current will be mirrored inside the RT8859M for internal use. Note that other types of connection or other values of resistance applied at the IBIAS pin may cause failure of the RT8859M's functions, such as slew rate control, OFS accuracy, etc. In other words, the IBIAS pin can only be connected with a 53.6kΩ resistor to GND. The resistance accuracy of this resistor is recommended to be 1% or higher.

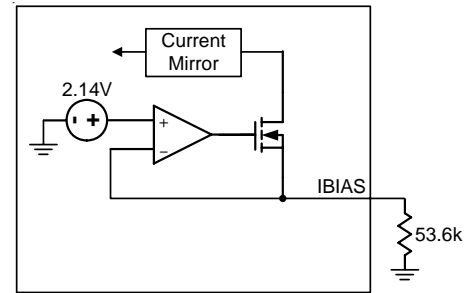

Figure 2. IBIAS Setting

ICCMAX, ICCMAXA and TMPMAX

The RT8859M provides ICCMAX, ICCMAXA and TMPMAX pins for platform users to set the maximum level of output current or VR temperature : ICCMAX for CORE VR max current, ICCMAXA for AXG VR max current, and TMPMAX for CORE VR max temperature.

To set ICCMAX, ICCMAXA and TMPMAX, platform designers should use resistive voltage divider on these three pins. The current of the divider should be several milliamps to avoid noise effect. The 3 items share the same algorithms : the ADC divides 5V into 255 levels. Therefore, the LSB = $5 / 255 = 19.6mV$, which means 19.6mV applied to ICCMAX pin equals to 1A setting. For example, if the maximum level of temperature is desired to be 120°C, the voltage applied to TMPMAX should be $120 \times 19.6mV = 2.352V$. The ADC circuit inside these three pins will decode the voltage applied and store the maximum current/temperature setting into ICC_Max and Temp_Max registers. The ADC monitors and decodes the voltage at these three pins only ONCE after power up. After ADC decoding (only once), a 128μA current will be generated at the ICCMAXA pin for internal use. Make sure the voltage at the ICCMAXA pin is greater than 1.55V to guarantee proper functionality.

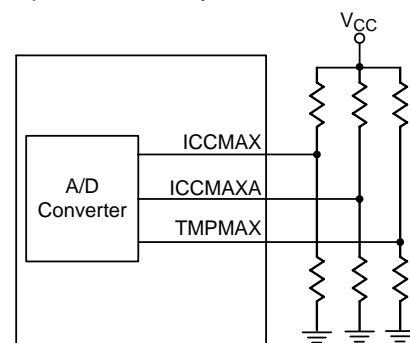

Figure 3. ADC Pins Setting

The RT8859M will NOT take any action even when the VR output current or temperature exceeds its maximum setting at these ADC pins. The maximum level settings at these ADC pins are different from over current protection or over temperature protection. In other words, these maximum level setting pins are only for platform users to define their system operating conditions and these messages will only be utilized by the CPU.

V_{INITIAL} Setting

The initial startup voltage of the RT8859M can be set by platform users through the SETINI and the SETINIA pins. Voltage divider circuits are recommended to be applied to the SETINI and the SETINIA pins. The initial startup voltage relates to the SETINI pin voltage setting as shown in Table 4. Recommended voltage setting at the SETINIA pin is also shown in Table 4.

Table 4. SETINI (SETINIA) Pin Setting

Initial Startup Voltage	Recommended SETINI Pin Voltage
1.5V	$\frac{7}{8} \times VCC \approx 4.375V$
1.1V	$\frac{5}{8} \times VCC \approx 3.125V$
1V	$\frac{3}{8} \times VCC \approx 1.875V$
0.9V	$\frac{3}{16} \times VCC \approx 0.9375V$
0V	$\frac{1}{16} \times VCC \approx 0.3125V$ or GND

Start-Up Sequence

The RT8859M utilizes an internal soft-start sequence which strictly follows Intel VR12/IMVP7 start-up sequence specifications. After POR = high and EN = high, the controller considers all the power inputs ready and enters start-up sequence. If V_{INITIAL} = 0, V_{OUT} is programmed to stay at 0V for 2ms waiting for SVID command. If V_{INITIAL} ≠ 0, V_{OUT} will ramp up to V_{INITIAL} voltage (which is not zero) immediately after both POR = high and EN= high. After V_{OUT} reaches target V_{INITIAL}, V_{OUT} will stay at V_{INITIAL} waiting for SVID command. After the RT8859M receives valid VID code (typically SetVID_Slow command), V_{OUT} will ramp up to the target voltage with specified slew rate (see section “Data and Configuration Register”). After V_{OUT} reaches target voltage (VID voltage for V_{INITIAL} = 0 or V_{INITIAL} for V_{INITIAL} ≠ 0), the RT8859M will send out VR_RDY signal to indicate that the power state of the RT8859M is ready. The VR ready circuit is an open-drain structure, so a pull-up resistor connected to a voltage source is recommended.

Power Down Sequence

Similar to the start-up sequence, the RT8859M also utilizes a soft shutdown mechanism during turn-off. After EN = low, the internal reference voltage (positive terminal of compensation EA) starts ramping down with 3.125mV/μs slew rate, and V_{OUT} will follow the reference voltage to 0V. After V_{OUT} drops below 0.2V, the RT8859M shuts down and all functions (drivers) are disabled. The VR_RDY and VRA_RDY will be pulled down immediately after POR = low or EN = low.

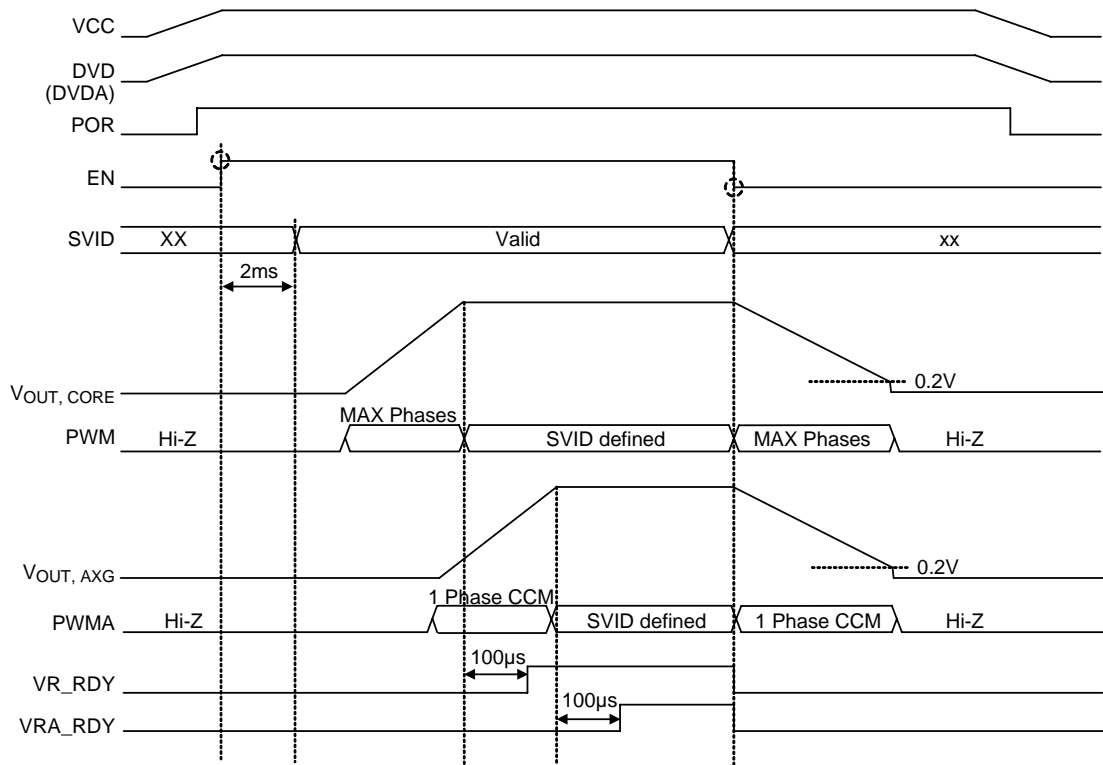

Figure 4 (a). Power Sequence for the RT8859M ($V_{INITIAL} = V_{INITIALA} = 0V$)

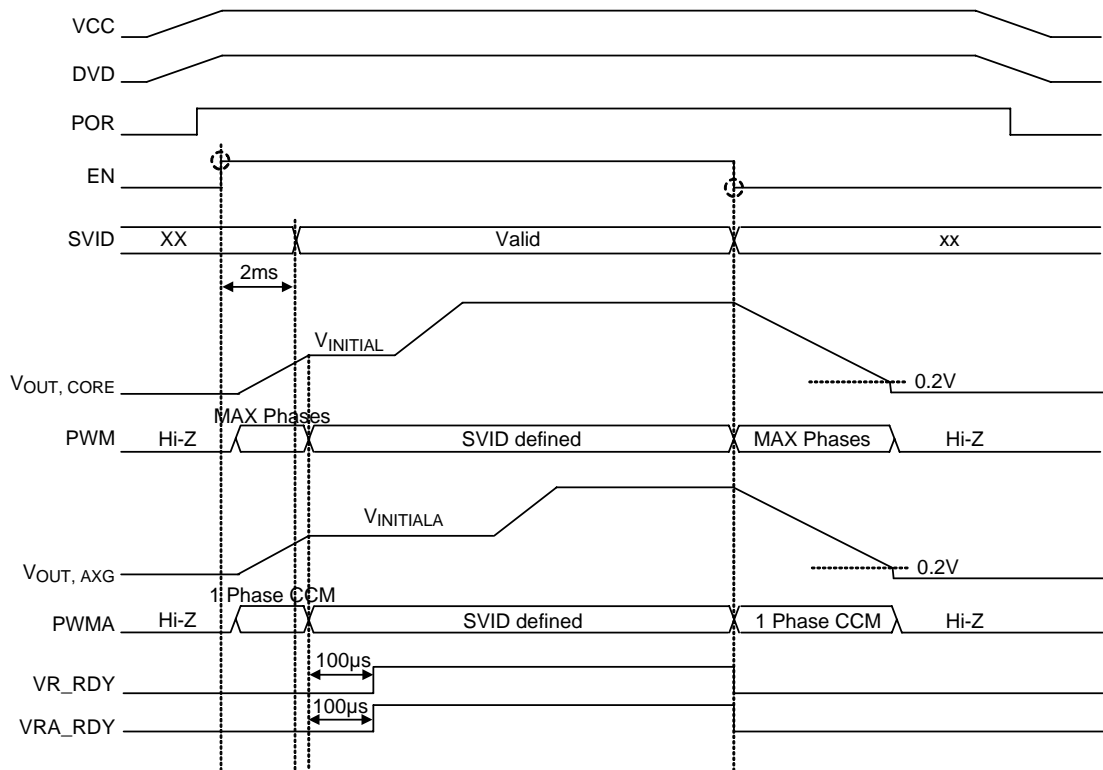

Figure 4 (b). Power Sequence for the RT8859M ($V_{INITIAL} \neq 0V, V_{INITIALA} \neq 0V$)

CORE VR

Active Phase Determination : Before POR

The number of active phases is determined by the internal circuitry that monitors the ISENxN voltages during start-up. Normally, the CORE VR operates as a 4-phase PWM controller. Pulling ISEN4N to VCC programs a 3-phase operation, pulling ISEN3N and ISEN4N to VCC programs a 2-phase operation, and pulling ISEN2N, ISEN3N and ISEN4N to VCC programs a 1-phase operation. Before POR, CORE VR detects whether the voltages of ISEN2N, ISEN3N and ISEN4N are higher than “V_{CC} – 1V” respectively to decide how many phases should be active. Phase selection is only active during POR. When POR = high, the number of active phases is determined and latched. The unused ISENxP pins are recommended to be connected to VCC and unused PWM pins can be left floating.

Loop Control

The CORE VR adopts Richtek’s proprietary G-NAVP™ topology. G-NAVP™ is based on the finite gain peak current mode with CCRCOT (Constant Current Ripple Constant On-Time) topology. The output voltage, V_{OUT, CORE}, will decrease with increasing output load current. The control loop consists of PWM modulators with power stages, current sense amplifiers and an error amplifier as shown in Figure 5.

Similar to the peak current mode control with finite compensator gain, the HS_FET on-time is determined by CCRCOT on-time generator. When load current increases, V_{CS} increases, the steady state COMP voltage also increases and induces V_{OUT, CORE} to decrease, thus achieving AVP. A near-DC offset canceling is added to the output of EA to eliminate the inherent output offset of finite gain peak current mode controller.

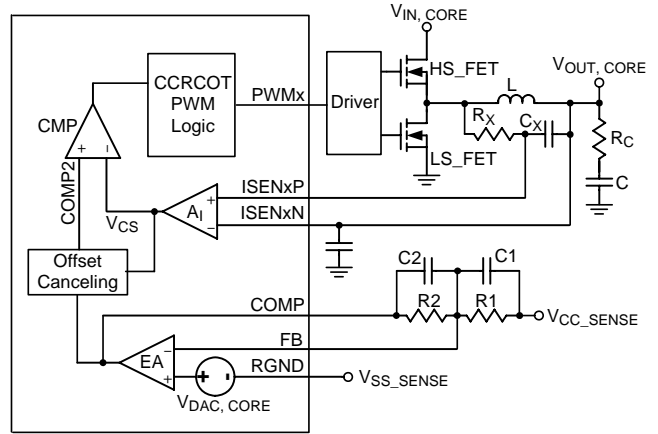

Figure 5. CORE VR : Simplified Schematic for Droop and Remote Sense in CCM

Droop Setting (with Temperature Compensation)

It’s very easy to achieve Active Voltage Positioning (AVP) by properly setting the error amplifier gain due to the native droop characteristics. The target is to have

$$V_{OUT} = V_{DAC} - I_{LOAD} \times R_{DROOP} \tag{1}$$

Then solving the switching condition V_{COMP2} = V_{CS} in Figure 5 yields the desired error amplifier gain as

$$A_V = \frac{R_2}{R_1} = \frac{A_I \times R_{SENSE}}{R_{DROOP}} \tag{2}$$

where A_I is the internal current sense amplifier gain. R_{SENSE} is the current sense resistor. If no external sense resistor present, it is the DCR of the inductor. R_{DROOP} is the equivalent load line resistance as well as the desired static output impedance.

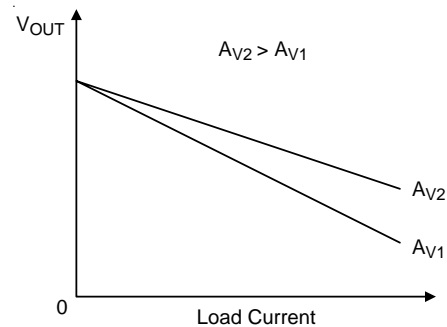

Figure 6. CORE VR : Error Amplifier gain (A_V) Influence on V_{OUT} Accuracy

Since the DCR of the inductor is temperature dependent, it affects the output accuracy at hot conditions. Temperature compensation is recommended for the lossless inductor DCR current sense method. Figure 7 shows a simple but effective way of compensating the

temperature variations of the sense resistor using an NTC thermistor placed in the feedback path.

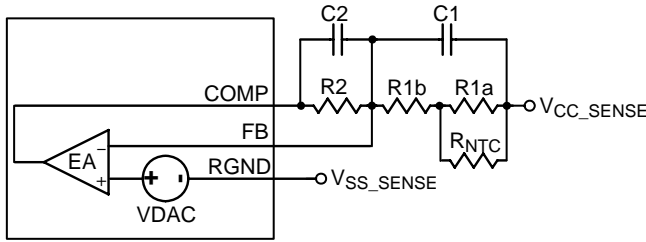

Figure 7. CORE VR : Loop Setting with Temperature Compensation

Usually, R1a is set to equal R_{NTC} (25°C). R1b is selected to linearize the NTC's temperature characteristic. For a given NTC, design is to get R1b and R2 and then C1 and C2. According to equation (2), to compensate the temperature variations of the sense resistor, the error amplifier gain (A_V) should have the same temperature coefficient with R_{SENSE}. Hence

$$\frac{A_{V, HOT}}{A_{V, COLD}} = \frac{R_{SENSE, HOT}}{R_{SENSE, COLD}} \quad (3)$$

From equation (2), A_V can be obtained at any temperature (T°C) as shown below :

$$A_{V, T^{\circ}C} = \frac{R2}{R1a // R_{NTC, T^{\circ}C} + R1b} \quad (4)$$

The standard formula for the resistance of NTC thermistor as a function of temperature is given by :

$$R_{NTC, T^{\circ}C} = R_{25^{\circ}C} e^{\left\{ \beta \left[\left(\frac{1}{T+273} \right) - \left(\frac{1}{298} \right) \right] \right\}} \quad (5)$$

Where R_{25°C} is the thermistor's nominal resistance at room temperature, β is the thermistor's material constant in Kelvins, and T is the thermistor's actual temperature in Celsius.

To calculate DCR value at different temperature can use the equation as below :

$$DCR_{T^{\circ}C} = DCR_{25^{\circ}C} \times [1 + 0.00393 \times (T - 25)] \quad (6)$$

where 0.00393 is the temperature coefficient of copper. For a given NTC thermistor, solving equation (4) at room temperature (25°C) yields :

$$R2 = A_{V, 25^{\circ}C} \times (R1b + R1a // R_{NTC, 25^{\circ}C}) \quad (7)$$

where A_{V, 25°C} is the error amplifier gain at room temperature and can be obtained from equation (2). R_{1b} can be obtained by substituting (7) to (3),

R1b =

$$\frac{R_{SENSE, HOT}}{R_{SENSE, COLD}} \times (R1a // R_{NTC, HOT}) - (R1a // R_{NTC, COLD}) \left(1 - \frac{R_{SENSE, HOT}}{R_{SENSE, COLD}} \right) \quad (8)$$

Droop Disable

The CORE VR's droop function can be enabled or disabled with different connections of the QRSET pin. The connection of the QRSET pin is usually a voltage divider circuit which is described later in the Quick Response section. Before POR, the RT8859M will source 80μA current from the QRSET pin to the external voltage divider to determine the voltage level while the RT8859M is still not powered on. Before POR, if the voltage at the QRSET pin is higher than V_{CC} - 0.5V, the CORE VR will operate in droop enabled mode. If the voltage is lower than V_{CC} - 1.8V, the CORE VR will operate without droop function, which means at the DC level of DAC voltage. For example, a 5V voltage divided by two 1kΩ resistors connected to the QRSET pin generates 2.54V (5V/2 + 80μA x 1kΩ/2) before POR and 2.5V (5V/2) after POR.

Loop Compensation

Optimized compensation of the CORE VR allows for best possible load step response of the regulator's output. A type-I compensator with one pole and one zero is adequate for proper compensation. Figure 8 shows the compensation circuit. Prior design procedure shows how to select the resistive feedback components for the error amplifier gain. Next, C1 and C2 must be calculated for the compensation. The target is to achieve constant resistive output impedance over the widest possible frequency range.

The pole frequency of the compensator must be set to compensate the output capacitor ESR zero :

$$f_p = \frac{1}{2 \times \pi \times C \times R_C} \quad (9)$$

Where C is the capacitance of output capacitor, and R_C is the ESR of output capacitor. C2 can be calculated as follows :

$$C2 = \frac{C \times R_C}{R2} \quad (10)$$

The zero of compensator has to be placed at half of the switching frequency to filter the switching related noise. Such that,

$$C1 = \frac{1}{(R1b + R1a // R_{NTC, 25^{\circ}C}) \times \pi \times f_{SW}} \quad (11)$$

TON Setting

High frequency operation optimizes the application for the smaller component size, trading off efficiency due to higher switching losses. This may be acceptable in ultra portable devices where the load currents are lower and the controller is powered from a lower voltage supply. Low frequency operation offers the best overall efficiency at the expense of component size and board space. Figure 8 shows the On-Time setting Circuit. Connect a resistor (R_{TON}) between V_{IN,CORE} and TONSET to set the on-time of UGATE :

$$t_{ON} (V_{DAC} < 1.2V) = \frac{24.4 \times 10^{-12} \times R_{TON}}{V_{IN} - V_{DAC}} \quad (12)$$

where t_{ON} is the UGATE turn on period, V_{IN} is Input voltage of the CORE VR, and V_{DAC} is the DAC voltage.

When VDAC is larger than 1.2V, the equivalent switching frequency may be over 500kHz, and this too fast switching frequency is unacceptable. Therefore, the CORE VR implements a pseudo constant frequency technology to avoid this disadvantage of CCRCOT topology. When VDAC is larger than 1.2V, the on-time equation will be modified to :

$$t_{ON} (V_{DAC} \geq 1.2V) = \frac{20.33 \times 10^{-12} \times R_{TON} \times V_{DAC}}{V_{IN} - V_{DAC}} \quad (13)$$

During PS2/PS3 operation, the CORE VR shrinks its on-time for the purpose of reducing output voltage ripple caused by DCM operation. The shrink percentage is 15% compared with original on-time setting by equation (12) or (13). That is, after setting the PS0 operation on-time, the PS2/PS3 operation on-time is 0.85 times the original on-time.

On-time translates only roughly to switching frequencies. The on-times guaranteed in the Electrical Characteristics are influenced by switching delays in external HS-FET. Also, the dead-time effect increases the effective on-time, which in turn reduces the switching frequency. It occurs only in CCM and during dynamic output voltage transitions

when the inductor current reverses at light or negative load currents. With reversed inductor current, the phase goes high earlier than normal, extending the on-time by a period equal to the HS-FET rising dead time.

For better efficiency of the given load range, the maximum switching frequency is suggested to be :

$$f_{S(MAX)}(kHz) = \frac{1}{T_{ON} - T_{HS-Delay}} \times \frac{V_{DAC(MAX)} + I_{LOAD(MAX)} \times [R_{ON_LS-FET} + DCR - R_{DROOP}]}{V_{IN(MAX)} + I_{LOAD(MAX)} \times [R_{ON_LS-FET} - R_{ON_HS-FET}]} \quad (14)$$

Where f_{S(MAX)} is the maximum switching frequency, t_{HS-DELAY} is the turn-on delay of HS-FET, V_{DAC(MAX)} is the Maximum VDAC of application, V_{IN(MAX)} is the Maximum application Input voltage, I_{LOAD(MAX)} is the maximum load of application, R_{ON,LS-FET} is the Low side FET R_{DS(ON)}, R_{ON,HS-FET} is the High side FET R_{DS(ON)}, DCR_L is the inductor DCR, and R_{DROOP} is the load line setting.

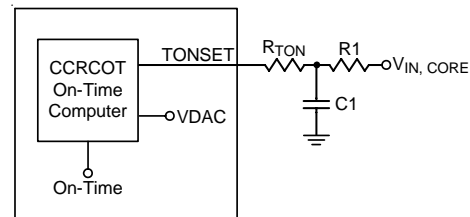

Figure 8. CORE VR : On-Time Setting with R_C Filter

Differential Remote Sense Setting

The CORE VR includes differential, remote-sense inputs to eliminate the effects of voltage drops along the PC board traces, CPU internal power routes and socket contacts. The CPU contains on-die sense pins, V_{CC_SENSE} and V_{SS_SENSE}. Connect RGND to V_{SS_SENSE}. Connect FB to V_{CC_SENSE} with a resistor to build the negative input path of the error amplifier. The VDAC and the precision voltage reference are referred to RGND for accurate remote sensing.

Current Sense Setting

The current sense topology of the CORE VR is continuous inductor current sensing. Therefore, the controller can be less noise sensitive. Low offset amplifiers are used for loop control and over current detection. The internal current sense amplifier gain (Ai) is fixed to be 10. The ISENxP

and ISENxN denote the positive and negative input of the current sense amplifier of any phase.

Users can either use a current sense resistor or the inductor's DCR for current sensing. Using the inductor's DCR allows higher efficiency as shown in Figure 9. Refer to below equation for optimum transient performance :

$$\frac{L}{DCR} = R_X \times C_X \quad (15)$$

$$R_X = \frac{0.36\mu H}{1m\Omega \times 100nF} = 3.6k\Omega \quad (16)$$

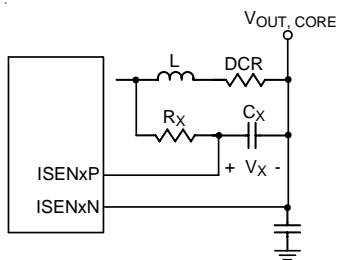

Figure 9. CORE VR : Lossless Inductor Sensing

Considering the inductance tolerance, the resistor R_X has to be tuned on board by examining the transient voltage. If the output voltage transient has an initial dip below the minimum load line requirement with a slow recovery, R_X is chosen too small. Vice versa, with a resistance too large the output voltage transient has only a small initial dip and the recovery is too fast causing a ring back.

Using current sense resistor in series with the inductor can have better accuracy, but the efficiency is a trade-off. Considering the equivalent inductance (L_{ESL}) of the current sense resistor, an RC filter is recommended. The RC filter calculation method is similar to the above mentioned inductor DCR sensing method.

Current Balance

The CORE VR implements internal current balance mechanism in the current loop. The CORE VR senses and compares per-phase current signal with average current. If the sensed current of any particular phase is larger than average current, the on-time of this phase will be adjusted to be shorter.

No Load Offset (SVID & Platform)

The CORE VR features no load offset function which provides the possibility of wide range positive offset of output voltage. The no-load offset function can be

implemented through the SVID interface or OFS pin. Users can disable pin offset function by simply connecting OFS pin to GND. The RT8859M will latch the OFS status after POR.

If pin offset function is enabled, users can decide whether to disable SVID OFS or not by selecting proper resistor values of ICCMAX pin. After receiving a valid VID, the RT8859M sinks in $16\mu A$ from ICCMAX pin. The voltage on ICCMAX is

$$V_{ICCMAX} = \frac{R_2}{R_1 + R_2} \times V_{CC} - 16\mu A (R_1/R_2) \quad (17)$$

If $V_{ICCMAX} < 1V$, then the output voltage is

$$V_{OUT} = V_{DAC} - I_{LOAD} \times R_{DROOP} + V_{PIN-OFS} \quad (18)$$

If $V_{ICCMAX} > 1V$, then the output voltage is

$$V_{OUT} = V_{DAC} - I_{LOAD} \times R_{DROOP} + V_{PIN-OFS} + V_{SVID-OFS} \quad (19)$$

The pin offset voltage is set by supplying a voltage into OFS pin. The linear range of offset pin voltage is from 0.9V to 1.83V. The pin offset voltage can be calculated as below :

$$V_{PIN-OFS} = V_{OFS} - 1.2V \quad (20)$$

For example, supplying 1.3V at OFS pin will achieve 100mV offset at the output. Connecting a filter capacitor between the OFS pin and GND is necessary. Designers can design the offset slew rate by properly setting the filter bandwidth.

Operation Mode Transition

RT8859M supports operation mode transition function at the CORE VR for the SetPS command of Intel's VR12/IMVP7 CPU. The default operation mode of the CORE VR is PS0, which is full phase CCM operation. Other operation modes includes PS1 (single phase CCM operation) and PS2 (single phase DEM operation).

After receiving SetPS command, the CORE VR will immediately change to the new operation state. When the CORE VR receives SetPS command of PS1 operation mode, the CORE VR operates as a single phase CCM controller, and only channel 1 is active. The CORE VR will disable phase 2, phase 3 and phase 4 by disabling Internal PWM logic drivers at PWM2, PWM3 and PWM4 pins (PWM = high impedance state). Therefore, 3 external drivers which support tri-state shutdown are required for compatibility with PS1 operation mode.

When the CORE VR receives SetPS command of PS2 operation mode, the CORE VR operates as a single phase DCM controller, and only channel 1 is active with diode emulation operation. The CORE VR will disable phase 2, phase 3 and phase 4 by disabling Internal PWM logic drivers at PWM2, PWM3 and PWM4 pins (PWM = high impedance state). Therefore, 4 external drivers which support tri-state shutdown are required for compatibility with PS2 operation state.

If the CORE VR receives dynamic VID change command (SetVID), the CORE VR will automatically enter PS0 operation mode and all phases will be activated. After $V_{OUT,CORE}$ reaches target voltage, the CORE VR will stay at PS0 state and ignore former SetPS command. Only re-sending SetPS command after SetVID command will the CORE VR be forced into PS1 or PS2 operation states again.

Dynamic VID Enhancement

During a dynamic VID event, the charging (dynamic VID up) or discharging (dynamic VID down) current causes unwanted load-line effect which degrades the settling time performance. The DVID pin can be used to compensate the load-line effect, so that the output voltage can settle to the target value more quickly.

During a dynamic VID up event, the RT8859M sources out a current (I_{DVID}) to DVID pin. The voltage on DVID pin is added to DAC during DVID rising to enhance the dynamic VID performance. Connecting a capacitor in parallel with a resistor to DVID pin is recommended.

I_{DVID} is $8\mu A$ during a SetVID_Fast event. If it is a SetVID_Slow event, I_{DVID} automatically shrinks to $2\mu A$ (if slow slew rate is 0.25x fast slew rate) or $4\mu A$ (if slow slew rate is 0.5x fast slew rate). This function is null during a dynamic VID down event.

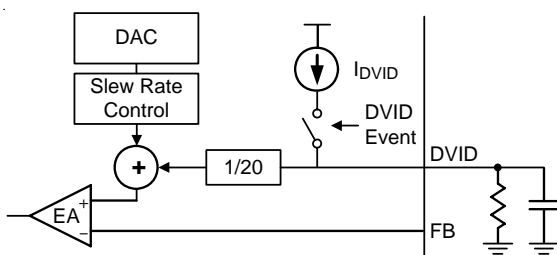

Figure 10. DVID Compensation Circuit

Ramp Amplitude Adjust

When the CORE VR enters PS2 operation mode, the internal ramp of CORE VR will be modified for the reason of stability. In case of smooth transition into PS2, the CCM ramp amplitude should be designed properly. The RT8859M provides RSET pin for platform users to set the ramp amplitude of the CORE VR in CCM. The criteria is to set the ramp amplitude proportional to the on-time (when $V_{DAC} < 1.2V$). The equation will be :

$$57.6 \times 10^{-12} = t_{ON} \times (V_{IN} - V_{DAC}) \times 1/RSET \quad (21)$$

where 57.6×10^{-12} is an internal coefficient of analog circuit.

According to equation (12), the RSET equation can be simplified to :

$$R_{RSET} = 0.4236 \times R_{TON} \quad (22)$$

Thermal Monitoring and Temperature Reporting

The CORE VR provides thermal monitoring function via sensing TSEN pin voltage. Through the voltage divider resistors, R1 and R_{NTC} , the voltage of TSEN will be proportional to VR temperature. When VR temperature rises, TSEN voltage also rises. The ADC circuit of the CORE VR monitors the voltage variation at the TSEN pin from 1.46V to 1.845V with 55mV resolution. This voltage is then decoded into digital format and stored into Temperature_Zone register.

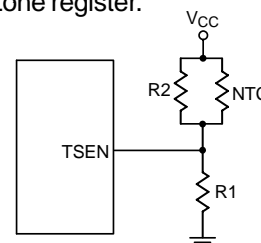

Figure 11. CORE VR : Thermal Monitoring Circuit

To meet Intel's VR12/IMVP7 specification, platform users have to set the TSEN voltage to meet the temperature variation of VR from 75% to 100% VR max temperature. For example, if the VR max temperature is $100^{\circ}C$, platform users have to set the TSEN voltage to be 1.515V when VR temperature reaches $82^{\circ}C$ and 1.845V when VR temperature reaches $100^{\circ}C$. Detailed voltage setting versus temperature variation is shown in Table 5. The thermometer code is implemented in Temperature_Zone register.

Table 5. Temperature_Zone Register

VRHOT	SVID Thermal Alert	Comparator Trip Points Temperatures Scaled to maximum = 100% Voltage Represents Assert bit Minimum Level					
		b5	b4	b3	b2	b1	b0
b7	b6	b5	b4	b3	b2	b1	b0
100%	97%	94%	91%	88%	85%	82%	75%
1.845V	1.79V	1.735V	1.68V	1.625V	1.57V	1.515V	1.46V

The VRHOT pin is an open-drain structure that sends out active low VRHOT signal. When b6 of Temperature_Zone register asserts to 1 (when TSEN voltage rises above 1.79V), the ALERT signal will be asserted to low, which is so-called SVID thermal alert. In the mean time, the CORE VR will assert bit 1 data to 1 in Status_1 register. The ALERT assertion will be de-asserted when b5 of Temperature_Zone register is de-asserted from 1 to 0 (which means TSEN voltage falls under 1.735V), and bit 1 of Status_1 register will also be cleared to 0. The bit 1 assertion of Status_1 is not latched and cannot be cleared by GetReg command.

When b7 of Temperature_Zone register asserts to 1 (when TSEN voltage rises above 1.845V), the VRHOT signal will be asserted to low. The VRHOT assertion will be de-asserted when b6 of Temperature_Zone register is de-asserted from 1 to 0 (which means TSEN voltage falls under 1.79V).

It is typically recommended to connect a pull-up resistor from the VRHOT pin to a voltage source.

Current Monitoring and Current Reporting

The CORE VR provides current monitoring function via sensing the voltage difference of IMONFEB pin and output voltage. In G-NAVP™ technology, the output voltage is dependent to output current, and the current monitoring function is achieved by this characteristic of output voltage. Figure 12 shows the current monitoring setting principle. The equivalent output current will be sensed from IMONFEB pin and mirrored to IMON pin. The resistor connected to IMON pin determines voltage gain of the IMON output.

The current monitor indicator equation is shown as :

$$V_{IMON} = \frac{I_{LOAD} \times R_{DROOP} \times R_{IMON}}{R_{IMONFB}} \tag{23}$$

where I_{LOAD} is the output load current, R_{DROOP} is the equivalent load line resistance, and R_{IMON} and R_{IMONFB} are the current monitor current setting resistors.

In VR12/IMVP7 specification, the voltage signal of current monitoring will be restricted by a maximum value. Platform designers have to select R_{IMON} to meet the maximum voltage of IMON at full load. To find R_{IMON} and R_{IMONFB} based on :

$$\frac{R_{IMON}}{R_{IMONFB}} = \frac{V_{IMON(MAX)}}{I_{MAX} \times R_{DROOP}} \tag{24}$$

where the V_{IMON(MAX)} is the maximum voltage at full load, and I_(MAX) is the full load current of VR.

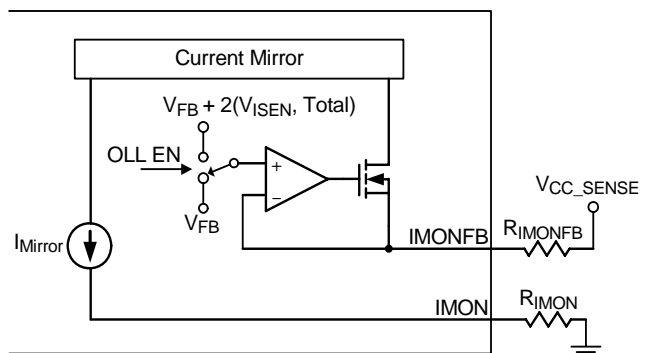

Figure 12. CORE VR : Current Monitoring Circuit

When the droop function is disabled, V_{CC_SENSE} no longer varies with output current, so the current monitoring function is adaptively changed internally under this situation. The equation will be rewritten as :

$$V_{IMON, NO_DROOP} = \frac{I_{LOAD} \times R_{DCR} \times R_{IMON} \times 2}{R_{IMONFB}} \tag{25}$$

$$\frac{R_{IMON}}{R_{IMONFB}} = \frac{V_{IMON(MAX)}}{I_{MAX} \times R_{DCR} \times 2} \tag{26}$$

The ADC circuit of the CORE VR monitors the voltage variation at the IMON pin from 0V to 3.3V, and this voltage is decoded into digital format and stored into Output_Current register. The ADC divides 3.3V into 255 levels, so LSB = 3.3V/255 = 12.941mV. Platform designers should design V_{IMON} to be 3.3V at ICCMAX. For example, when load current = 50% x ICCMAX, V_{IMON} = 1.65V and Output_Current register = 7Fh.

The IMON pin is an output of the internal operational amplifier and sends out IMON signal. When the data of Output_Current register reaches 255d (when IMON voltage rises above 3.3V), the ALERT signal will be asserted to low, which is so-called SVID ICCMAX alert. In the mean time, the CORE VR will assert the bit 2 data to 1 in Status_1 register. The ALERT assertion will be de-asserted when the data of Output_Current register decreases to 242d (when IMON voltage falls under 3.144V). The bit 2 assertion of Status_1 register is latched and can only be cleared when two criteria are met : the data of Output_Current register decreases to 242d (when IMON voltage falls under 3.144V) and the GetReg command is sent to the Status_1 register of the CORE VR.

Quick Response

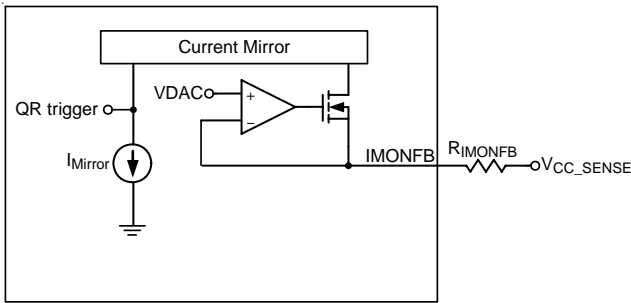

Figure 13. CORE VR : Quick Response Triggering Circuit

The CORE VR utilizes a quick response feature to support heavy load current demand during instantaneous load transient. The CORE VR monitors the current of the IMONFB pin, and this current is mirrored to internal quick response circuit. At steady state, this mirrored current will not trigger a quick response. When the $V_{OUT, CORE}$ voltage drops abruptly due to load apply transient, the mirrored current flowing into quick response circuit will also increase instantaneously. When the mirrored current instantaneously rises above $5\mu A$, quick response will be triggered.

When quick response is triggered, the quick response circuit will generate a quick response pulse. The internal quick response pulse generation circuit is similar to the on-time generation circuit. The only difference is the QRSET pin. The voltage at the QRSET pin also influences the pulse width of quick response. A voltage divider circuit is recommended to be applied to the QRSET pin.

Therefore, with a little modification of equation (12), the pulse width of quick response pulse can be calculated as :

$$t_{ON, QR} = \frac{V_{QRSET}}{1.2} \times t_{ON} = \frac{20.33 \times 10^{-12} \times R_{TON} \times V_{QRSET}}{V_{IN} - V_{DAC}} \quad (27)$$

After generating a quick response pulse, the pulse is then applied to the on-time generation circuit, and all the active phases' on-times will be overridden by the quick response pulse.

Over Current Protection

The CORE VR compares a programmable current limit set point to the voltage from the current sense amplifier output of each phase for Over Current Protection (OCP). Therefore, the OCP mechanism of the RT8859M implements per-phase current protections. The voltage applied to the OCSET pin defines the desired current limit threshold, I_{LIMIT} :

$$V_{OCSET} = 48 \times I_{LIMIT} \times R_{SENSE} \quad (28)$$

Connect a resistive voltage divider from V_{CC} to GND, and the joint of the resistive voltage divider is connected to the OCSET pin as shown in Figure 14. For a given R_{OC2} ,

$$R_{OC1} = R_{OC2} \times \left(\frac{V_{CC}}{V_{OCSET}} - 1 \right) \quad (29)$$

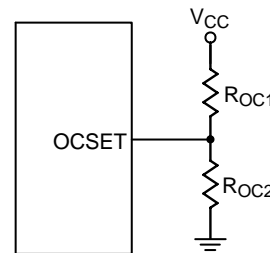

Figure 14. OCP Setting without Temperature Compensation

The current limit is triggered when per-phase inductor current exceeds the current limit threshold, I_{LIMIT} , as defined by V_{OCSET} . The driver will then be forced to turn off UGATE until the condition is cleared. If the over current condition of any phase remains valid for 15 cycles, the CORE VR will trigger OCP latch. Latched OCP forces PWM into high impedance, which disables internal PWM logic drivers. If the over current condition is not valid for 15

continuous cycles, the OCP latch counter will be reset. When OCP is triggered by the CORE VR, the AXG VR will also enter soft shut down sequence.

If inductor DCR is used as the current sense component, temperature compensation is recommended for proper protection under all conditions. Figure 15 shows a typical OCP setting with temperature compensation.

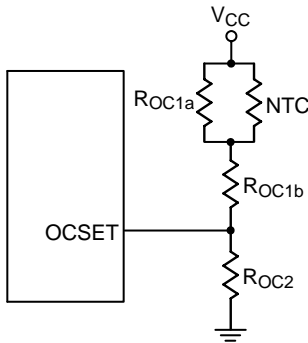

Figure 15. OCP Setting with Temperature Compensation

Usually, R_{OC1a} is selected to be equal to the thermistor's nominal resistance at room temperature. Ideally, assume V_{OCSET} has the same temperature coefficient as R_{SENSE} (Inductor DCR) :

$$\frac{V_{OCSET, HOT}}{V_{OCSET, COLD}} = \frac{R_{SENSE, HOT}}{R_{SENSE, COLD}} \quad (30)$$

According to the basic circuit calculation, we can get V_{OCSET} at any temperature:

$$V_{OCSET, T^{\circ}C} = V_{CC} \times \frac{R_{OC2}}{R_{OC1a} // R_{NTC, T^{\circ}C} + R_{OC1b} + R_{OC2}} \quad (31)$$

Re-write (31) from (30) to get V_{OCSET} at room temperature

$$\frac{R_{OC1a} // R_{NTC, COLD} + R_{OC1b} + R_{OC2}}{R_{OC1a} // R_{NTC, HOT} + R_{OC1b} + R_{OC2}} = \frac{R_{SENSE, HOT}}{R_{SENSE, COLD}} \quad (32)$$

$$V_{OCSET, 25^{\circ}C} = V_{CC} \times \frac{R_{OC2}}{R_{OC1a} // R_{NTC, 25^{\circ}C} + R_{OC1b} + R_{OC2}} \quad (33)$$

Solving (32) and (33) yields R_{OC1b} and R_{OC2}

$$R_{OC2} = \frac{\alpha \times R_{EQU, HOT} - R_{EQU, COLD} + (1 - \alpha) \times R_{EQU, 25^{\circ}C}}{\frac{V_{CC}}{V_{OCSET, 25^{\circ}C}} \times (1 - \alpha)} \quad (34)$$

$$R_{OC1b} = \frac{(\alpha - 1) \times R_{OC2} + \alpha \times R_{EQU, HOT} - R_{EQU, COLD}}{(1 - \alpha)} \quad (35)$$

where

$\alpha =$

$$\frac{R_{SENSE, HOT}}{R_{SENSE, COLD}} = \frac{DCR_{25^{\circ}C} \times [1 + 0.00393 \times (T_{HOT} - 25)]}{DCR_{25^{\circ}C} \times [1 + 0.00393 \times (T_{COLD} - 25)]} \quad (36)$$

$$R_{EQU, T^{\circ}C} = R_{OC1a} // R_{NTC, T^{\circ}C} \quad (37)$$

Over Voltage Protection (OVP)

The over voltage protection circuit of the CORE VR monitors the output voltage via the ISEN1N pin after POR. The supported maximum operating VID of the VR ($V_{(MAX)}$) is stored in the VOUT_Max register. Once V_{ISEN1N} exceeds " $V_{(MAX)} + 150mV$ ", OVP is triggered and latched. The CORE VR will try to turn on low side MOSFETs and turn off high side MOSFETs of all active phases of the CORE VR to protect the CPU. When OVP is triggered by the CORE VR, the AXG VR will also enter soft shut down sequence. A $1\mu s$ delay is used in OVP detection circuit to prevent false trigger. Note that if OFS pin is higher than 0.9V before power up, OVP will trigger at " $V_{MAX} + 850mV$ ".

Negative Voltage Protection (NVP)

During OVP latch state, the CORE VR also monitors the ISEN1N pin for negative voltage protection. Since the OVP latch will continuously turn on all low side MOSFETs of the CORE VR, the CORE VR may suffer negative output voltage. As a consequence, when the ISEN1N voltage drops below $-0.05V$ after triggering OVP, the CORE VR will trigger NVP to turn off all low side MOSFETs of the CORE VR while the high side MOSFETs still remains off. After triggering NVP, if the output voltage rises above 0V, the OVP latch will restart to turn on all low side MOSFETs. Therefore, the output voltage may travel between 0V and $-0.05V$ due to OVP latch and NVP triggering. The NVP function will be active only after OVP is triggered. A $1\mu s$ delay is used in NVP detection circuit to prevent false trigger.

Under Voltage Protection (UVP)

The CORE VR implements under voltage protection of $V_{OUT, CORE}$. If ISEN1N is less than the internal reference

by 300mV, the CORE VR will trigger UVP latch. The UVP latch will turn off both high side and low side MOSFETs. When UVP is triggered by the CORE VR, the AXG VR will also enter soft shut down sequence. A 3μs delay is used in UVP detection circuit to prevent false trigger. If platform OFS function is enabled (OFS pin not connected to GND), the UVP function will be disabled.

Under Voltage Lock Out (UVLO)

During normal operation, if the voltage at the VCC or DVD pin drops below POR threshold, the CORE VR will trigger UVLO. The UVLO protection forces all high side MOSFETs and low side MOSFETs off by shutting down internal PWM logic drivers. A 3μs delay is used in UVLO detection circuit to prevent false trigger.

AXG VR

AXG VR Disable

The AXG VR can be disabled by connecting ISENAN to a voltage higher than “V_{CC} – 1V”. If not in use, ISENAP, TSENA and DVDA are recommended to be connected to VCC, while PWMA is left floating. When AXG VR is disabled, all SVID commands related to AXG VR will be rejected.

Loop Control

The AXG VR adopts Richtek’s proprietary G-NAVP™ topology. G-NAVP™ is based on the finite gain peak current mode with CCRCOT (Constant Current Ripple Constant On-Time) topology. The output voltage, V_{OUT, AXG}, will decrease with increasing output load current. The control loop consists of a PWM modulator with power stage, a current sense amplifier and an error amplifier as shown in Figure 16.

Similar to the peak current mode control with finite compensator gain, the HS_FET on-time is determined by CCRCOT on-time generator. When load current increases, V_{CS} increases, the steady state COMPA voltage also increases and induces V_{OUT, AXG} to decrease, thus achieving AVP. A near-DC offset canceling is added to the output of EA to cancel the inherent output offset of finite-gain peak current mode controller.

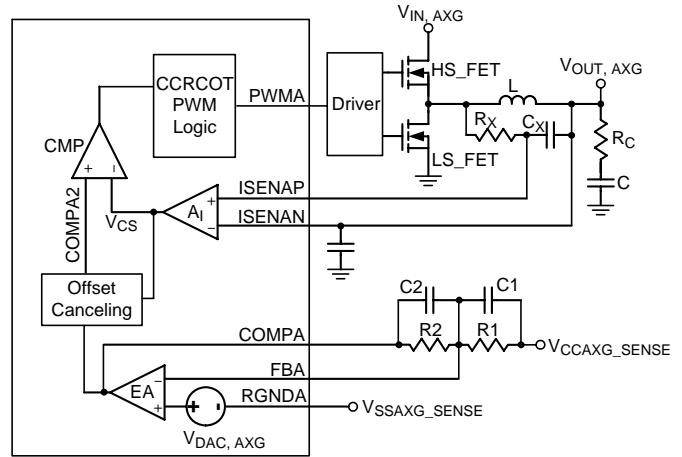

Figure 16. AXG VR : Simplified Schematic for Droop and Remote Sense in CCM

Droop Setting (with Temperature Compensation)

It’s very easy to achieve Active Voltage Positioning (AVP) by properly setting the error amplifier gain due to the native droop characteristics. The target is to have

$$V_{OUT, AXG} = V_{DAC, AXG} - I_{LOAD} \times R_{DROOP} \tag{38}$$

, then solving the switching condition V_{COMP2} = V_{CS} in Figure 16 yields the desired error amplifier gain as

$$A_V = \frac{R_2}{R_1} = \frac{A_I \times R_{SENSE}}{R_{DROOP}} \tag{39}$$

where A_I is the internal current sense amplifier gain, R_{SENSE} is the current sense resistance (an external sense resistor or the DCR of the inductor), and R_{DROOP} is the equivalent load line resistance as well as the desired static output impedance.

Since the DCR of the inductor is temperature dependent, the output accuracy may be affected at high temperature conditions. Temperature compensation is recommended for the lossless inductor DCR current sense method. Figure 17 shows a simple but effective way of compensating the temperature variations of the sense resistor by using an NTC thermistor placed in the feedback path.

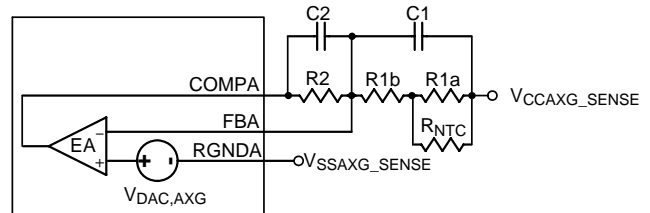

Figure 17. AXG VR : Loop Setting with Temperature Compensation

Usually, R_{1a} is set to equal $R_{NTC(25^{\circ}C)}$ and R_{1b} is selected to linearize the NTC's temperature characteristic. For a given NTC, the design procedure is to get R_{1b} and R_2 first, and then C_1 and C_2 next. According to equation (39), to compensate the temperature variations of the sense resistor, the error amplifier gain (A_V) should have the same temperature coefficient as R_{SENSE} . Hence :

$$\frac{A_{V, HOT}}{A_{V, COLD}} = \frac{R_{SENSE, HOT}}{R_{SENSE, COLD}} \quad (40)$$

From (37), A_V can be obtained at any temperature ($T^{\circ}C$) as :

$$A_{V, T^{\circ}C} = \frac{R_2}{R_{1a} // R_{NTC, T^{\circ}C} + R_{1b}} \quad (41)$$

The standard formula for the resistance of NTC thermistor as a function of temperature is given by :

$$R_{NTC, T^{\circ}C} = R_{25^{\circ}C} e^{\left\{ \beta \left[\left(\frac{1}{T+273} \right) - \left(\frac{1}{298} \right) \right] \right\}} \quad (42)$$

where $R_{25^{\circ}C}$ is the thermistor's nominal resistance at room temperature, β is the thermistor's material constant in Kelvins, and T is the thermistor actual temperature in Celsius.

To calculate DCR value at different temperatures, use the equation below :

$$DCR_{T^{\circ}C} = DCR_{25^{\circ}C} \times [1 + 0.00393 \times (T - 25)] \quad (43)$$

where 0.00393 is the temperature coefficient of copper. For a given NTC thermistor, solving equation (41) at room temperature ($25^{\circ}C$) yields

$$R_2 = A_{V, 25^{\circ}C} \times (R_{1b} + R_{1a} // R_{NTC, 25^{\circ}C}) \quad (44)$$

where $A_{V, 25^{\circ}C}$ is the error amplifier gain at room temperature and can be obtained from equation (39). R_{1b} can be obtained by substituting (44) to (40),

$$R_{1b} = \frac{\frac{R_{SENSE, HOT}}{R_{SENSE, COLD}} \times (R_{1a} // R_{NTC, HOT}) - (R_{1a} // R_{NTC, COLD})}{\left(1 - \frac{R_{SENSE, HOT}}{R_{SENSE, COLD}} \right)} \quad (45)$$

Droop Disable

The AXG VR's droop function can be enabled or disabled with different connections of the QRSETA pin. The connection of the QRSETA pin is usually a voltage divider

circuit which is described later in the Quick Response section. Before POR, the RT8859M will source $80\mu A$ current from the QRSETA pin to the external voltage divider to determine the voltage level while the RT8859M is still not powered on. Before POR, if the voltage at the QRSETA pin is higher than 4.5V, the AXG VR will operate in droop-enabled mode. If the voltage is lower than 3.2V, the AXG VR will operate without droop function, which means at the DC level of DAC voltage. For example, a 5V voltage divided by two $1k\Omega$ resistors connected to the QRSETA pin generates 2.54V ($5V/2 + 80\mu A \times 1k\Omega/2$) before POR and 2.5V ($5V/2$) after POR.

Loop Compensation

Optimized compensation of the AXG VR allows for best possible load step response of the regulator's output. A type-I compensator with one pole and one zero is adequate for a proper compensation. Figure 17 shows the compensation circuit. Prior design procedure shows how to select the resistive feedback components for the error amplifier gain. Next, C_1 and C_2 must be calculated for the compensation. The target is to achieve constant resistive output impedance over the widest possible frequency range.

The pole frequency of the compensator must be set to compensate the output capacitor ESR zero :

$$f_p = \frac{1}{2 \times \pi \times C \times R_C} \quad (46)$$

where C is the capacitance of output capacitor, and R_C is the ESR of output capacitor. C_2 can be calculated as below :

$$C_2 = \frac{C \times R_C}{R_2} \quad (47)$$

The zero of compensator has to be placed at half of the switching frequency to filter the switching related noise. Such that,

$$C_1 = \frac{1}{(R_{1b} + R_{1a} // R_{NTC, 25^{\circ}C}) \times \pi \times f_{SW}} \quad (48)$$

TON Setting

High frequency operation optimizes the application by allowing smaller component size, but with the trade-off of efficiency due to higher switching losses. This may be acceptable in ultra portable devices where the load currents

are lower and the controller is powered from a lower voltage supply. Low frequency operation offers the best overall efficiency at the expense of component size and board space. Figure 19 shows the on-time setting circuit. Connect a resistor (R_{TON}) between $V_{IN,GFX}$ and TONSETA to set the on-time of UGATE :

$$t_{ON} (V_{DAC} < 1.2V) = \frac{24.4 \times 10^{-12} \times R_{TON}}{V_{IN} - V_{DAC,GFX}} \quad (49)$$

where t_{ON} is the UGATE turn-on period, V_{IN} is the input voltage of the AXG VR, and $V_{DAC,AXG}$ is the DAC voltage.

When $V_{DAC,AXG}$ is larger than 1.2V, the equivalent switching frequency may be too fast at over 500kHz, which is unacceptable. Therefore, the AXG VR implements a pseudo constant frequency technology to avoid this disadvantage of CCRCOT topology. When $V_{DAC,AXG}$ is larger than 1.2V, the on-time equation will be modified to :

$$t_{ON} (V_{DAC} \geq 1.2V) = \frac{20.33 \times 10^{-12} \times R_{TON} \times V_{DAC,AXG}}{V_{IN} - V_{DAC,AXG}} \quad (50)$$

On-time translates only roughly to switching frequencies. The on-times guaranteed in the Electrical Characteristics are influenced by switching delays in the external HS-FET. Also, the dead-time effect increases the effective on-time, which in turn reduces the switching frequency. It occurs only in CCM, and during dynamic output voltage transitions when the inductor current reverses at light or negative load currents. With reversed inductor current, the phase go high earlier than normal, extending the on-time by a period equal to the HS-FET rising dead time. For better efficiency of the given load range, the maximum switching frequency is suggested to be :

$$f_{S(MAX)}(kHz) = \frac{1}{t_{ON} - T_{HS-Delay}} \times$$

$$\frac{V_{DAC(MAX)} + I_{LOAD(MAX)} \times [R_{ON_LS-FET} + DCR - R_{DROOP}]}{V_{IN(MAX)} + I_{LOAD(MAX)} \times [R_{ON_LS-FET} - R_{ON_HS-FET}]} \quad (51)$$

where $f_{S(MAX)}$ is the maximum switching frequency, $T_{HS-DELAY}$ is the turn-on delay of HS-FET, $V_{DAC(MAX)}$ is the maximum $V_{DAC,AXG}$ of application, $V_{IN(MAX)}$ is the maximum application input voltage, $I_{LOAD(MAX)}$ is the maximum load of application, R_{ON_LS-FET} is the Low side FET $R_{DS(ON)}$, R_{ON_HS-FET} is the High side FET $R_{DS(ON)}$, DCR is the inductor DCR, and R_{DROOP} is the load line setting.

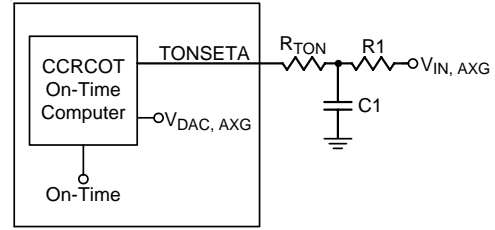

Figure 18. AXG VR : On-Time setting with RC Filter

Differential Remote Sense Setting

The AXG VR includes differential, remote sense inputs to eliminate the effects of voltage drops along the PC board traces, CPU internal power routes and socket contacts. The CPU contains on-die sense pins V_{CCAXG_SENSE} and V_{SSAXG_SENSE} . Connect the RGNDA to V_{SSAXG_SENSE} . Connect the FBA to V_{CCAXG_SENSE} with a resistor to build the negative input path of the error amplifier. The $V_{DAC,AXG}$ and the precision voltage reference are referred to RGNDA for accurate remote sensing.

Current Sense Setting

The current sense topology of the AXG VR is continuous inductor current sensing. Therefore, the controller can be less noise sensitive. Low offset amplifiers are used for loop control and over current detection. The internal current sense amplifier gain (A_i) is fixed to be 20. The ISENAP and ISENAN denote the positive and negative input of the current sense amplifier.

Users can either use a current sense resistor or the inductor's DCR for current sensing. Using inductor's DCR allows higher efficiency as shown in Figure 19. Refer to below equation for optimum transient performance :

$$\frac{L}{DCR} = R_X \times C_X \quad (52)$$

For example, choosing $L = 0.36\mu H$ with $1m\Omega$ DCR and $C_X = 100nF$ yields :

$$R_X = \frac{0.36\mu H}{1m\Omega \times 100nF} = 3.6k\Omega \quad (53)$$

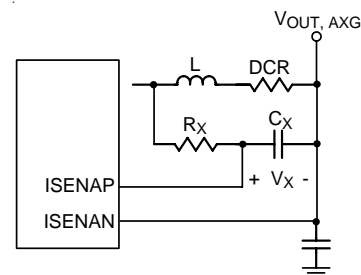

Figure 19. AXG VR : Lossless Inductor Sensing

Considering the inductance tolerance, the resistor R_X has to be tuned on board by examining the transient voltage. If the output voltage transient has an initial dip below the minimum load line requirement with a slow recovery, R_X is chosen too small. Vice versa, if the resistance is too large the output voltage transient has only a small initial dip and the recovery becomes too fast, causing a ring back to occur.

Using current sense resistor in series with the inductor can have better accuracy, but at the expense of efficiency. Considering the equivalent inductance (LESL) of the current sense resistor, an RC filter is recommended. The RC filter calculation method is similar to the above mentioned inductor DCR sensing method.

No Load Offset (SVID & Platform)

The AXG VR features no load offset function which provides the possibility of wide range positive offset of output voltage. The no load offset function can be implemented through the SVID interface or OFSA pin. Users can disable pin offset function by simply connecting OFSA pin to GND. The RT8859M will latch the OFSA status after POR.

If pin offset function is enabled, users can decide either to disable SVID OFS or not by selecting proper resistor values of TMPMAX pin. After receiving a valid VID, the RT8859M sinks in $16\mu\text{A}$ from TMPMAX pin. The voltage on TMPMAX is

$$V_{\text{TMPMAX}} = \frac{R_2}{R_1 + R_2} \times V_{\text{CC}} - 16\mu\text{A} (R_1 // R_2) \quad (54)$$

If $V_{\text{TMPMAX}} < 1\text{V}$, then the output voltage is

$$V_{\text{OUT}} = V_{\text{DAC}} - I_{\text{LOAD}} \times R_{\text{DROOP}} + V_{\text{PIN-OFS}} \quad (55)$$

If $V_{\text{TMPMAX}} > 1\text{V}$, then the output voltage is

$$V_{\text{OUT}} = V_{\text{DAC}} - I_{\text{LOAD}} \times R_{\text{DROOP}} + V_{\text{PIN-OFS}} + V_{\text{SVID-OFS}} \quad (56)$$

The pin offset voltage is set by supplying a voltage into OFSA pin. The linear range of offset pin voltage is from 0.9V to 1.83V. The pin offset voltage can be calculated as below :

$$V_{\text{PIN-OFS}} = V_{\text{OFS}} - 1.2\text{V} \quad (57)$$

For example, supplying 1.3V at OFSA pin will achieve 100mV offset at the output. Connecting a filter capacitor

between the OFSA pin and GND is necessary. Designers can design the offset slew rate by properly setting the filter bandwidth.

Operation Mode Transition

The RT8859M supports operation mode transition function at AXG VR for the SetPS command of Intel VR12/IMVP7 CPU. The default operation mode of the AXG VR is PS0, which is CCM operation. Other operation mode includes PS2 (single phase DEM operation).

After receiving SetPS command, the AXG VR will immediately change to the new operation state. When the AXG VR receives SetPS command of PS2 operation mode, the AXG VR operates as a single phase DCM controller and diode emulation operation is activated. Therefore, an external driver which supports tri-state shutdown is required for compatibility with PS2 operation state.

If the AXG VR receives dynamic VID change command (SetVID), the AXG VR will automatically enter PS0 operation mode. After $V_{\text{OUT, AXG}}$ reaches target voltage, the AXG VR will stay at PS0 state and ignore former SetPS command. Only by resending SetPS command after SetVID command will the AXG VR be forced into PS2 operation state again.

Dynamic VID Enhancement

During a dynamic VID event, the charging (dynamic VID up) or discharging (dynamic VID down) current causes unwanted load-line effect which degrades the settling time performance. The DVIDA pin can be used to compensate the load-line effect, so that the output voltage can settle to the target value more quickly.

During a dynamic VID up event, the RT8859M sources out a current (I_{DVIDA}) to DVIDA pin. The voltage on DVIDA pin is added to DAC during DVID rising to enhance the dynamic VID performance. Connecting a capacitor in parallel with a resistor to DVIDA pin is recommended.

I_{DVIDA} is $8\mu\text{A}$ during a SetVID_Fast event. If it is a SetVID_Slow event, I_{DVIDA} automatically shrinks to $2\mu\text{A}$ (if slow slew rate is 0.25x fast slew rate) or $4\mu\text{A}$ (if slow slew rate is 0.5x fast slew rate). This function is null during a dynamic VID down event.

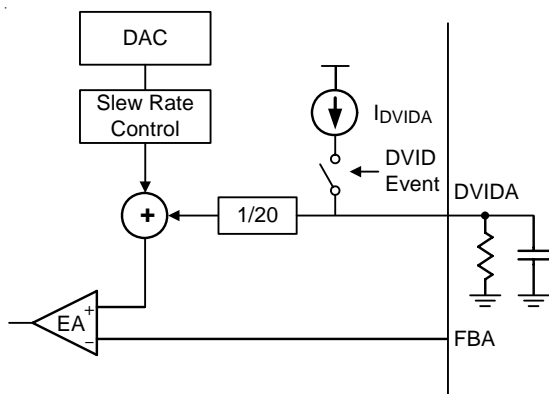

Figure 20. DVID Compensation Circuit

Thermal Monitoring and Temperature Reporting

The AXG VR provides thermal monitoring function via sensing TSENA pin voltage. Through the voltage divider resistors, R1 and R_{NTC}, the voltage of TSENA will be proportional to VR temperature. When VR temperature rises, the TSENA voltage also rises. The ADC circuit of the AXG VR monitors the voltage variation at the TSENA pin from 1.46V to 1.845V with 55mV resolution. This voltage is then decoded into digital format and stored into Temperature_Zone register.

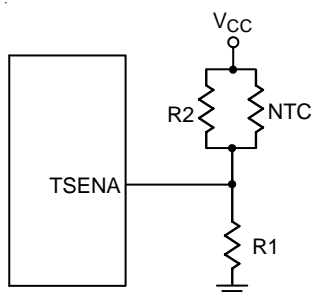

Figure 21. AXG VR : Thermal Monitoring Circuit

To meet Intel's VR12/IMVP7 specification, platform users have to set the TSENA voltage to meet the temperature variation of VR from 75% to 100% VR max temperature. For example, if the VR max temperature is 100°C, platform users have to set the TSENA voltage to be 1.46V when VR temperature reaches 75°C and 1.845V when VR temperature reaches 100°C. Detailed voltage setting versus temperature variation is shown in Table 6. The thermometer code is implemented in Temperature_Zone register.

Table 6. Temperature_Zone register

VRHOT	SVID Thermal Alert
b7	b6
100%	97%
1.845V	1.79V

Comparator Trip Points Temperatures Scaled to maximum = 100% Voltage Represents Assert bit Minimum Level					
b5	b4	b3	b2	b1	b0
94%	91%	88%	85%	82%	75%
1.735V	1.68V	1.625V	1.57V	1.515V	1.46V

The VRHOT pin is an open-drain structure that sends out active-low VRHOT signal. When b6 of Temperature_Zone register asserts to 1 (when TSENA voltage rises above 1.79V), the ALERT signal will be asserted to low, which is so-called SVID thermal alert. In the mean time, the AXG VR will assert the bit 1 data to 1 in Status_1 register. The ALERT assertion will be de-asserted when b5 of Temperature_Zone register is de-asserted from 1 to 0 (which means TSENA voltage falls under 1.735V), and the bit 1 of Status_1 register will also be cleared to 0. The bit 1 assertion of Status_1 is not latched and cannot be cleared by GetReg command.

When b7 of Temperature_Zone register asserts to 1 (when TSENA voltage rises above 1.845V), the VRHOT signal will be asserted to low. The VRHOT assertion will be de-asserted when b6 of Temperature_Zone register is de-asserted from 1 to 0 (which means TSENA voltage falls under 1.79V).

The thermal monitoring function of the AXG VR can be disabled by connecting TSENA to VCC. If TSENA is disabled, all the SVID commands related to Temperature_Zone register of the AXG VR will be rejected.

Current Monitoring and Current Reporting

The AXG VR provides current monitoring function via sensing the IMONFBA pin. In G-NAVP™ technology, the output voltage is dependent on the output current, and the current monitoring function is achieved by this output voltage characteristic. Figure 22 shows the current monitoring setting principle. The equivalent output current will be sensed from the IMONFBA pin and mirrored to the

IMONA pin. The resistor connected to the IMONA pin determines the voltage gain of the IMONA output.

The current monitor indicator equation is shown as :

$$V_{IMONA} = \frac{I_{LOAD} \times R_{DROOP} \times R_{IMONA}}{R_{IMONFBA}} \tag{58}$$

Where I_{LOAD} is the output load current, R_{DROOP} is the equivalent load line resistance, and R_{IMONA} and $R_{IMONFBA}$ are the current monitor current setting resistors.

In VR12/IMVP7 specification, the voltage signal of current monitoring will be restricted by a maximum value. Platform designers have to select R_{IMONA} to meet the maximum voltage of IMONA at full load. Find R_{IMONA} and $R_{IMONFBA}$ based on :

$$\frac{R_{IMONA}}{R_{IMONFBA}} = \frac{V_{IMONA(MAX)}}{I_{MAX} \times R_{DROOP}} \tag{59}$$

where $V_{IMONA(MAX)}$ is the maximum voltage at full load, and I_{MAX} is the full load current of VR.

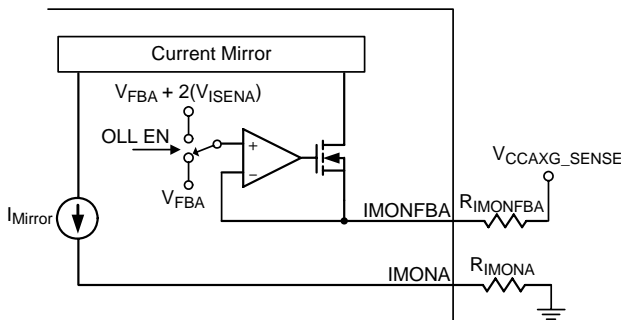

Figure 22. AXG VR : Current Monitoring Circuit

When the droop function is disabled, V_{CCAXG_SENSE} no longer varies with output current, so the current monitoring function is adaptively changed internally under this situation. The equation will be rewritten as :

$$V_{IMONA, NO_DROOP} = \frac{2 \times I_{LOAD} \times R_{RDCR} \times R_{IMONA}}{R_{IMONFBA}} \tag{60}$$

$$\frac{R_{IMONA}}{R_{IMONFBA}} = \frac{V_{IMONA(MAX)}}{2 \times I_{MAX} \times R_{DCR}} \tag{61}$$

The ADC circuit of the AXG VR monitors the voltage variation at the IMONA pin from 0V to 3.3V, and this voltage is decoded into digital format and stored into the Output_Current register. The ADC divides 3.3V into 255 levels, so $LSB = 3.3V/255 = 12.941mV$. Platform

designers should design V_{IMONA} to be 3.3V at ICCMAXA. For example, when load current = 50% x ICCMAXA, $V_{IMONA} = 1.65V$ and Output_Current register = 7Fh.

The IMONA pin is an output of the internal operational amplifier and sends out IMONA signal. When the data of Output_Current register reaches 255d (when IMONA voltage rises above 3.3V), the ALERT signal will be asserted to low, which is so-called SVID ICCMAXA alert. In the mean time, the AXG VR will assert the bit 2 data to 1 in Status_1 register. The ALERT assertion will be de-asserted when the data of Output_Current register decreases to 242d (when IMONA voltage falls under 3.144V). The bit 2 assertion of Status_1 register is latched and can only be cleared when two criteria are met : the data of Output_Current register decreases to 242d (when IMONA voltage falls under 3.144V) and the GetReg command is sent to the Status_1 register of the AXG VR.

Quick Response

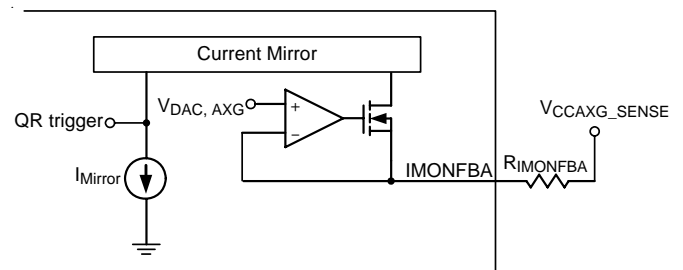

Figure 23. AXG VR : Quick Response Triggering Circuit

The AXG VR utilizes a quick response feature to support heavy load current demand during instantaneous load transient. The AXG VR monitors the current of the IMONFBA pin, and this current is mirrored to internal quick response circuit. At steady state, this mirrored current will not trigger a quick response. When the $V_{OUT,AXG}$ voltage drops abruptly due to load apply transient, the mirrored current into quick response circuit will also increase instantaneously. When the mirrored current instantaneously rises above 5µA, quick response will be triggered.

When quick response is triggered, the quick response circuit will generate a quick response pulse. The internal quick response pulse generation circuit is similar to the on-time generation circuit. The only difference is the QRSETA pin. The voltage at the QRSETA pin also

influences the pulse width of quick response. A voltage divider circuit is recommended to be applied to the QRSETA pin. Therefore, with a little modification of equation (49), the pulse width of quick response pulse can be calculated as :

$$t_{ON, QR} = \frac{V_{QRSETA}}{1.2} \times t_{ON}$$

$$= \frac{20.33 \times 10^{-12} \times R_{TON} \times V_{QRSETA}}{V_{IN} - V_{DAC, AXG}} \quad (62)$$

After generating a quick response pulse, the pulse is then applied to the on-time generation circuit and the AXG VR's on-time will be overridden by the quick response pulse.

Over Current Protection

The AXG VR compares a programmable current limit set point to the voltage from the current sense amplifier output of each phase for Over Current Protection (OCP). Therefore, the OCP mechanism of the RT8859M implements per-phase current protections. The voltage applied to the OCSETA pin defines the desired current limit threshold I_{LIMIT} :

$$V_{OCSETA} = 48 \times I_{LIMIT} \times R_{SENSE} \quad (63)$$

Connect a resistive voltage divider from V_{CC} to GND, and the joint of the resistive voltage divider is connected to the OCSETA pin as shown in Figure 24. For a given R_{OC2} ,

$$R_{OC1} = R_{OC2} \times \left(\frac{V_{CC}}{V_{OCSET}} - 1 \right)$$

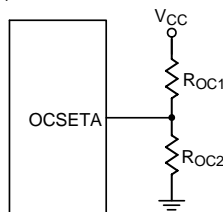

Figure 24. AXG VR : OCP Setting without Temperature Compensation

The current limit is triggered when inductor current exceeds the current limit threshold, I_{LIMIT} , as defined by V_{OCSETA} . The driver will then be forced to turn off UGATE until the condition is cleared. If the over current condition of any phase remains valid for 15 cycles, the AXG VR will trigger OCP latch. Latched OCP forces PWM into high impedance, which disables internal PWM logic drivers. If

the over current condition is not valid for 15 continuous cycles, the OCP latch counter will be reset. When OCP is triggered by the AXG VR, the CORE VR will also enter soft shut down sequence.

If inductor DCR is used as the current sense component, temperature compensation is recommended for proper protection under all conditions. Figure 25 shows a typical OCP setting with temperature compensation.

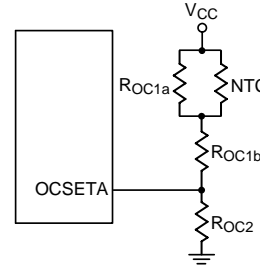

Figure 25. AXG VR : OCP Setting with Temperature Compensation

Usually, R_{OC1a} is Selected to be equal to the thermistor's nominal resistance at room temperature. Ideally, assume V_{OCSET} has the same temperature coefficient as R_{SENSE} (Inductor DCR) :

$$\frac{V_{OCSETA, HOT}}{V_{OCSETA, COLD}} = \frac{R_{SENSE, HOT}}{R_{SENSE, COLD}} \quad (64)$$

According to the basic circuit calculation, we can get V_{OCSETA} at any temperature :

$$V_{OCSETA, T^{\circ}C} = V_{CC} \times \frac{R_{OC2}}{R_{OC1a} // R_{NTC, 25^{\circ}C} + R_{OC1b} + R_{OC2}} \quad (65)$$

Re-write (64) from (65) to get V_{OCSETA} at room temperature:

$$\frac{R_{OC1a} // R_{NTC, COLD} + R_{OC1b} + R_{OC2}}{R_{OC1a} // R_{NTC, HOT} + R_{OC1b} + R_{OC2}} = \frac{R_{SENSE, HOT}}{R_{SENSE, COLD}} \quad (66)$$

$$V_{OCSETA, 25^{\circ}C} = V_{CC} \times \frac{R_{OC2}}{R_{OC1a} // R_{NTC, 25^{\circ}C} + R_{OC1b} + R_{OC2}} \quad (67)$$

Solving (66) and (67) yields R_{OC1b} and R_{OC2}

$$R_{OC2} = \frac{\alpha \times R_{EQU, HOT} - R_{EQU, COLD} + (1 - \alpha) \times R_{EQU, 25^{\circ}C}}{\frac{V_{CC}}{V_{OCSETA, 25^{\circ}C}} \times (1 - \alpha)} \quad (68)$$

$$R_{OC1b} = \frac{(\alpha - 1) \times R_{OC2} + \alpha \times R_{EQU, HOT} - R_{EQU, COLD}}{(1 - \alpha)} \quad (69)$$

where

$$\alpha = \frac{R_{SENSE, HOT}}{R_{SENSE, COLD}} = \frac{DCR_{25^{\circ}C} \times [1 + 0.00393 \times (T_{HOT} - 25)]}{DCR_{25^{\circ}C} \times [1 + 0.00393 \times (T_{COLD} - 25)]} \quad (70)$$

$$R_{EQU, T^{\circ}C} = R_{OC1a} // R_{NTC, T^{\circ}C} \quad (71)$$

Over Voltage Protection (OVP)

The over voltage protection circuit of the AXG VR monitors the output voltage via the ISENAN pin after POR. The supported maximum operating VID of the VR ($V_{(MAX)}$) is stored in the VOUT_Max register. Once VISENAN exceeds " $V_{(MAX)} + 150mV$ ", OVP is triggered and latched. The AXG VR will try to turn on low side MOSFETs and turn off high side MOSFETs of the AXG VR to protect the CPU. When OVP is triggered by the AXG VR, the CORE VR will also enter shut down sequence. A $1\mu s$ delay is used in OVP detection circuit to prevent false trigger. Note that if OFSA pin is higher than 0.9V before power up, OVP would trigger when " $V_{MAX} + 850mV$ ".

Negative Voltage Protection (NVP)

During OVP latch state, the AXG VR also monitors the ISENAN pin for negative voltage protection. Since the OVP latch will continuously turn on all low side MOSFETs of the AXG VR, the AXG VR may suffer negative output voltage. As a consequence, when the ISENAN voltage drops below $-0.05V$ after triggering OVP, the AXG VR will trigger NVP to turn off all low side MOSFETs of the AXG VR while the high side MOSFETs still remaining off. After triggering NVP, if the output voltage rises above 0V, the OVP latch will restart to turn on all low side MOSFETs. Therefore, the output voltage may bounce between 0V and $-0.05V$ due to OVP latch and NVP triggering. The NVP function will be active only after OVP is triggered. A $1\mu s$ delay is used in NVP detection circuit to prevent false trigger.

Under Voltage Protection (UVP)

The AXG VR implements under voltage protection of $V_{OUT, AXG}$. If V_{FBA} is less than the internal reference by 300mV,

the AXG VR will trigger UVP latch. The UVP latch will turn off both high side and low side MOSFETs. When UVP is triggered by the AXG VR, the CORE VR will also enter soft shut down sequence. A $3\mu s$ delay is used in UVP detection circuit to prevent false trigger. If platform OFSA function is enabled (OFSA pin not connected to GND), the UVP function will be disabled.

Under Voltage Lock Out (UVLO)

During normal operation, if the voltage at the VCC or DVD pin drops below POR threshold, the AXG VR will trigger UVLO. The UVLO protection forces all high side MOSFETs and low side MOSFETs off by shutting down internal PWM logic driver. A $3\mu s$ delay is used in UVLO detection circuit to prevent false trigger.

Inductor Selection

The switching frequency and ripple current determine the inductor value as follows :

$$L_{MIN} = \frac{V_{IN} - V_{OUT}}{I_{Ripple(MAX)}} \times T_{ON} \quad (72)$$

where t_{ON} is the UGATE turn-on period.

Higher inductance yields in less ripple current and hence higher efficiency. The downside is a slower transient response of the power stage to load transients. This might increase the need for more output capacitors, thus driving up the cost. Select a low loss inductor having the lowest possible DC resistance that fits in the allotted dimensions. The core must be large enough not to be saturated at the peak inductor current.

Output Capacitor Selection

Output capacitors are used to obtain high bandwidth for the output voltage beyond the bandwidth of the converter itself. Usually, the CPU manufacturer recommends a capacitor configuration. Two different kinds of output capacitors are typically used : bulk capacitors closely located next to the inductors, and ceramic output capacitors in close proximity to the load. Latter ones are for mid-frequency decoupling with especially small ESR and ESL values, while the bulk capacitors have to provide enough stored energy to overcome the low frequency bandwidth gap between the regulator and the CPU.

Thermal Considerations

For continuous operation, do not exceed absolute maximum junction temperature. The maximum power dissipation depends on the thermal resistance of the IC package, PCB layout, rate of surrounding airflow, and difference between junction and ambient temperature. The maximum power dissipation can be calculated by the following formula :

$$P_{D(MAX)} = (T_{J(MAX)} - T_A) / \theta_{JA}$$

where $T_{J(MAX)}$ is the maximum junction temperature, T_A is the ambient temperature, and θ_{JA} is the junction to ambient thermal resistance.

For recommended operating condition specifications, the maximum junction temperature is 125°C. The junction to ambient thermal resistance, θ_{JA} , is layout dependent. For WQFN-56L 7x7 packages, the thermal resistance, θ_{JA} , is 31°C/W on a standard JEDEC 51-7 four-layer thermal test board. The maximum power dissipation at $T_A = 25^\circ\text{C}$ can be calculated by the following formula :

$$P_{D(MAX)} = (125^\circ\text{C} - 25^\circ\text{C}) / (31^\circ\text{C/W}) = 3.226\text{W for}$$

WQFN-56L 7x7 package

The maximum power dissipation depends on the operating ambient temperature for fixed $T_{J(MAX)}$ and thermal resistance, θ_{JA} . The derating curve in Figure 26 allows the designer to see the effect of rising ambient temperature on the maximum power dissipation.

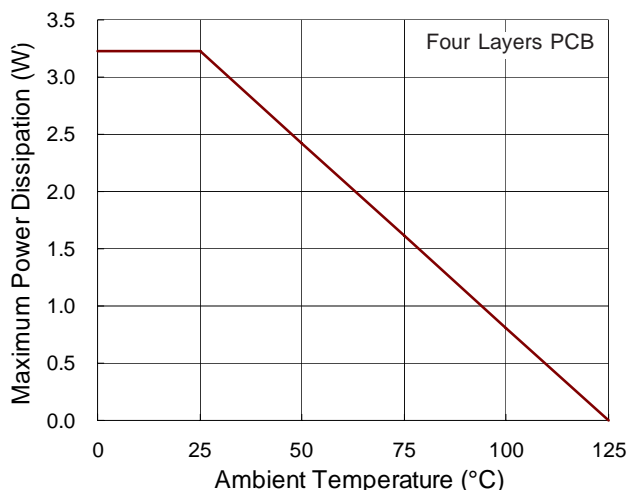

Figure 26. Derating Curve of Maximum Power Dissipation

Layout Considerations

Careful PC board layout is critical to achieve low switching losses and clean, stable operation. The switching power stage requires particular attention. If possible, mount all of the power components on the top side of the board with their ground terminals flushed against one another. Follow these guidelines for optimum PC board layout :

- ▶ Keep the high current paths short, especially at the ground terminals.
- ▶ Keep the power traces and load connections short. This is essential for high efficiency.
- ▶ When trade-offs in trace lengths must be made, it's preferable to let the inductor charging path be longer than the discharging path.
- ▶ Place the current sense component close to the controller. ISENxP and ISENxN connections for current limit and voltage positioning must be made using Kelvin sense connections to guarantee current sense accuracy. The PCB trace from the sense nodes should be paralleled back to the controller.
- ▶ Route high speed switching nodes away from sensitive analog areas (COMP, FB, ISENxP, ISENxN, etc...)

Outline Dimension

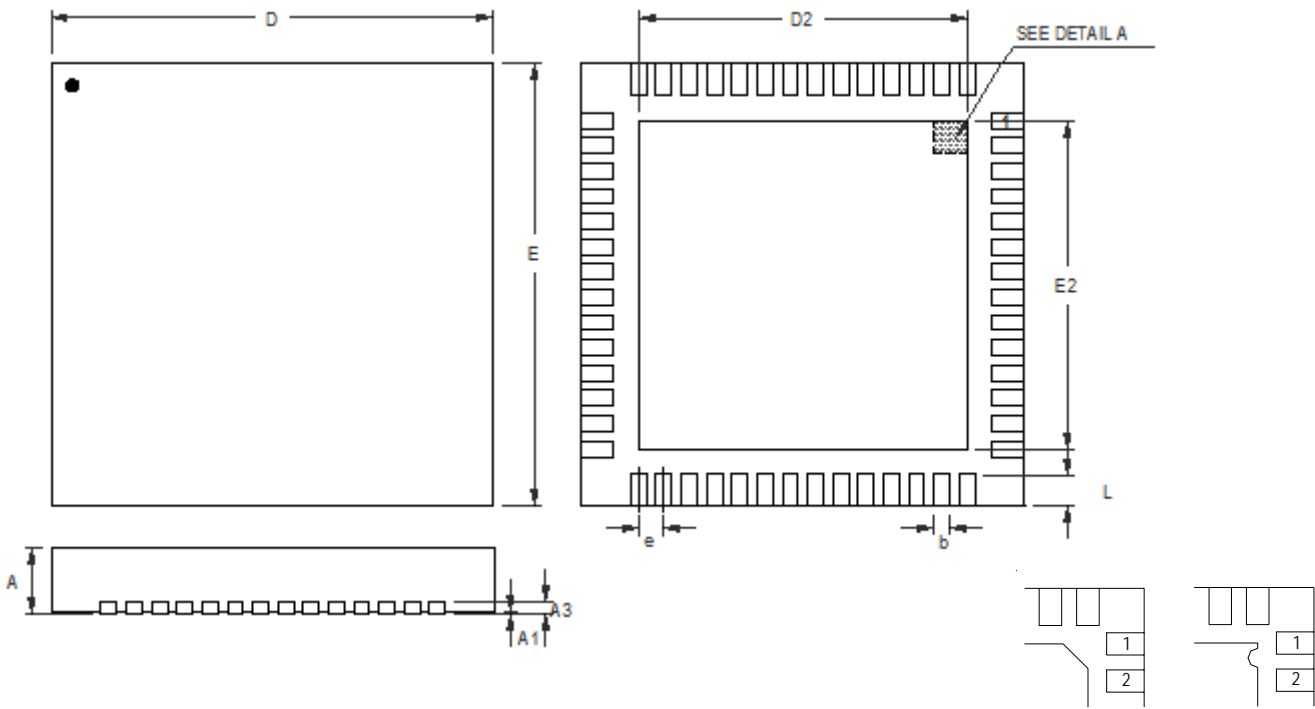

DETAILA

Pin #1 ID and Tie Bar Mark Options

Note : The configuration of the Pin #1 identifier is optional, but must be located within the zone indicated.

Symbol	Dimensions In Millimeters		Dimensions In Inches	
	Min	Max	Min	Max
A	0.700	0.800	0.028	0.031
A1	0.000	0.050	0.000	0.002
A3	0.175	0.250	0.007	0.010
b	0.150	0.250	0.006	0.010
D	6.900	7.100	0.272	0.280
D2	5.150	5.250	0.203	0.207
E	6.900	7.100	0.272	0.280
E2	5.150	5.250	0.203	0.207
e	0.400		0.016	
L	0.350	0.450	0.014	0.018

W-Type 56L QFN 7x7 Package

Richtek Technology Corporation

14F, No. 8, Tai Yuen 1st Street, Chupei City

Hsinchu, Taiwan, R.O.C.

Tel: (8863)5526789

Richtek products are sold by description only. Richtek reserves the right to change the circuitry and/or specifications without notice at any time. Customers should obtain the latest relevant information and data sheets before placing orders and should verify that such information is current and complete. Richtek cannot assume responsibility for use of any circuitry other than circuitry entirely embodied in a Richtek product. Information furnished by Richtek is believed to be accurate and reliable. However, no responsibility is assumed by Richtek or its subsidiaries for its use; nor for any infringements of patents or other rights of third parties which may result from its use. No license is granted by implication or otherwise under any patent or patent rights of Richtek or its subsidiaries.