

PART NUMBER	REV	FIRST USED	POWER UNIT	FEED TYPE	DESCRIPTION
1855214-1	A	122500-1	LEADMAKER	POST FEED	CUTS CARRIER
1855214-2	A	565435-5	BENCH MODEL K	PRE FEED	CUTS CARRIER
1855214-3	A	354500-1	BENCH MODEL G	PRE FEED	CUTS CARRIER
1855214-6	A	122500-1	LEADMAKER	POST FEED	CONTINUOUS CARRIER
7-1855214-7	A	-	-	-	SPARE PARTS

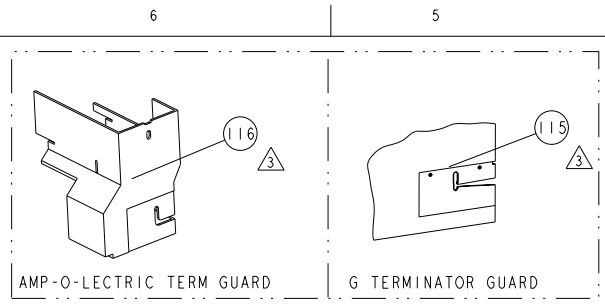

TERMINAL NAME: SNAP ON FEMALE 12.80mm APEX TERMINAL					
TE PN	FCI PN	FCI TERMINAL - FCI CRIMP SPECS			
1949305-1	54001403				
-	-	CRIMP HEIGHT	WIRE SIZE		REF SETTING
-	-	1.60±0.05(1.063±.002)	14AWG		C7
-	-	1.50±0.05(1.059±.002)	16AWG		D3
-	-	-	-		-
-	-	-	-		-
-	-	CRIMP	SIZE	TYPE	RANGE
-	-	WIRE	2.36mm (.093)	F	16-14 AWG
-	-	INSUL	3.05mm (.120)	F	-
WIRE STRIP LENGTH	TERM APPL SPEC	FEED	APPLICATOR INSTRUCTIONS		SET UP GAGE
4.80-5.18	NONE	15.24mm	408-8040		458637-1

LOC	DIST	REVISIONS					
A	66	F	LTN	DESCRIPTION	DATE	BY	APPRO
		A		RELEASED	02NOV2009	BH	BH
		A1		ECR-10-005728	15MAR2010	MY	GB

- 1 RECOMMENDED SPARE PARTS
- 2 GREASE LIGHTLY
- 3 GUARD MUST BE IN PLACE WHEN OPERATING APPLICATOR IN A BENCH MACHINE

**WARNING**  
ON INSTALLATION, SET WIRE DISC TO LARGEST WIRE SIZE SETTING. USE OF SETTINGS BELOW MIN. REQUIRED CRIMP HEIGHT SETTING WILL CAUSE DAMAGE TO CRIMP TOOLING.

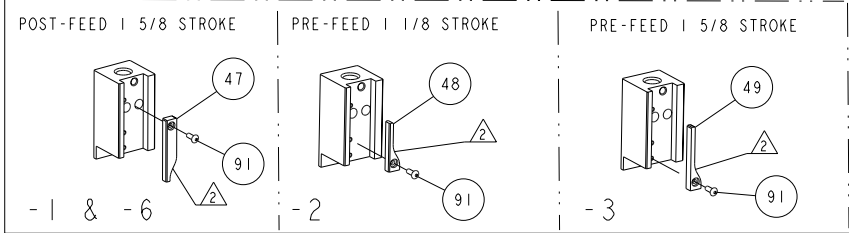
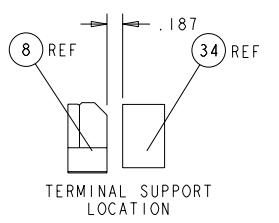
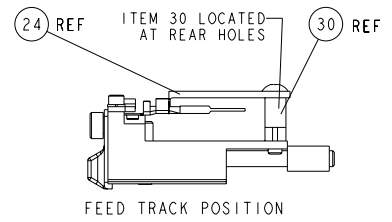
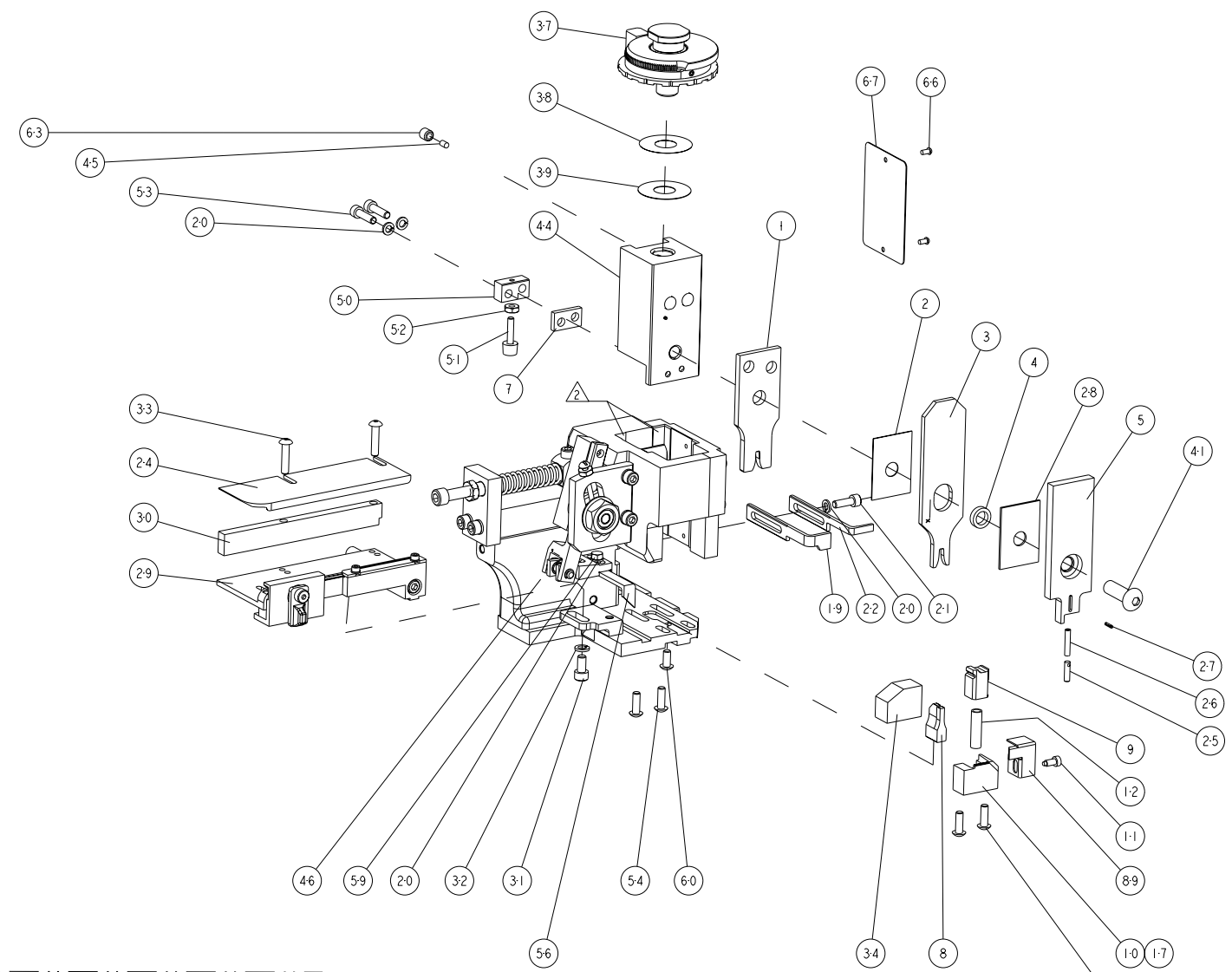

3	-	-	-	REF	-	..	455749-1	GUARD WINDOW	116
3	-	-	-	REF	-	..	679532-1	INSERT, GUARD	115
-	1	1	1	1	-	-	1-21002-7	SCR, BTN SKT HD CAP 6-32 X .375	91
-	1	1	1	1	-	-	318563-1	GUARD, FRONT CHIP	89
-	1	1	1	1	-	-	4088040	SF APPL INST 408-8040	72
-	1	1	1	1	-	-	217238-1	GENERAL INSTRUCTION PKG	71
-	1	1	1	1	-	-	461264-5	PLATE, IDENTIFICATION	67
-	2	2	2	2	-	-	21017-2	SCREW, DRIVE	66
-	1	1	1	1	-	-	21009-2	SCR, SET, SELF LOCKING 1/4-20 X .250	63
-	1	1	1	1	-	-	22733-8	SCR, BHSC, SELF-LOCKING, 8-32 X .375	60
-	1	1	1	1	-	-	2-22603-0	SCR, HEX HD CAP 8-32 X .312	59
-	1	1	1	1	-	-	458537-2	PAWL, FEED	56
-	4	4	4	4	-	-	2-21002-2	SCR, BTN SKT HD CAP 8-32 X .500	54
-	2	2	2	2	-	-	2-21000-8	SCR, SKT HD CAP 8-32 X .625	53
-	1	1	1	1	-	-	21018-5	NUT, HEX, REG 6-32	52
-	1	1	1	1	-	-	811242-2	BUMPER, HOLD DOWN	51
-	1	1	1	1	-	-	690753-1	SPACER, TONKER	50
-	-	-	-	-	..	..	690602-6	CAM, PRE FEED, 1/8	49
-	-	-	-	-	..	..	690602-5	CAM, PRE FEED, 1/16	48
-	-	-	-	-	-	-	690501-4	CAM, POST-FEED 1/8	47
-	-	-	-	-	-	-	459456-1	APPL. BASIC SUB ASSY (SIDE WISE MQCA)	46
-	-	-	-	-	-	-	690191-1	PLUG, NYLON	45
-	-	-	-	-	-	-	455673-1	RAM, SIDE FEED	44
-	-	-	-	-	-	-	7-21002-9	SCR, BTN SKT HD CAP 5/16-24 X 1.00	41
-	-	-	-	-	-	-	690125-1	SHIM SUB-ASSY	39
-	-	-	-	-	-	-	469367-3	SHIM	38
-	-	-	-	-	-	-	879103-2	FINE ADJUST HEAD ASSEMBLY	37
-	-	-	-	-	-	-	3-690786-3	TERMINAL SUPPORT	34
-	2	2	2	2	-	-	2-21002-4	SCR, BTN SKT HD CAP 8-32 X .750	33
-	-	-	-	-	-	-	21024-5	WASHER, SPRG LOCK, REG NO 10	32
-	-	-	-	-	-	-	3-21000-4	SCR, SKT HD CAP 10-32 X .375	31
-	-	-	-	-	-	-	1320908-8	SPACER, STRIP GUIDE	30
-	-	-	-	-	-	-	1633091-7	ASSEMBLY, STRIP GUIDE	29
-	-	-	-	-	-	-	1-455888-0	SPACER, CRIMPER	28
-	-	-	-	-	-	-	21028-2	PIN, SLOTTED SPRING .062 X .250	27
-	-	-	-	-	-	-	22278-7	SPRING, COMPRESSION	26
-	-	-	-	-	-	-	854769-4	HOLDER, INS	25
-	-	-	-	-	-	-	1320928-5	PLATE, STRIP GUIDE	24
-	-	-	-	-	-	-	690472-2	STRIPPER	22
-	-	-	-	-	-	-	2-21000-7	SCR, SKT HD CAP 8-32 X .500	21
-	4	4	4	4	-	-	21024-4	WASHER, SPRG LOCK, REG NO 8	20
-	-	-	-	-	-	-	691353-1	STRIPPER	19
-	-	-	-	-	-	-	679625-1	SHEAR HOLDER, FRONT (NO CUT)	17
-	-	-	-	-	-	-	3-22280-3	SPRING, COMPRESSION	12
-	-	-	-	-	-	-	690461-2	STOP, SHEAR	11
-	-	-	-	-	-	-	1-690459-0	SHEAR HOLDER, FRONT	10
-	-	-	-	-	-	-	462006-6	FLOATING SHEAR, FRONT	9
-	-	-	-	-	-	-	1633535-9	ANVIL, COMBINATION	8
-	-	-	-	-	-	-	240641-5	SPACER	7
-	-	-	-	-	-	-	1-854772-4	DEPRESSOR, SHEAR	5
-	-	-	-	-	-	-	238011-2	BLOCK, CRIMPER SPACER	4
-	-	-	-	-	-	-	6-683453-7	CRIMPER, INSULATION PREMIUM	3
-	-	-	-	-	-	-	455888-4	SPACER, CRIMPER	2
-	-	-	-	-	-	-	5-1673600-2	CRIMPER, WIRE	1

REV	DATE	BY	DESCRIPTION
1	16MAR2007	G. HIGMAN	REVISED
2	16MAR2007	CHE. ELBIN	REVISED
3	16MAR2007	N. DEMING	REVISED

DIMENSIONS: INCHES		TOLERANCES UNLESS OTHERWISE SPECIFIED:	
0 PLC	±.01	1 PLC	±.01
1 PLC	±.01	2 PLC	±.01
2 PLC	±.01	3 PLC	±.01
3 PLC	±.01	4 PLC	±.0001
4 PLC	±.0001	ANGLES	±.0001
MATERIAL:		FINISH:	
NONE		NONE	
APPLICATOR SPEC	SIZE	CAGE CODE	DRAWING NO
NONE	A	00779	1855214
RESTRICTED TO	SCALE	SHEET	REV
CUSTOMER ACCESSIBLE PRODUCTION DRAWING	3:5	1	A1