

# HIP4086 3-phase BLDC Motor Drive Demonstration Board, User's Guide

## Introduction

The HIP4086DEMO1Z is a general purpose 3-phase BLDC motor drive with a microprocessor based controller. Hall effect shaft position sensors are used to control the switching sequence of the three 1/2 bridge outputs. The bridge voltage can vary between 12V and 60V and the maximum summed bridge current is 20A (with sufficient air flow). This motor drive can be used as a design reference for multiple applications including e-bikes, battery powered tools, electric power steering, wheel chairs, or any other application, where a BLDC motor is utilized. Because this demonstration board is primarily intended to highlight the application of the HIP4086 3-phase MOSFET driver with no specific application targeted, the control features are limited to simple functions, such as start/stop, reverse rotation, and braking. Open loop speed control is implemented. More advanced control features, such as torque control, speed regulation and regenerative braking are not implemented because these methods require close integration with the characteristics of the load dynamics.

## Important Note

Because Hall sensor switching logic sequences for BLDC motors are not all the same, this demo board supports most, if not all, variations of sequence logic. Please refer to the sequence charts in "Selecting the Correct Switching Sequence" on page 9 to verify that your desired sequence is implemented. If you require a different sequence for your specific motor application or if you need help identifying the correct switching sequence for your specific motor, please contact Intersil prior to ordering this demo board for possible support for a new switching sequence.

## Specifications

Motor topology	3-phase BLDC motor with Hall sensors
Operating voltage range	15VDC to 60VDC
Maximum bridge current	20A (with sufficient air flow)
Hall sensor bias voltage	5V
PWM switching frequency	20kHz

## Scope

This application note covers the design details of the HIP4086DEMO1Z with a focus on the design implementation of the HIP4086 driver using recommended support circuits.

Also covered, is the design method of the bipolar current sensing feature. Presently, current sensing on this demo board is used only for pulse-by-pulse current limiting. However, an

analog signal proportional to the motor current is available on board as a design reference.

The microcontroller firmware is also provided as a reference but the only support offered by Intersil will be for bug corrections and for adding more switching sequences. Please refer to Microchip for details on the use of the PIC18F2431.

## Physical Layout

The HIP4086DEMO1Z board is 102mm by 81mm. The tallest component is a 470µF capacitor. The total height is 24mm with standoffs or 18.5mm without standoffs. The Hall effect shaft position sensor inputs are miniature terminal blocks and the high current outputs are larger terminal blocks that are rated for 20A.

Four push-buttons are used for reset, brake, reverse, and start/stop functions. An on-board potentiometer is used to adjust the duty cycle of the applied motor voltage or an optional external potentiometer can be connected to a signal terminal block located adjacent to the Hall terminal blocks.

The switching sequence selection dip switch is used for various purposes but the most important function is to select the desired switching sequence. Please refer to the "Setup and Operating Instructions" on page 3 for more information.

For those customers who would like to modify the firmware of the PIC18F2431 microcontroller, an RJ25 connector is provided for easy connection with Microchip firmware development tools (not provided or supported by Intersil).

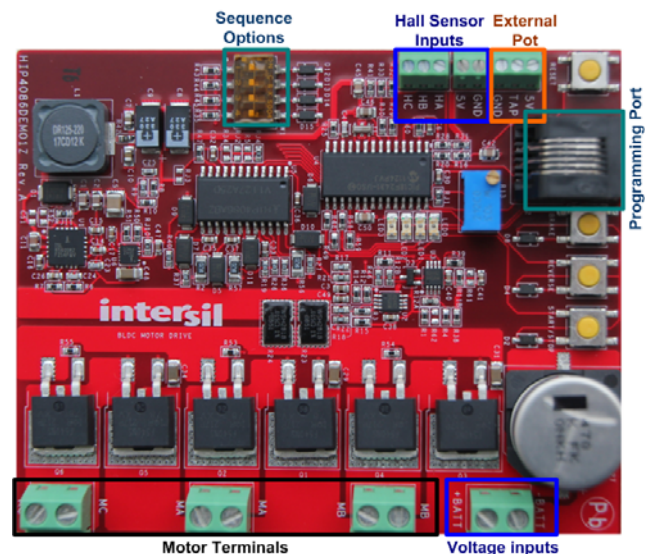

**FIGURE 1. HIP4086DEMO1Z INPUTS AND OUTPUTS**

## Block Diagram

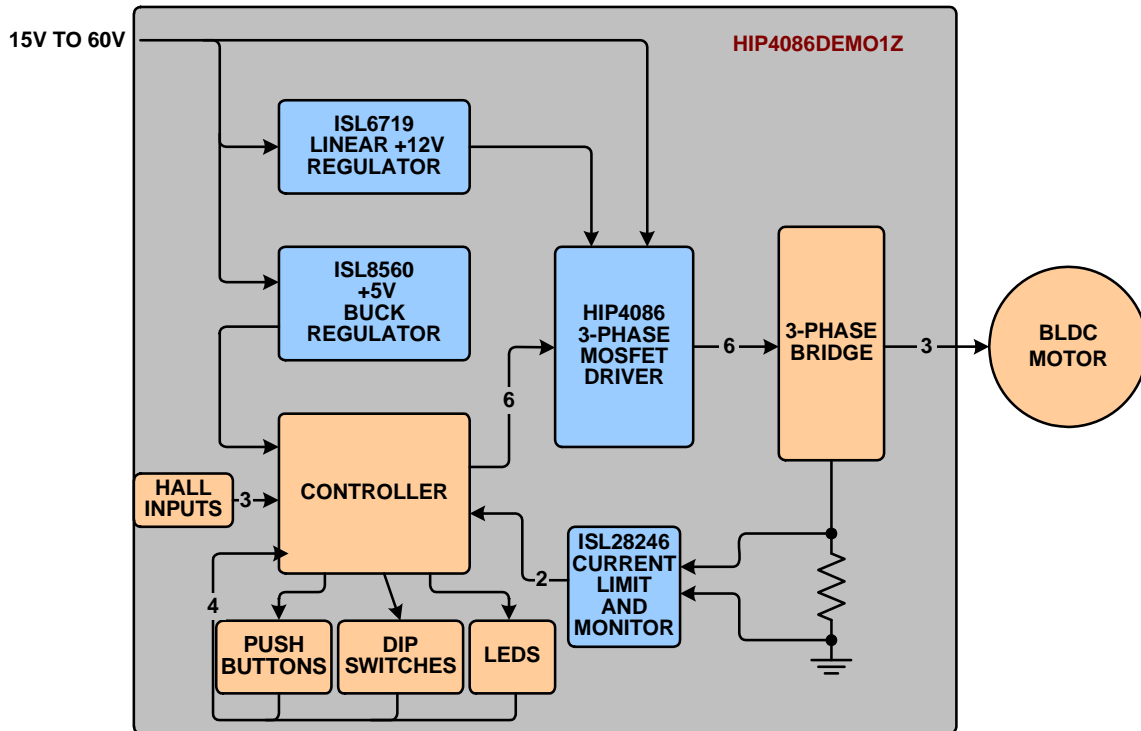

FIGURE 2. HIP4086DEMO1Z BLOCK DIAGRAM

The HIP4086DEMO1Z is composed of six major circuits illustrating the use of several Intersil products.

### Bias Supplies

The ISL8560 is a buck regulator with integrated power FETs that provides +5V bias for the microcontroller, dip switches, push buttons, LEDs, and the current monitor/limit circuits. The ISL6719 is a linear regulator that provides 12V bias for the HIP4086 3-phase MOSFET driver. Please refer to the [ISL8560](#) datasheet or the [ISL6719](#) datasheet for application information.

### HIP4086

The HIP4086, the featured Intersil part, drives 3 bridge pairs of F540NS power FETs with a PWM frequency of 20KHz. Associated with the HIP4086 are the necessary support circuits such as the boot capacitors and boot diodes. Recommended negative voltage clamping diodes on the xHS pins are also provided.

### MicroController

The Hall sensor inputs are decoded by the microcontroller to provide the appropriate switching sequence signals to the HIP4086 to drive the six F540NS bridge FETs that are connected to a 3-phase BLDC motor. In addition to decoding the Hall sensors, the microcontroller also multiplexes the dip switches (for switching sequence options), the push buttons (for various control functions of the motor), and the LED status lights.

The on-board potentiometer (or an optional external pot) is monitored by the microcontroller to provide a duty cycle to the motor that is proportional to the tap voltage of the potentiometer

and varies between 0% and 100% duty cycle. This proportional duty cycle is open loop and is independent of the bridge voltage. Consequently, any motor voltage between 15V and 60V can be used with this demo board.

The microcontroller firmware is provided as a reference but the only support offered by Intersil will be for bug corrections and for adding more switching sequences. All firmware revisions for this demo board can be found on the Intersil website. The firmware revision of your demo board can be determined by referring to the "Test Mode Setup" on page 24.

### Current Sensing/Current Limit

Two ISL28246 low offset, dual op-amps are used for current monitoring and current limiting. One op-amp is configured as a differential amplifier for Kelvin connections across the current sensing resistor. The diff-amp is also biased so that zero bridge current results with an output voltage that is 1/2 of the +5V bias. Consequently, positive bridge currents results with a current monitor signal that is greater than 2.5V (up to ~5V). Negative bridge currents (that occur with regenerative braking) is less than 2.5V (down to a minimum of ~0V). This "bipolar" analog signal can be monitored by the microcontroller for purposes, such as torque control and/or regenerative braking.

The output of the analog differential amplifier is also connected to two op amps configured as outside window comparators for pulse-by-pulse current limits for either positive or negative bridge currents. The OR'ed comparator outputs are sent to the microcontroller for processing.

# Application Note 1829

## 3-phase Bridge

The 3-phase bridge is composed of six F540NS power MOSFETS (100V, 33A). Each FET is driven by one of the six driver outputs of the HIP4086. Dead time is provided by the controller (optionally, dead time can be provided by the HIP4086).

## Related Literature

- [FN4220](#) HIP4086, 80V, 500mA, 3-Phase MOSFET Driver
- [FN6555](#) ISL6719, 100V Linear Bias Supply
- [FN9244](#) ISL8560, DC/DC Power Switching Regulator
- [FN6321](#) ISL28246, 5MHz, Single and Dual Rail-to-Rail Input-Output (RRIO) Op Amps

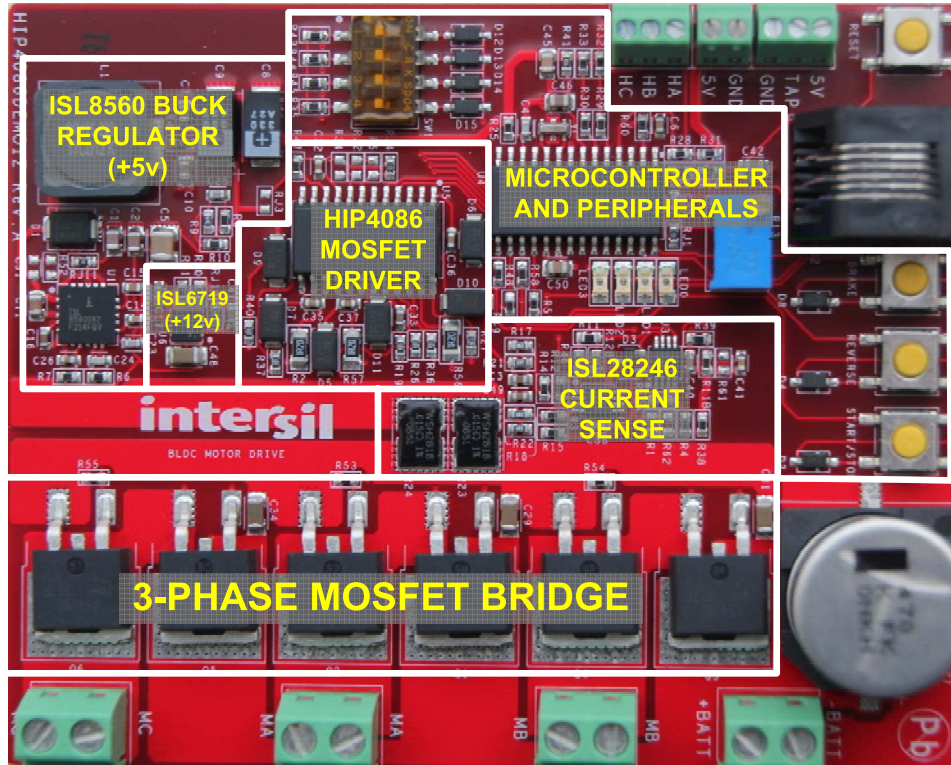

FIGURE 3. MAJOR CIRCUIT LOCATIONS

## Setup and Operating Instructions

### Required and Recommended Lab Equipment

Lab supply (or battery), 15V minimum to 60V absolute maximum. The current rating of the lab supply must have sufficient capacity for the motor being tested. If a battery is the power source, it is highly recommended that an appropriate fuse be used listed as follows:

- Bench fan
- Test motor
- Multichannel oscilloscope, 100 MHz
- Multimeter
- Temperature probe (optional)

**CAUTION:** If the HIP4086DEMO1Z is used for an extended period at high power levels, it may be necessary that a fan be used to keep the temperature of the bridge FETs to less than +85°C (as measured on the heat sink plane).

1. Connect the 3-phase motor leads to the MA, MB, and MC terminal blocks. For high current applications, it is recommended that both terminals of each block be used. It is

also recommended that during initial setup the motor **not** be mechanically loaded.

2. Connect the HALL sensor leads of the motor to the HA, HB, and HC terminals. The +5V bias and ground leads must all be connected.
3. Rotate the R13 potentiometer to the left (CCW) until it clicks. This will set the starting voltage on the motor to a minimum.
4. Setup the dip switch for the correct switching sequence (see the switching sequence tables at the end of this application note).
5. With a lab supply turned off but previously set to the desired bridge voltage, connect the lab supply (or battery) to the +BATT and -BATT terminal block.
6. Ensure that the motor is securely mounted prior to proceeding with the following steps. Also, do not exceed the maximum rated RPM of your motor.
7. Turn on the lab supply. Observe that the four LEDs turn on and off, one after another. This initial flash of the LEDs indicates that power has been applied. After the initial flash, all LEDs will be off. Operation of the motor is now possible. Note that the dip switch options are read at initial turn-on and changing the settings after power is applied will have no effect. As an

# Application Note 1829

alternative to cycling power, the reset push button can be pressed to re-read the dip switch settings.

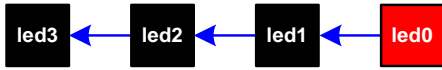

At initial turn on, leds will turn on and off one at a time starting with led0

- Press the Start/Stop push button once. The RUN LED (led0) will blink, indicating that the motor has been started. The motor at this point may not be rotating because minimal voltage is being applied to the motor.



While the motor is rotating, the RUN LED is blinking

- Slowly increase the voltage on the motor by rotating the potentiometer, R13, to the right (CW). At some point the motor will start to rotate slowly. The actual starting voltage is dependent on the specific motor being used.
- If the motor is vibrating back and forth instead of rotating, it is possible that the Hall sensors or the motor leads were not connected correctly. If the correct switching sequence has been selected, all that should be necessary to correct this misbehavior is to swap two of the motors lead (or to swap two of the Hall sensor leads).
- Continue to rotate the pot until the motor is running at a moderate speed of roughly 25%. Do not run the motor with maximum voltage until the setup check-out is completed.
- Press again the START/STOP push button. The motor will free wheel to a stop and the blinking led0 will turn off.



- Press again the START/STOP button. The motor will accelerate to the previous run speed (assuming that the potentiometer was not rotated). The blinking led0 will also turn on.



- While the motor is running, press the REVERSE button. The RUN LED (led0) will turn off and the REVERSE LED (led1) will turn on without blinking. After a short pause while the motor is freewheeling to a stop, the motor will restart rotating in the opposite direction. The RUN LED will be blinking and the REVERSE LED will continue to be on.



- Press again the REVERSE button. As before, the motor will stop. But this time the REVERSE LED will turn off. After a pause, the motor will restart but this time rotating in the forward direction.

- While the motor is running, the motor can be hard braked by pressing the BRAKE push button. The BRAKE LED (LED2) will be on without blinking. When the motor is restarted, the BRAKE LED will turn off.



**CAUTION: The braking method implemented turns on all of the low-side bridge FETs simultaneously. This will force the motor to a very rapid stop. If the motor is loaded, or if the motor is not designed for a rapid stop, mechanical damage to the motor or the load can result. If you are not sure about using this braking method, only apply the brake when the motor speed is relatively slow.**

- If while operating, the motors turns off, and the iLIMIT LED (led3) is blinking, the current limit shut-down has been activated after 255 consecutive pulse-by-pulse current limits. This may happen if the motor speed is accelerated too quickly, or if there is a fault with the motor or connections, or if the motor is stalled.



It is now safe to proceed with testing at higher power levels speeds.

## Theory of Operation

The HIP4086DEMO1Z demonstration board is a general purpose 3-phase BLDC motor controller. Three half bridge power circuits drive the motor as shown in Figure 4.

Three 6 step bridge state logic diagrams, illustrated in Figure 5, are used to drive the motor. The bridge state logic diagrams represents the logic status of the each half bridge but the actual voltage applied to the motor appears much differently. Figure 6 illustrates the bridge status logic vs the actual voltage waveforms applied to each motor lead.

The HIP4086 has 6 driver outputs, AHO, ALO, BHO, BLO, CHO, and CLO, to control the six bridge FETs individually. If the gate drives for both FETs of one half bridge are low, current will not flow in the corresponding motor lead (high impedance or Hi-Z). If the gate drive for the low FET is high and the gate drive for the high FET is low, then the phase node of that half bridge, and the corresponding motor lead, is connected to ground (**Low**). If the low and high gate drives are complementary driven, the phase node can be pulse width modulated (**PWM**) to control the average voltage on that motor lead.

The motor rotation period and the amplitude of the bridge voltage waveforms are modified by the microcontroller to control the speed of the motor. Pulse width modulation is used to modify the amplitude of the voltage waveforms and the motor rotation period is established by the shaft position hall sensors that signal the controller to change the switching sequence. Typical hall sensor logic is illustrated in Figure 5. Each hall logic diagram, HA, HB, and HC, correspond respectively to the bridge state logic diagrams, MA, MB, and MC. For example, the transition of the hall sensor logic, from step 1 to 2, results with the drive waveform transition of **ZLP** to **PLZ** where **P**, **L**, and **Z** define the state of each half bridge.

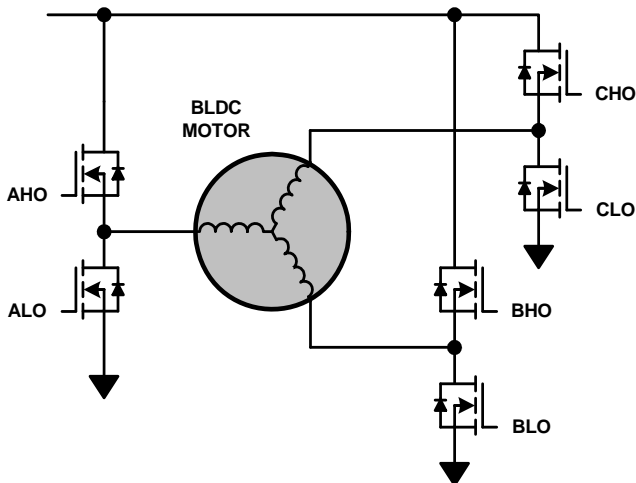

FIGURE 4. BASIC BLDC MOTOR POWER TOPOLOGY

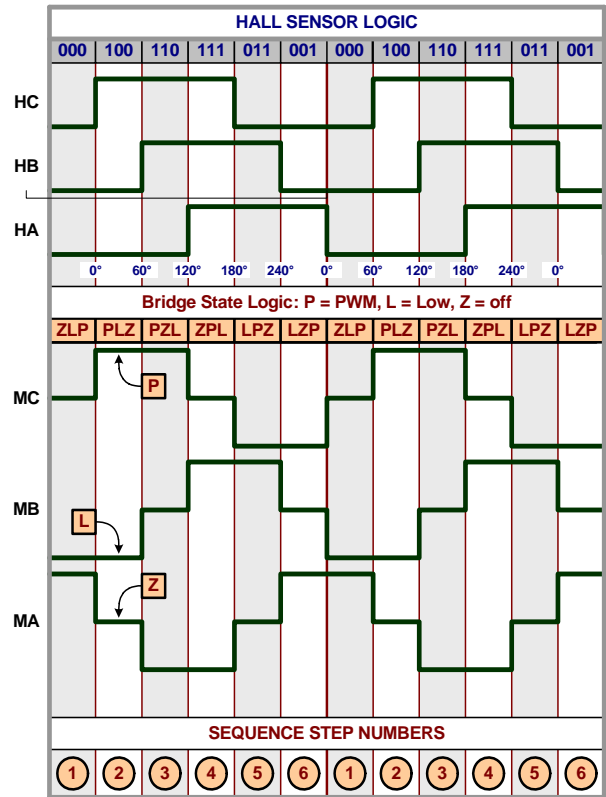

FIGURE 5. HALL SENSOR LOGIC vs BRIDGE STATE LOGIC

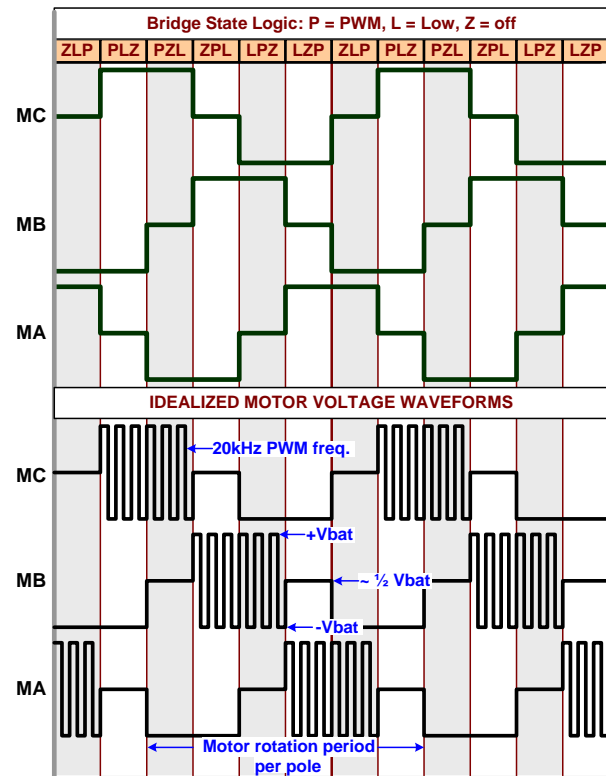

FIGURE 6. BRIDGE STATE LOGIC vs MOTOR VOLTAGE

# Application Note 1829

## Switching Sequence Phase Currents

The following motor winding diagrams illustrate how currents flow in a 3-phase BLDC motor during each switching period of the 6 step voltage waveform. These diagrams are for a very simple motor with only 6 stator poles. Most 3-phase motors have more stator poles (multiples of 6) to reduce torque modulation (cogging) but the principles of operation are the same.

Each phase winding is color coded and black arrows indicate the direction of positive current in that winding for each step. As described in Figure 7, the half bridge state of each motor lead, MA, MB, or MC, is labeled with **P**, **L**, or **Z**. Observe that the active

coils are highlighted. The inactive coils (those with no current) are white.

The dark gray structures are the permanent magnets that are mounted on the light gray rotor. The bold black arrow is the flux vector of the permanent magnets. The bold dark blue arrow is the magnetic flux vector generated by the active coils for each waveform step. The switching step occurs when these two vectors are perpendicular for maximum torque. Notice how the flux vectors are rotating counter clockwise, 60° for each step.

This tutorial for BLDC motors is very fundamental. For more information about a specific motor, please contact the motor manufacturer.

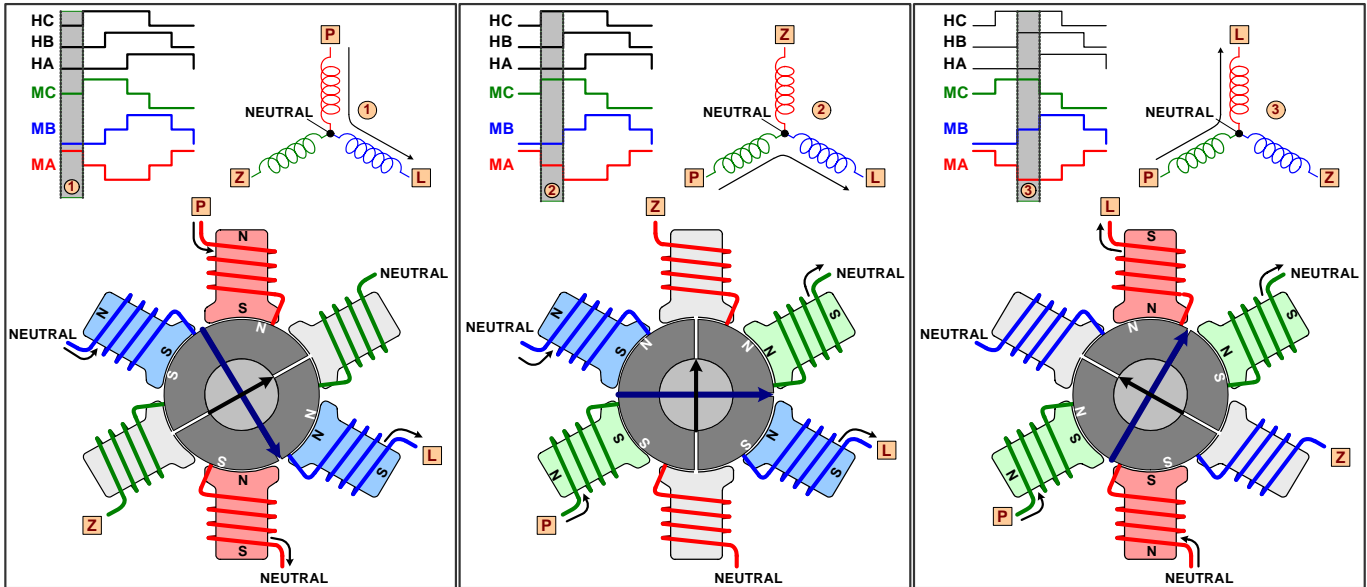

FIGURE 7. SEQUENCE STEPS 1 TO 3

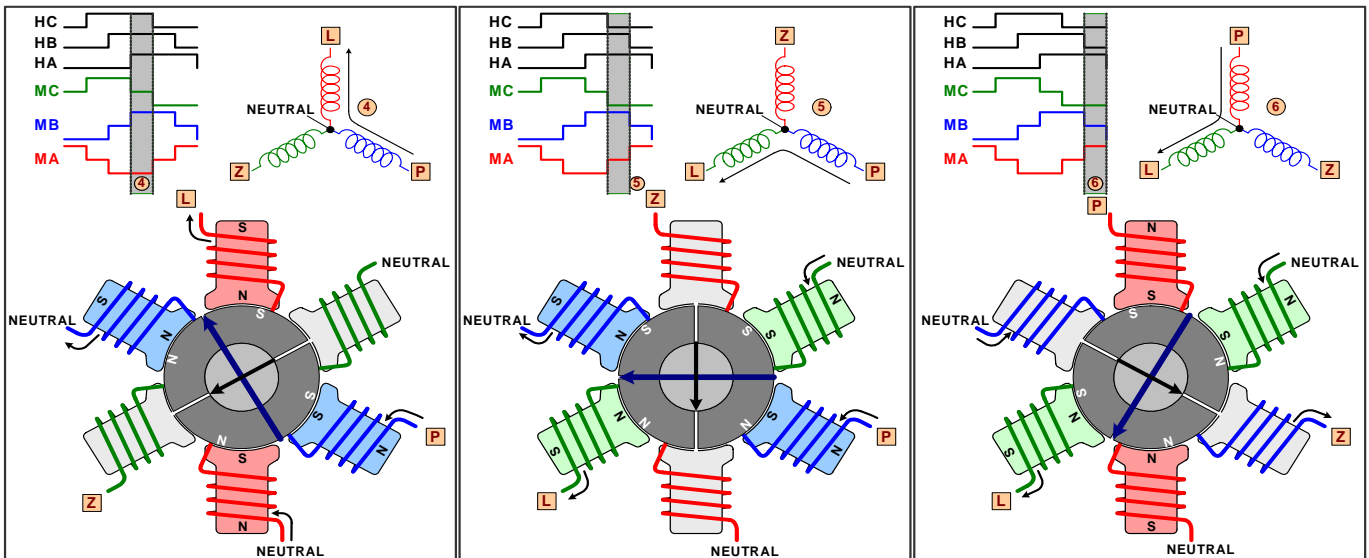

FIGURE 8. SEQUENCE STEPS 4 TO 6

## HIP4086 Circuit Description

In the following discussion, xHI, xLI, xHO, xLO, and xHS is a short hand notation where the x can be replaced with A, B, or C. An “x” pin implies that the reference is applicable to the corresponding A, B, or C pins of the driver.

The simplified schematic of Figure 9 illustrates the three power stages of the motor driver. Each phase is identical in component selection. For specific component values and complete circuit details, please refer to the Bill of Materials (BOM) on page 12 and PCB Layout schematics beginning on page 18.

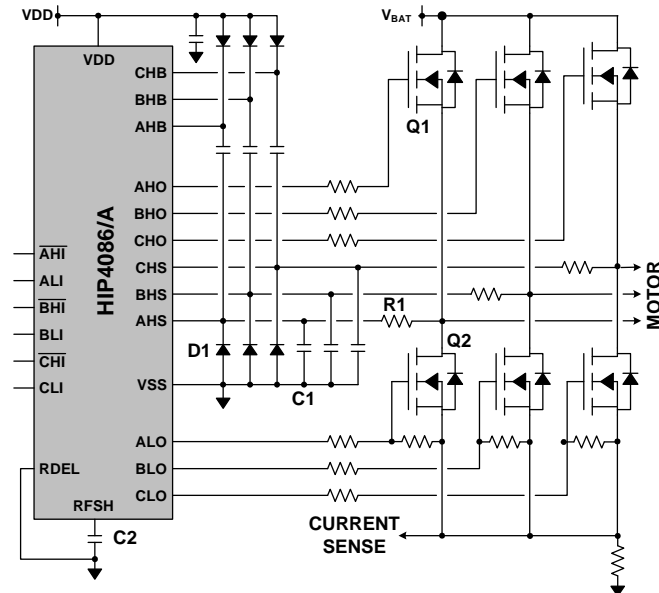

FIGURE 9. SIMPLIFIED 3-PHASE BRIDGE

Series connected gate resistors on each bridge FET are used to reduce the switching speed to help minimize EMI radiating from the power leads to the motor. The user can change these values if desired, keeping in mind that if the gate resistors are made larger, the turn off delays of the FETs will also increase, which may require additional dead time.

All of the xHS pins have recommended external snubber circuits and negative voltage clamps to ensure that safe operating conditions are always maintained over-temperature and loading conditions.

For example, D1 in Figure 9, functions as a negative voltage clamp on the AHS pin. Frequently, circuit designers overlook the negative transients on the xHS pins that occur when the high-side bridge FET turns off. This rapid di/dt transition of the current from Q1 to Q2 develops a negative voltage transient as a result of the parasitic inductance in the low-side FET power current path (see Figure 10).

R1 on the AHS pin is necessary to limit the current in D1 during the dead time because without this resistor, D1 is essentially in parallel with the body diode of Q1. During the dead-time, the commutating negative current in the body diode results with approximately a -1.5V conduction voltage (with large amplitude motor currents). Because the conduction voltage of D1 (~0.6V) is less than the body diode, R1 limits the current that would flow in

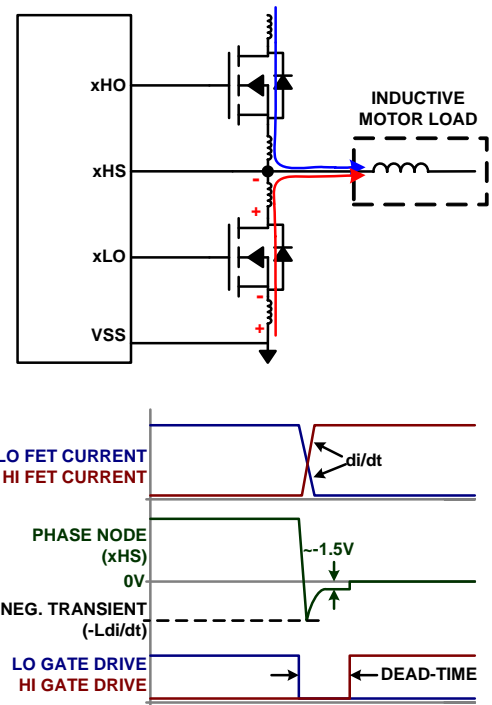

FIGURE 10. NEGATIVE TRANSIENT ON xHS

D1 during the dead-time to safe levels. Note that when the low-side bridge FET is turned on, the negative voltage across the FET is greatly reduced because the conduction voltage of the FET channel is typically much less than the conduction voltage of the body diode. This results with a negative conduction voltage much less than 0.6V and consequently, significant current flows in D1 only during the dead-time.

C1 in parallel with D1 in Figure 9 is used to reduce the dv/dt on the xHS pin and also filters high frequency oscillations that occur on xHS because of parasitic inductance and capacitance on the this node. Clean transitions on xHS ensures fail safe operation of the HIP4086 driver.

As an alternative to these capacitors on the xHS pins, the gate resistors of the bridge FETs can be made larger to lessen the switching speed but at the expense of more switching losses in the bridge FETs.

The HIP4086 has a refresh pulse feature that is used to ensure that the boot caps are biased prior to driving on the high-side drivers. The refresh pulse occurs only once when bias is applied to the driver. The refresh feature of the HIP4086 is not really needed when a programmable controller is used but because this feature cannot be turned off, C32 is used to ensure noise will not be a problem with this pin, which is not only an output pin but also an input.

In this design, the built-in dead time feature of the HIP4086 is not used (because the microcontroller has a programmable dead time function set to 1 $\mu$ s. A hardware option on the board does allow the dead-time function of the HIP4086 to be used if desired. It can be used to further increase the 1 $\mu$ s programmed dead-time if desired.

# Application Note 1829

Please refer to the [HIP4086](#) datasheet for additional application information.

## Current Monitor and Current Limit

There are two current control features in the HIP4086DEMO1Z. A linear current monitor op amp, U2, amplifies the voltage across R23 and R24. This op amp is configured as a true differential amplifier to allow Kelvin connections across the current sensing resistors (see Figure 11). R15 and R3, each 32.4kΩ, have a Thevenin equivalent value that is the parallel value of R15 and R3 (or 1/2 of 32.4kΩ). The Thevenin equivalent voltage also is 1/2 of the bias voltage of 5V. Consequently, the output of the differential amplifier is offset by +2.5V (see Figure 12).

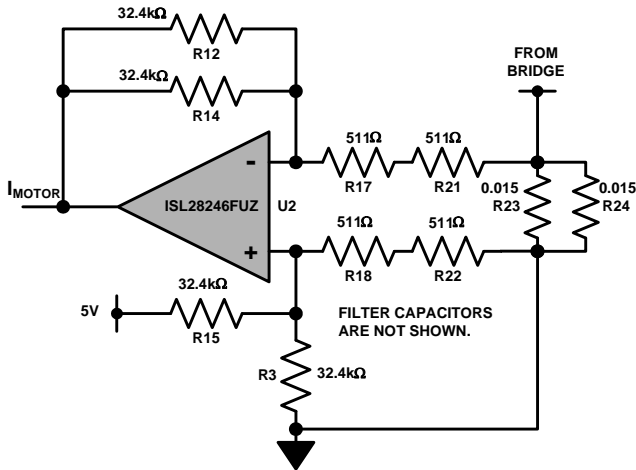
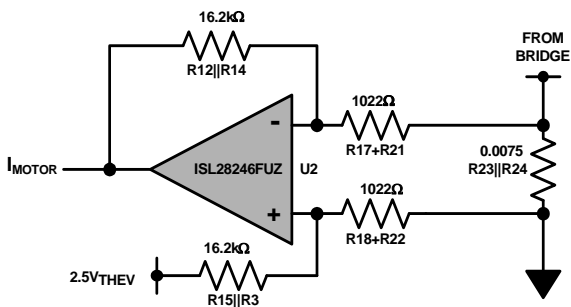

FIGURE 11. DIFFERENTIAL CURRENT MONITOR AMPLIFIER



Note that resistors labeled Rx||Ry represent a parallel equivalent resistor of Rx and Ry. Rx+Ry represents the series combination of Rx and Ry.

FIGURE 12. THEVENIN EQUIVALENT DIFFERENTIAL AMPLIFIER

The current monitor output,  $I_{MOTOR}$ , digitized by the microcontroller, can be used to control the torque of the motor or to limit the battery recharging current during regenerative braking. Because of the offset voltage on the current monitor output, signals above 2.5VDC represents positive motor current and signals less than 2.5VDC represent negative motor current. (Note that this hardware feature is provided for customer use but is not implemented in the microcontroller firmware.)

The output voltage of the differential amplifier is:

$$V_{outCS} = \frac{[(R12 || R14) / (R17+R21)] \times I_M \times (R23 || R24) + R3 / (R3+R15) \times 5V}{(EQ. 1)}$$

where  $I_M$  is the bridge current (motor current),  $R12 || R14 = R15 || R3$ , and  $(R17+R21) = (R18+R22)$  (as required for the differential amp topology).

Using the default values of the HIP4086DEMO1Z:

$$V_{outCS} = [(16.2k\Omega)/(1022)] \times I_m \times (0.0075) + 32.4k\Omega/(64.8k\Omega) \times 5V$$

or

$$V_{outCS} = 0.119 \times I_M + 2.5V$$

(EQ. 2)

For 20A,  $V_{outCS} = 4.878V$ . For -20A,  $V_{outCS} = 0.122V$ .

The  $I_{motor}$  signal is monitored by two comparators (see Figure 13). The output of the upper U3 comparator is biased to go low when the motor current > 20A. Conversely, the output of the lower comparator is biased to go low when the motor current is ≤ 20A.

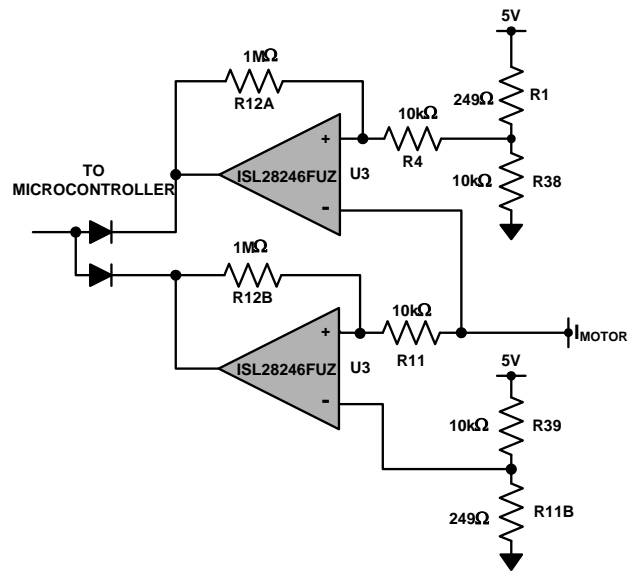

FIGURE 13. PULSE-BY-PULSE CURRENT LIMIT COMPARATORS

The OR'ed outputs of these two comparators is monitored by the microcontroller. Pulse-by-pulse current limiting is provided on each negative transition. After 256 consecutive pulse limits, all the bridge FETs are permanently turned off and the current limit alarm LED (led3) is turned on.

There are two different methods to change the pulse-by-pulse current limit. The easiest method is to change the value of the current sensing resistors R23 and R24. For example, removing R24 halves the pulse by pulse current limit to ± 10A while not affecting the full scale  $I_{motor}$  output signal.

Equation 3 calculates the value of the current sensing resistors to set the pulse-by-pulse current limit at the desired level without changing the full scale output voltage swing of the  $I_{MOTOR}$  signal.



## Application Note 1829

This equation assumes that the only change made to the HIP4086DEMO1Z is modifying the values of the current sensing resistors R23 and R24.

$$R23 \parallel R24 = 4.878V - 2.5V \times 1.022k\Omega / (16.2k\Omega \times I_m) \quad (\text{EQ. 3})$$

For example: for  $I_{LIMIT} = \pm 5A$ ,

$$R23 \parallel R24 = 4.878V - 2.5V \times 1.022k\Omega / (16.2k\Omega \times 5A)$$
$$R23 \parallel R24 = 0.030\Omega$$

An alternative method for changing the pulse-by-pulse current limit is to modify the threshold bias voltages on the comparators. This option is only recommended if appropriate small value resistors for current sensing are not readily available for lab evaluation of the HIP4086DEMO1Z. Note that the full scale output swing of the current diff amp will not be realized with this method.

The threshold bias resistors for the positive current limit are R1 and R38. R39 and R11B are for the negative current limit. The required threshold is determined by Equation 2 for the desired  $I_m$  value. For example, the  $V_{outCS}$  value for pulse-by-pulse current limit at 5A is:

$$V_{outCS} = 0.119 \times 5A + 2.5V = 3.095V$$

Equation 4 sets the positive current limit bias voltage.

$$R1 = 5V \times R38 / (0.119 \times I_m + 2.5V) - R38 \quad (\text{EQ. 4})$$

For pulse-by-pulse positive current limit = 5A and  $R38 = 10k\Omega$ ,

$$R1 = 6.155k\Omega$$

Equation 5 sets the negative current limit bias voltage.

$$R11B = R39 \times (0.119 \times I_m + 2.5V) / (2.5 - 0.119 \times I_m) \quad (\text{EQ. 5})$$

For pulse-by-pulse positive current limit = -5A and  $R39 = 10k\Omega$ ,  
 $R11B = 6.155k\Omega$ .

In the previous examples both the positive and negative current limit value are equal in absolute values. It is acceptable to have different limits for the positive and negative values.

### Selecting the Correct Switching Sequence

In the discussion describing the operation of a BLDC motor, a specific hall logic pattern was used in Figure 5. Unfortunately, not all BLDC motors use this logic pattern. In all cases, the three hall signals are phase shifted by  $60^\circ$  but the logic polarity can be different. Also, because the  $0^\circ$  start position is not standardized, two rotation cycles are illustrated so that any start position can be identified.

The following charts define all possible combinations of hall logic. It is necessary that the hall sensor logic that matches your motor is selected by correctly setting the dip switch prior to applying power to the HIP4086DEMO1Z. Known specific motor part numbers are labeled in green boxes (see Figure 14).

# Application Note 1829

Dip switch positions hall sensor logic options are defined by the blue boxes: **0011**

dip switch position numbers → 4 3 2 1

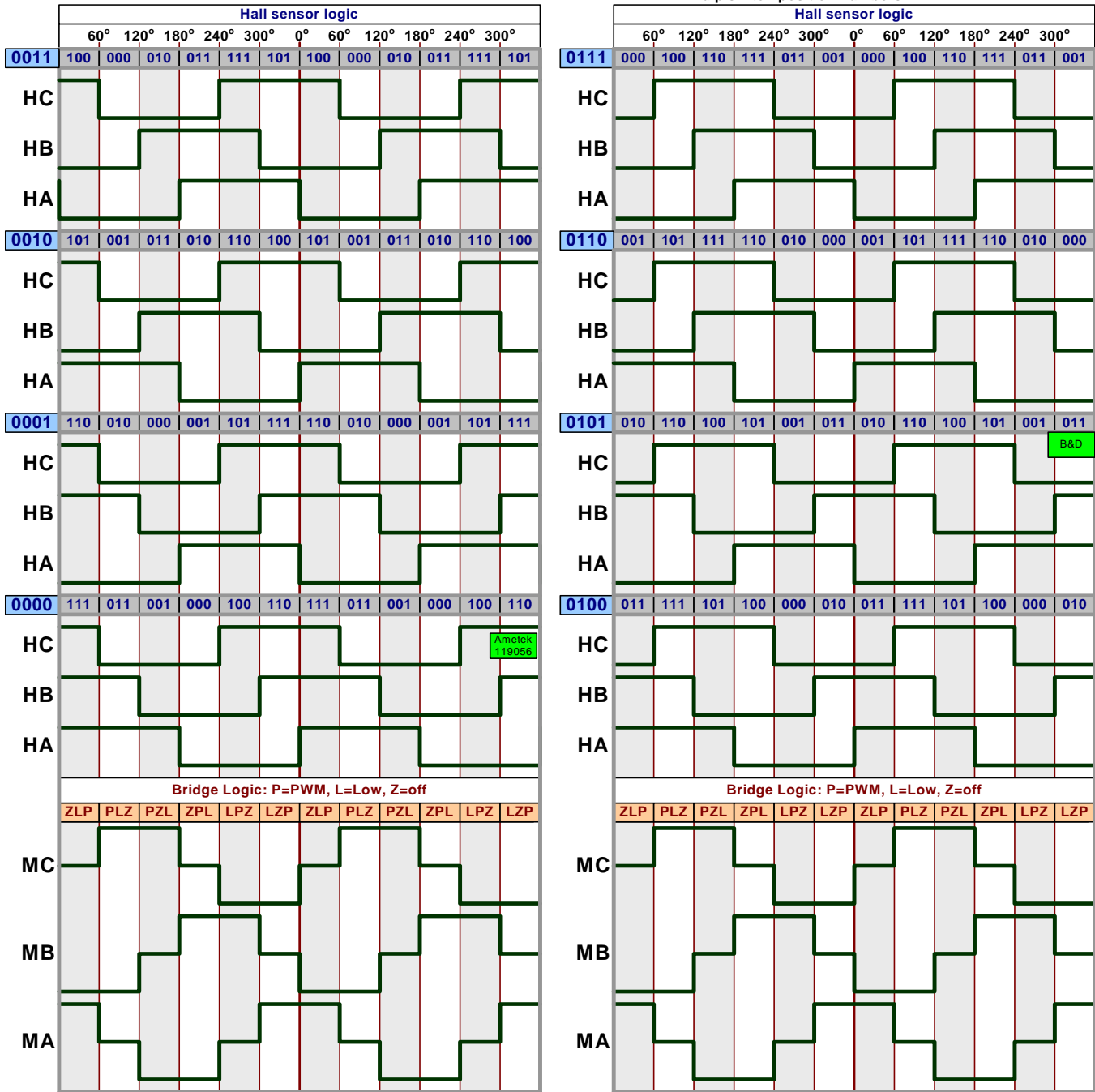

FIGURE 14. HALL LOGIC OPTIONS, FIRST CHART

# Application Note 1829

## Selecting the Correct Switching Sequence

Notice that the dip switch settings for these Hall sensor logic charts (Figure 15) are the same as Figure 14. This is not an error.

Dip switch positions hall sensor logic options are defined by the blue boxes: **0011**

dip switch position numbers → 4 3 2 1

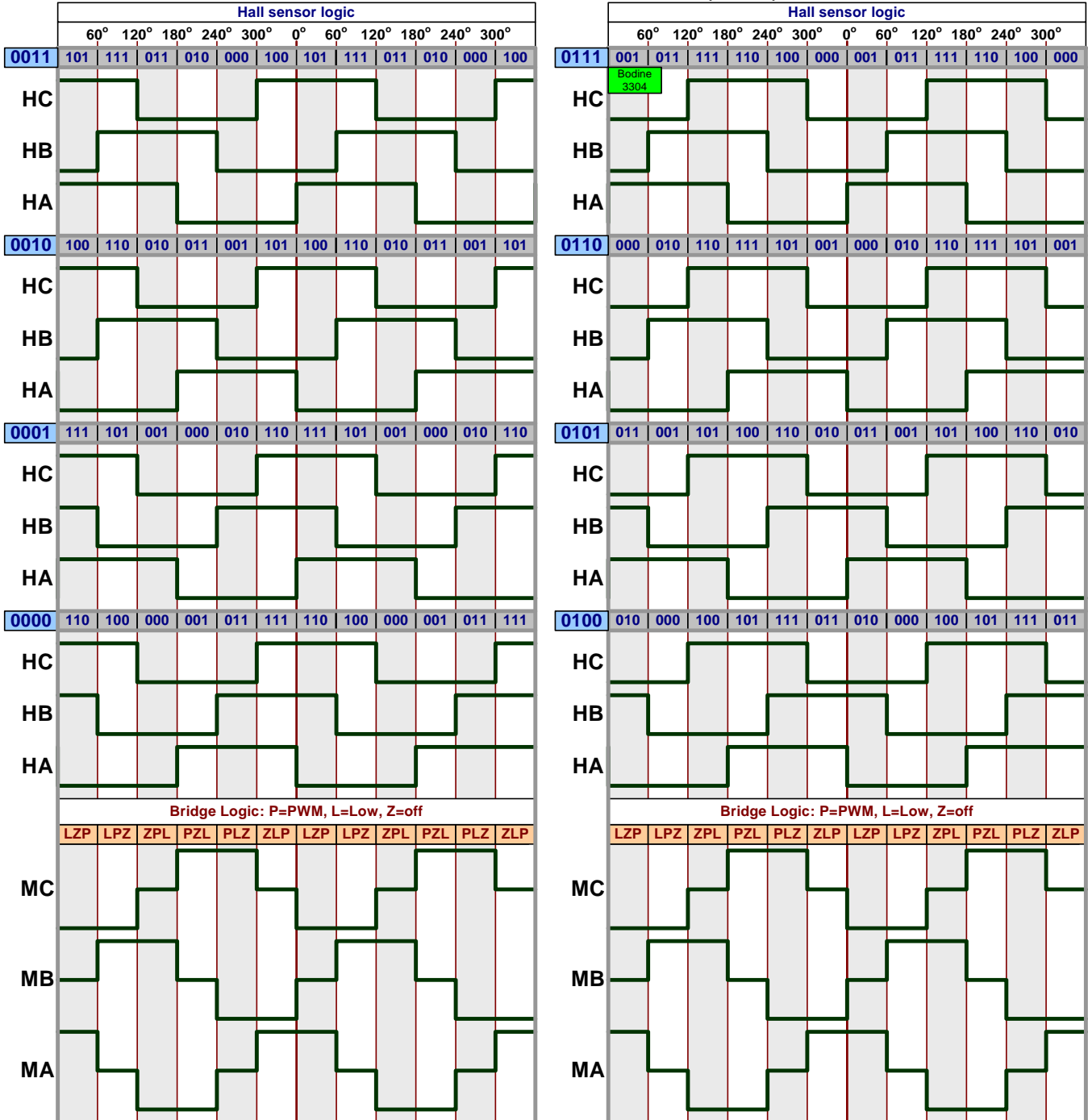

FIGURE 15. HALL LOGIC OPTIONS, SECOND CHART

# Bill of Materials, Rev A

PART NUMBER	REF DES	QTY	VALUE	TOL (%)	VOLTAGE	POWER	PACKAGE TYPE	JEDEC TYPE	MANUFACTURER	DESCRIPTION
10TPE330M	C8, C9	2	330µF	10	10V		SMD	CAP_7343	SANYO-POSCAP	TPE SERIES LOW ESR PRODUCTS CAP
1725656	TB3	1					2MNT	CON_TERM_MPT_2POS	PHOENIX-CONTACT	100 Mil Micro-Pitch Terminal Block
1725669	TB1,TB2	2					3MNT	CON_TERM_MPT_3POS	PHOENIX-CONTACT	100 Mil Micro-Pitch Terminal Block
1729018	TB4-TB7	4					2	CON_TERM_MKDSN_2POS	PHOENIX-CONTACT	200 Mil PCB Connector Terminal Block
1N4148W-7-F	D2, D4, D8, D12-D15	7					SOD	SOD123	DIODES	Fast Switching Diode (RoHS COMPLIANT)
3299W-1-103-LF	R13	1	10kΩ	10		1/2W	RADIAL	RES_POT_3299W	BOURNS	TRIMMER POTENTIOMETER (RoHS COMPLIANT)
555165-1	J2	1					6M2	CON_JACK_555165-1	TYCO	Phone Jack Connector
597-3111-402	LED0-LED3	4					SMD	DIA_LED1206	Dialight	Surface Mount Red LED
B280	D1	1					SMD2	DIO_SMB	DIODES	2A 80V SCHOTTKY BARRIER RECTIFIER
B3S-1002	BRAKE, RESET, REVERSE, START/STOP	4					SMD	SW_B3S-1002	OMRON	Momentary Pushbutton Tactile SMT Switch
BAT54A	D3	1					COMMON-ANODE	SOT23	DIODES	30V SCHOTTKY DIODE
C0805C106K8PACTU	C7, C10	2	10µF	10	10V		805	CAP_0805	KEMET	MULTILAYER CAP
C1608X7R1C105K	C16, C33, C47	3	1µF	10	16V		603	CAP_0603	TDK	MULTILAYER CAP
C1608X7R1H104K	C15	1	0.1µF	10	50V		603	CAP_0603	TDK	MULTILAYER CAP
C3225X7R2A105M	C5	1	1µF	20	100V		1210	CAP_1210	TDK	Ceramic Chip Cap
CSTCE10M5G55	Y1	1					SMD	CSTCE12M	MURATA	10MHz CERALOCK Resonator
DR125-220-R	L1	1	22.0µH	20		4.71A	SMD	IND_DR125	COOPER-BUSSMANN	High Power Density Shielded Inductor
EEVFK1K471M	C27	1	470µF	20	80V		SMD	CAPAE_708X650	PANASONIC	Aluminum Elect SMD Cap
ES1B	D5-D7, D9-D11	6					DO214	DO214_AC	FAIRCHILD	1A 150V Fast Rectifier Diode
GRM21BR71C475KA73L	C42, C45, C46, C50	4	4.7µF	10	16V		805	CAP_0805	MURATA	CERAMIC CAP
H1045-00101-25V10	C4	1	100PF	10	25V		603	CAP_0603	GENERIC	MULTILAYER CAP
H1045-00101-50V10	C23, C25	2	100PF	10	50V		603	CAP_0603	GENERIC	MULTILAYER CAP
H1045-00103-50V10	C14, C30, C41	3	0.01µF	10	50V		603	CAP_0603	GENERIC	Multilayer Cap

# Bill of Materials, Rev A (Continued)

PART NUMBER	REF DES	QTY	VALUE	TOL. (%)	VOLTAGE	POWER	PACKAGE TYPE	JEDEC TYPE	MANUFACTURER	DESCRIPTION
H1045-00104-25V10	C38, C40	2	0.1 $\mu$ F	10	25V		603	CAP_0603	GENERIC	Multilayer Cap
H1045-00221-50V10	C17	1	220pF	10	50V		603	CAP_0603	GENERIC	Multilayer Cap
H1045-00224-16V10	C35-C37	3	0.22 $\mu$ F	10	16V		603	CAP_0603	GENERIC	Multilayer Cap
H1045-00391-50V10	C24	1	390pF	10	50V		603	CAP_0603	GENERIC	Multilayer Cap
H1045-00471-100V10	C26	1	470pF	10	100V		603	CAP_0603	GENERIC	Multilayer Cap
H1045-00471-50V10	C32	1	470pF	10	50V		603	CAP_0603	GENERIC	Multilayer Cap
H1045-00472-50V10	C3, C49	2	4700pF	10	50V		603	CAP_0603	GENERIC	Multilayer Cap
H1045-00473-25V10	C6	1	0.047 $\mu$ F	10	25V		603	CAP_0603	GENERIC	Multilayer Cap
H1045-OPEN	C51	1	OPEN	5	OPEN		603	CAP_0603	GENERIC	Multilayer Cap
H1046-00104-100V10	C1, C2, C11	3	0.1 $\mu$ F	10	100V		805	CAP_0805	GENERIC	Multilayer Cap
H1065-00105-100V10	C29, C31, C34, C48	4	1 $\mu$ F	10	100V		1206	CAP_1206	GENERIC	Multilayer Cap
H2505-DNP-DNP-1	R5, R34, R52, R61, R62	5	DNP	1		DNP	603	RES_0603	GENERIC	Metal Film Chip Resistor (Do Not Populate)
H2505-DNP-DNP-R1	RJ2, RJ3	2	DNP	0.10		DNP	603	RES_0603	GENERIC	Metal Film Chip Resistor (Do Not Populate)
H2511-00330-1/16W5	R19, R26, R27, R36, R37, R40	6	33	5		1/16W	603	RES_0603	GENERIC	Thick Film Chip Resistor
H2511-00R00-1/16W	RJ1	1	0	0		1/16W	603	RES_0603	GENERIC	Thick Film Chip Resistor
H2511-00R00-1/16W1	R42, RJ4, RJ10, RJ11	4	0	1		1/16W	603	RES_0603	GENERIC	Thick Film Chip Resistor
H2511-01000-1/16W1	R46	1	100	1		1/16W	603	RES_0603	GENERIC	Thick Film Chip Resistor
H2511-01001-1/16W1	R47-R49, R51, R58-R60	7	1k $\Omega$	1		1/16W	603	RES_0603	GENERIC	Thick Film Chip Resistor
H2511-01002-1/16W1	R16, R25, R28-R33, R35, R38, R39, R43-R45, R4, R11	16	10k $\Omega$	1		1/16W	603	RES_0603	GENERIC	Thick Film Chip Resistor
H2511-01004-1/16W1	R12A, R12B	2	1M $\Omega$	1		1/16W	603	RES_0603	GENERIC	Thick Film Chip Resistor
H2511-02490-1/16W1	R1, R11B	2	249 $\Omega$	1		1/16W	603	RES_0603	GENERIC	Thick Film Chip Resistor
H2511-01622-1/16W1	R10	1	16.2k $\Omega$	1		1/16W	603	RES_0603	GENERIC	Thick Film Chip Resistor
H2511-02001-1/16W1	R20	1	2k $\Omega$	1		1/16W	603	RES_0603	GENERIC	Thick Film Chip Resistor
H2511-02002-1/16W1	R7, R53-R55	4	20k $\Omega$	1		1/16W	603	RES_0603	GENERIC	Thick Film Chip Resistor
H2511-03013-1/16W1	R6	1	301k $\Omega$	1		1/16W	603	RES_0603	GENERIC	Thick Film Chip Resistor
H2511-03242-1/16W1	R3, R12, R14, R15	4	32.4k $\Omega$	1		1/16W	603	RES_0603	GENERIC	Thick Film Chip Resistor

# Bill of Materials, Rev A (Continued)

PART NUMBER	REF DES	QTY	VALUE	TOL. (%)	VOLTAGE	POWER	PACKAGE TYPE	JEDEC TYPE	MANUFACTURER	DESCRIPTION
H2511-04700-1/16W1	R41	1	470Ω	1		1/16W	603	RES_0603	GENERIC	Thick Film Chip Resistor
H2511-05110-1/16W1	R17, R18, R21, R22	4	511Ω	1		1/16W	603	RES_0603	GENERIC	Thick Film Chip Resistor
H2511-05112-1/16W1	R9	1	51.1kΩ	1		1/16W	603	RES_0603	GENERIC	Thick Film Chip Resistor
H2511-05621-1/16W1	R8	1	5.62kΩ	1		1/16W	603	RES_0603	GENERIC	Thick Film Chip Resistor
H2511-07151-1/16W1	R50	1	7.15kΩ	1		1/16W	603	RES_0603	GENERIC	Thick Film Chip Resistor
H2513-001R2-1/8W1	R2, R56, R57	3	1.2Ω	1		1/8W	1206	RES_1206	GENERIC	Thick Film Chip Resistor
HIP4086ABZ	U5	1					SOIC	SOIC24_300_50	INTERSIL	Three Phasre Driver 80v 0.5A
IRFS4710	Q1-Q6	6					D2PAK	D2PAK	IR	N-Channel 100V 75A HEXFET Power MOSFET
ISL28246FUZ	U2, U3	2					MSOP	MSOP8_118_256	LINEAR	DUAL RAIL TO RAIL OUTPUT AMPLIFIER (Pb-Free)
ISL6719ARZ	U6	1					DFN	DFN9_118X118_197_EP	INTERSIL	100V Linear Regulator
ISL8560IRZ	U1	1					20QFN	QFN20_236X236_315_EP	INTERSIL	2A DC/DC POWER SWITCHING REGULATOR
PIC18F2431S0	U4	1					SOIC	SOIC28_300_50V2	Microchip	Flash Microcontroller
SD04H0SK	SW1	1					SMT	SD04H0SK	C&K	SD Series Low Profile DIP Switch 4 Pos SPST
WSH2818R0150FE	R23, R24	2	0.015Ω	1		5W	2818	RES_WSH2818	VISHAY	SURFACE MOUNT POWER METAL STRIP RESISTOR
TOTAL		157								

# HIP4086DEM01Z Board Schematics

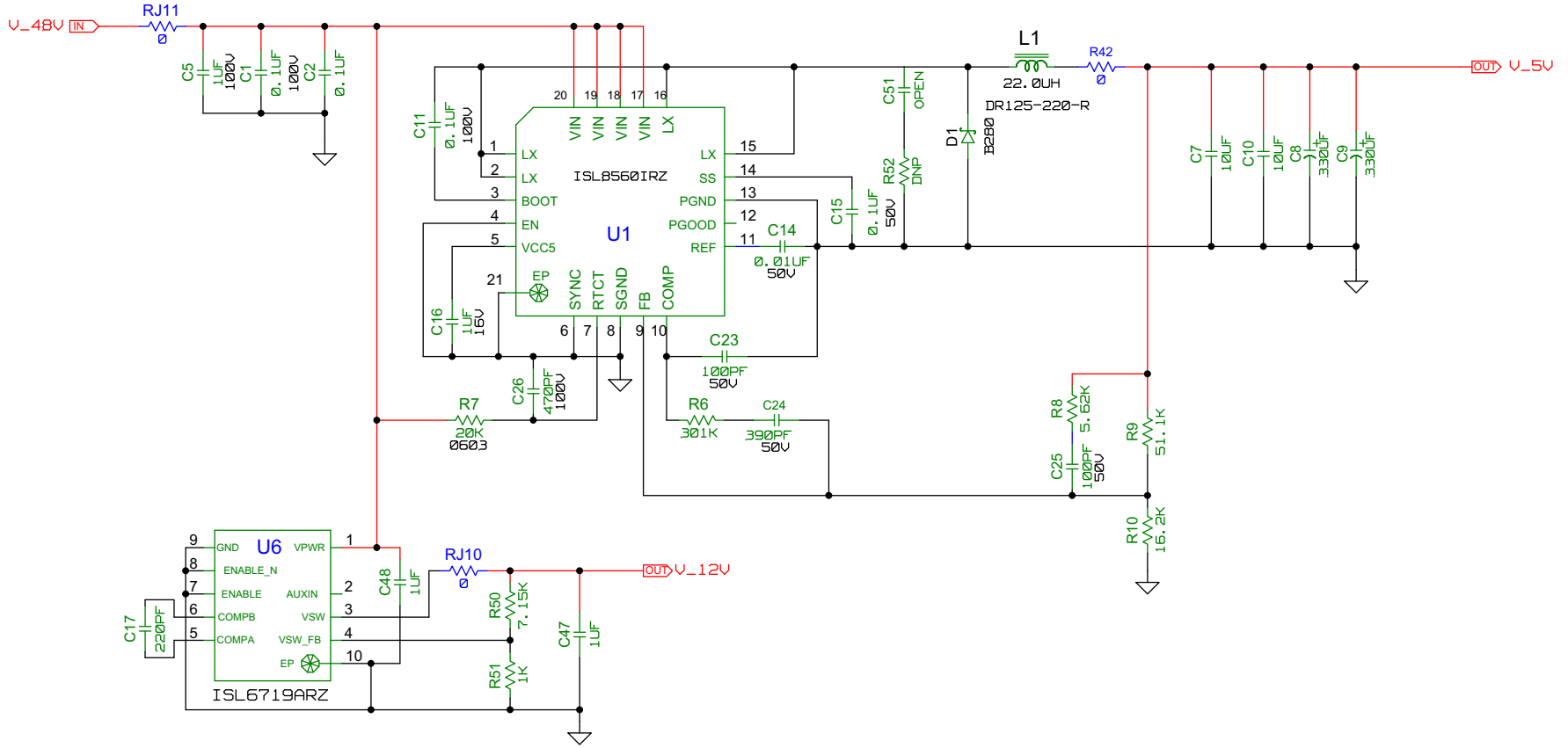

FIGURE 16. BIAS SUPPLIES

# HIP4086DEMO1Z Board Schematics (Continued)

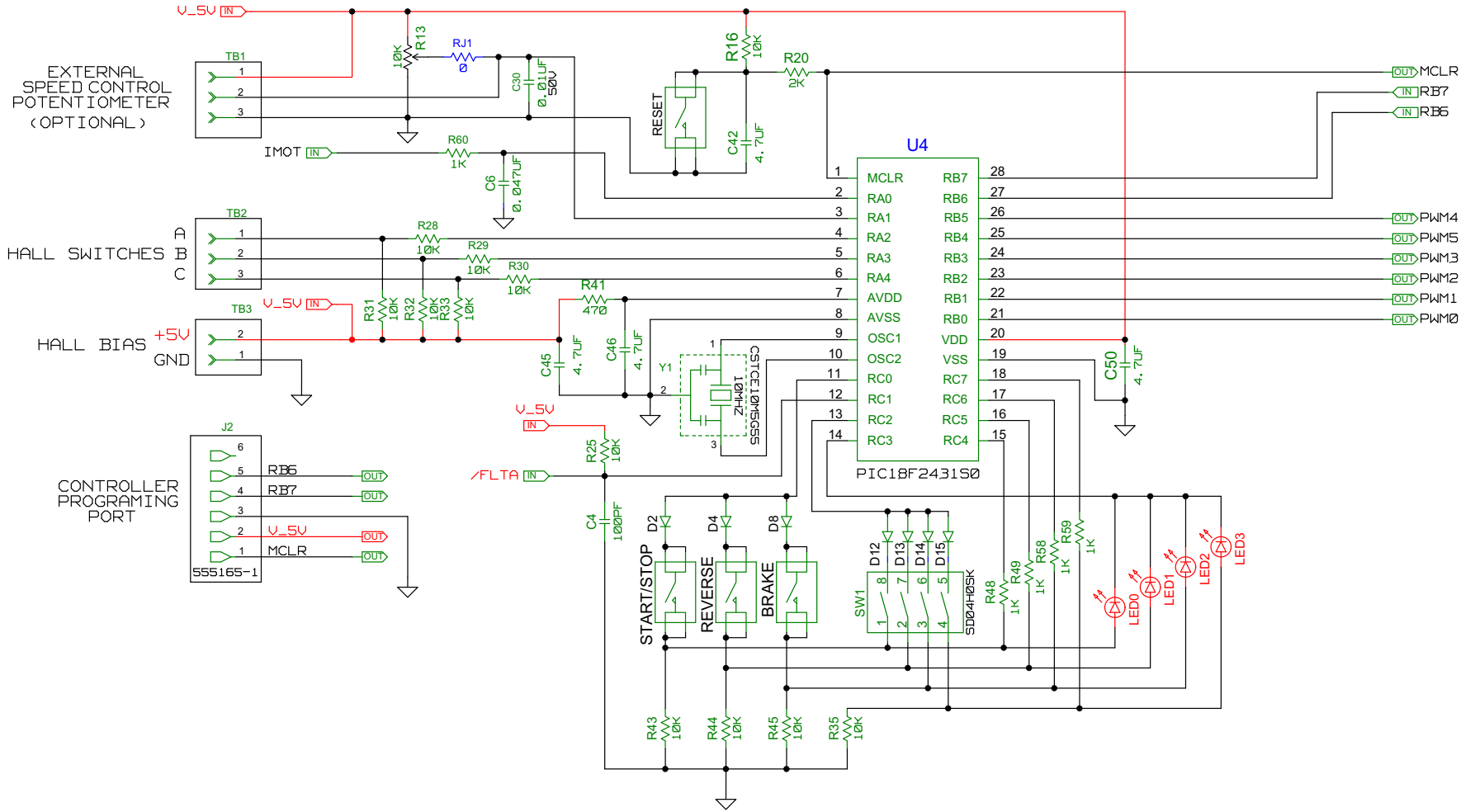

FIGURE 17. CONTROLLER



# HIP4086DEMO1Z Board Schematics (Continued)

FOR NO DEAD TIME DELAYS:  
RJ4= 0 OHM, R5 = OPEN.  
FOR DEAD TIME DELAYS:  
RJ4= OPEN, R5=10K...100K.

TO DISABLE BRIDGE  
DRIVER WHILE TROUBLE-  
SHOOTING CODE:  
RJ3 = 0 OHM

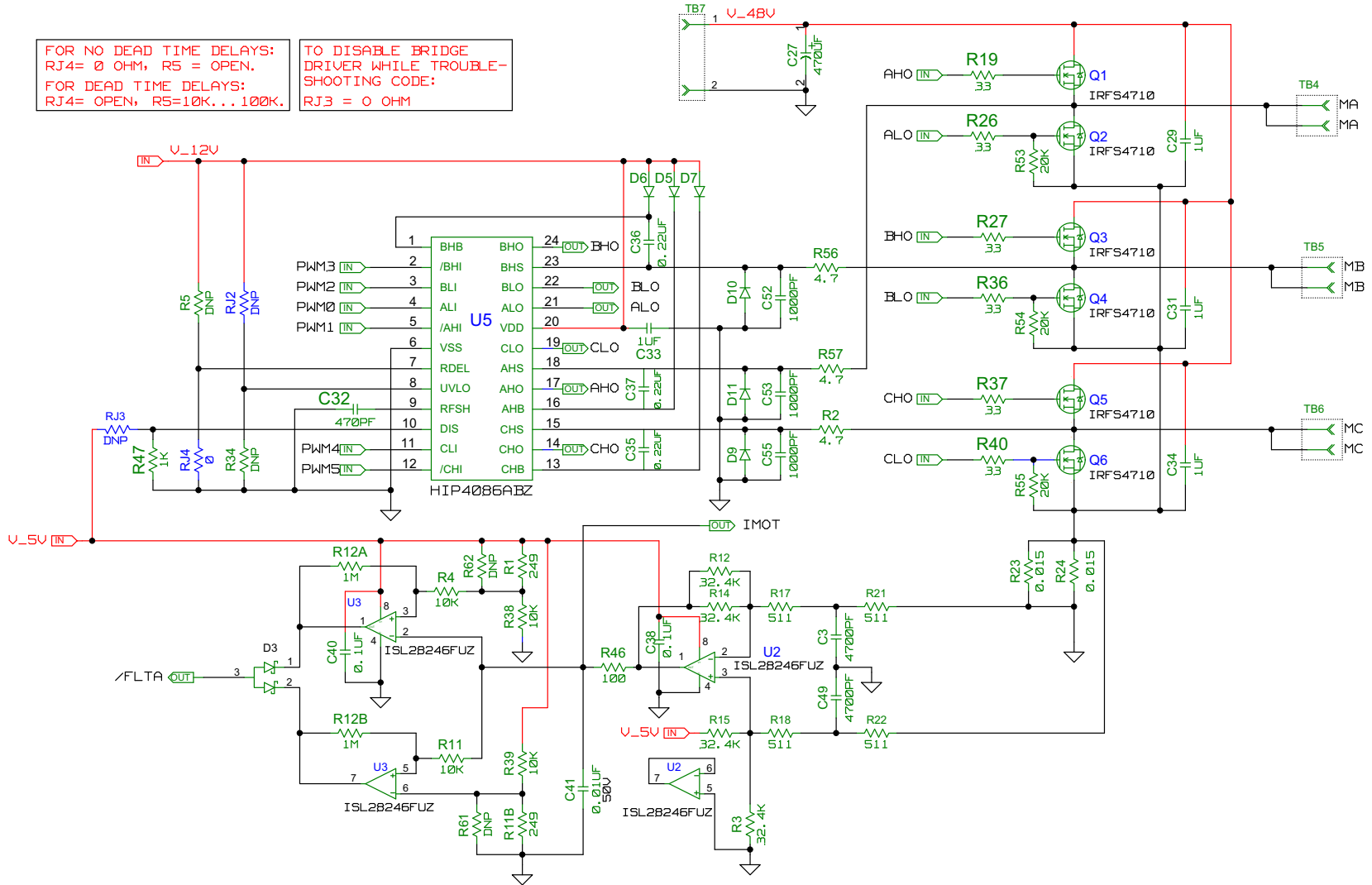

FIGURE 18. BRIDGE AND CURRENT SENSE

PCB Layout

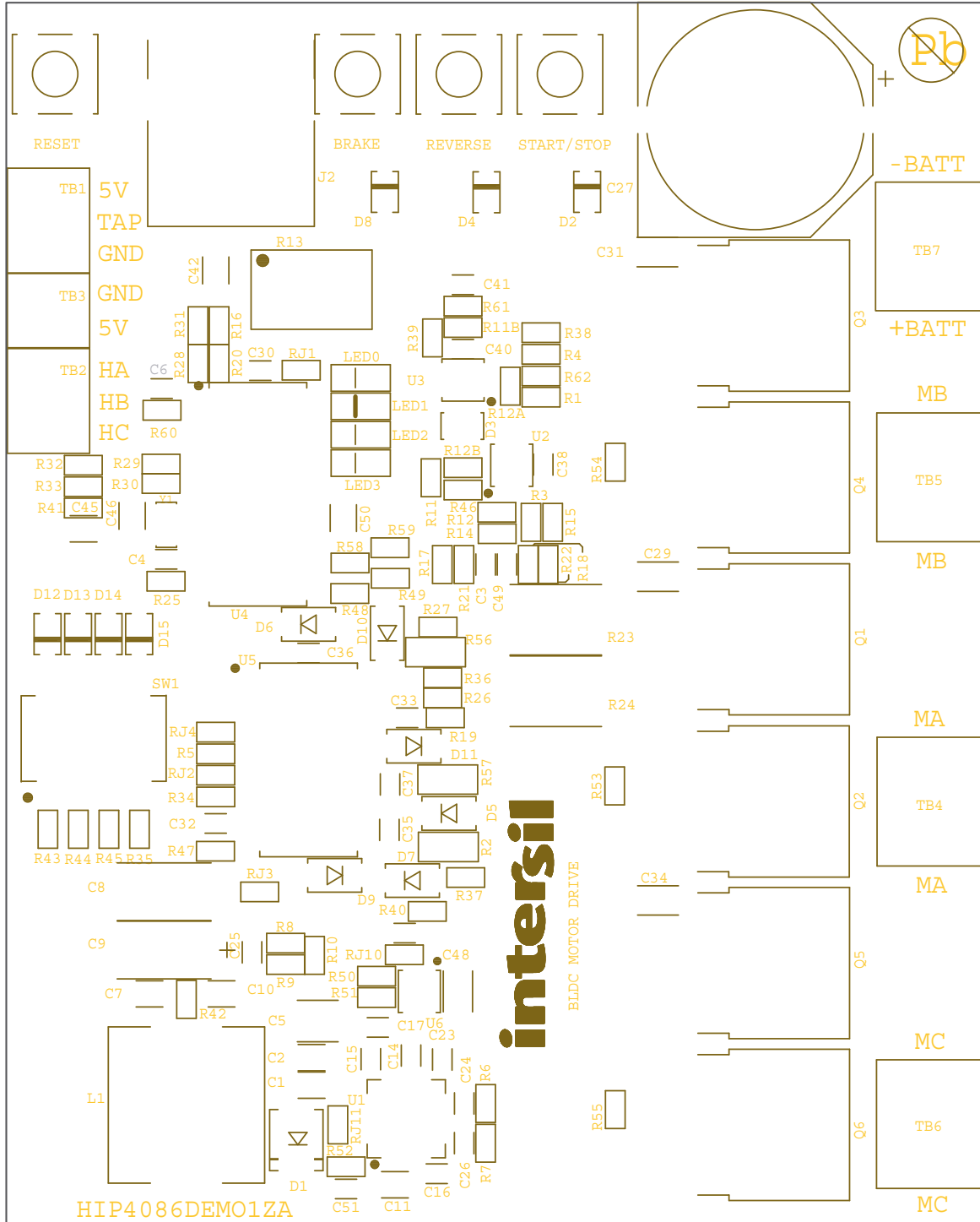

FIGURE 19. PCB SILKSCREEN, REV A

PCB Layout (Continued)

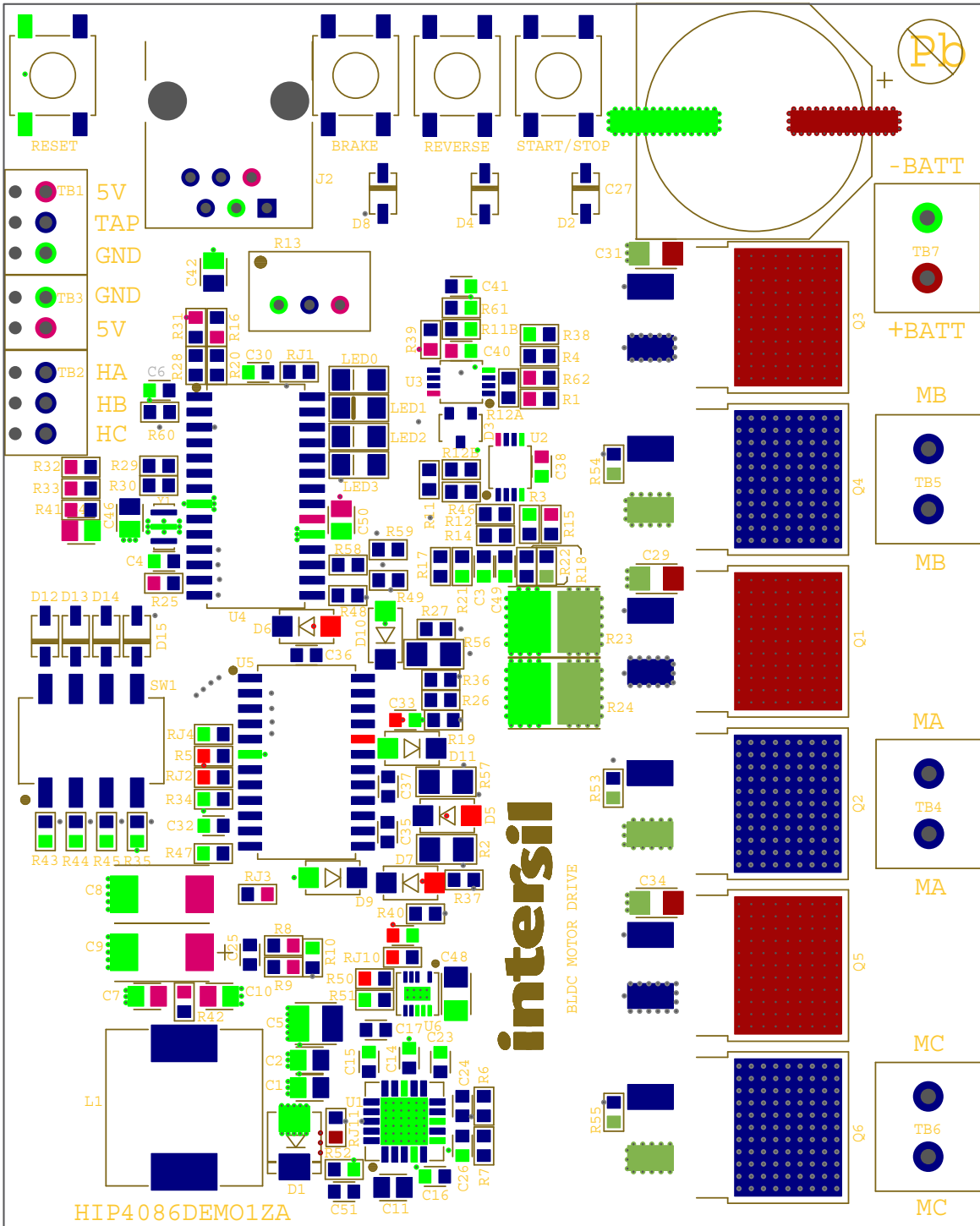

FIGURE 20. SILKSCREEN WITH PADS, REV A

PCB Layout (Continued)

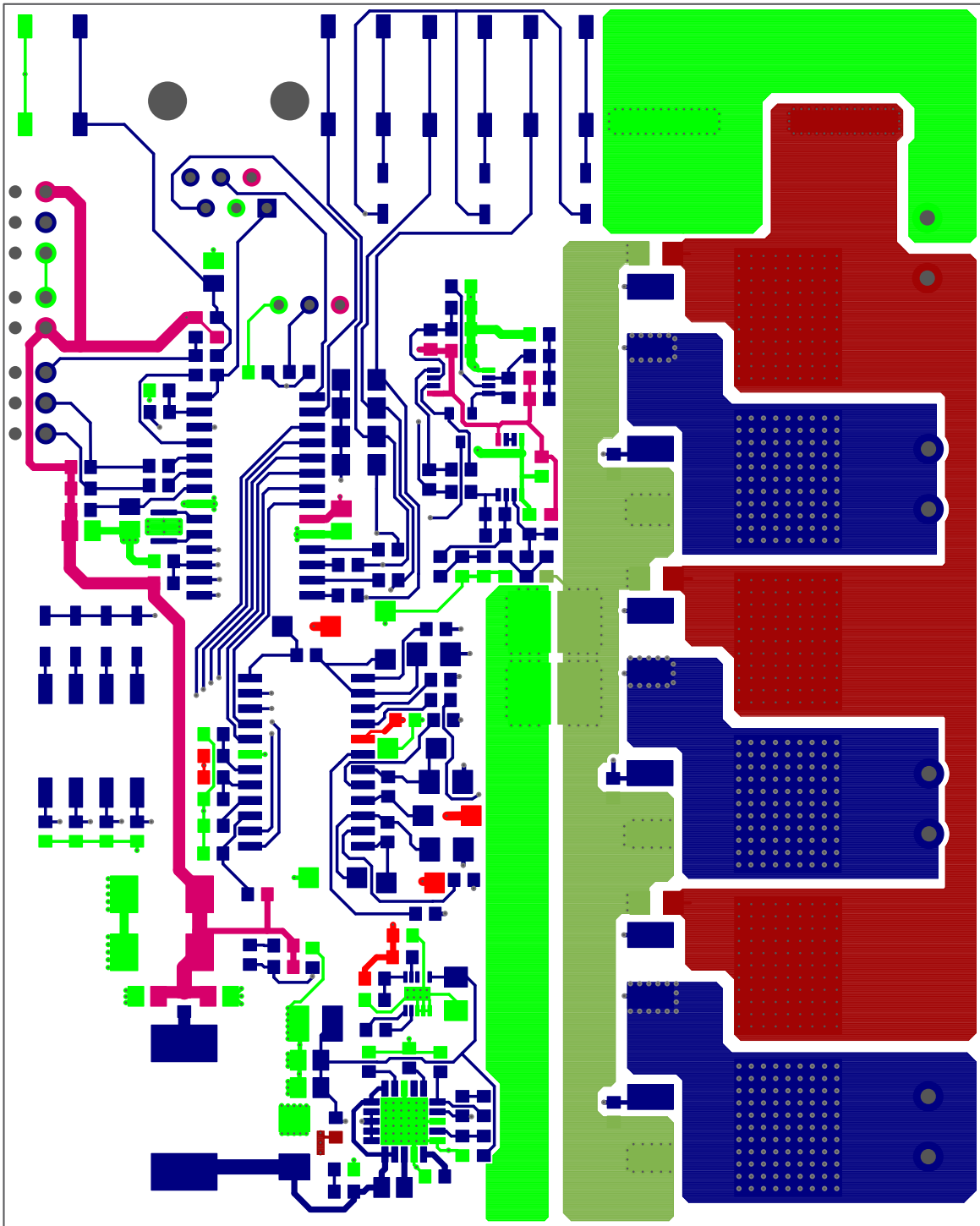

FIGURE 21. TOP LAYER, REV A

PCB Layout (Continued)

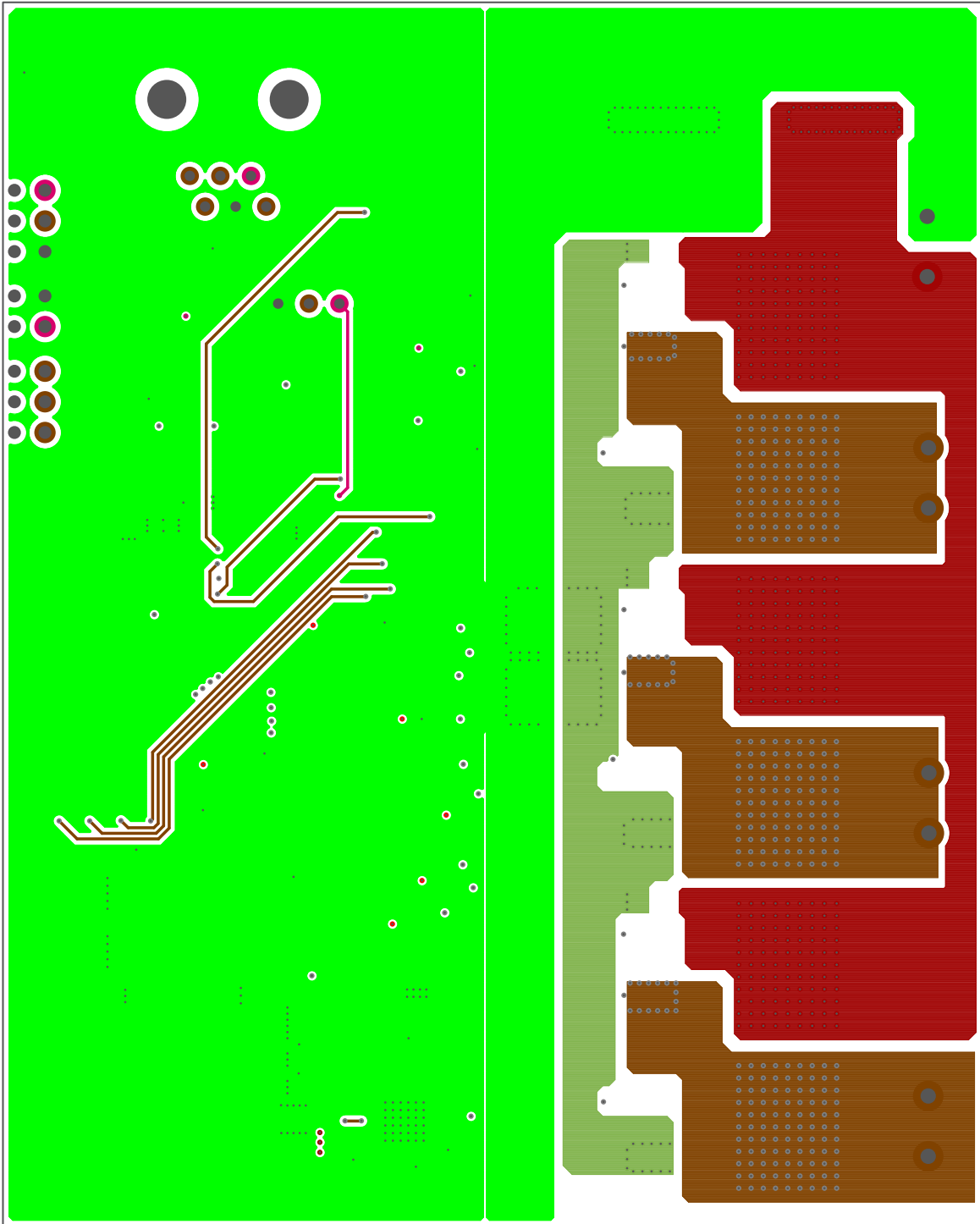

FIGURE 22. LAYER 2, REV A

PCB Layout (Continued)

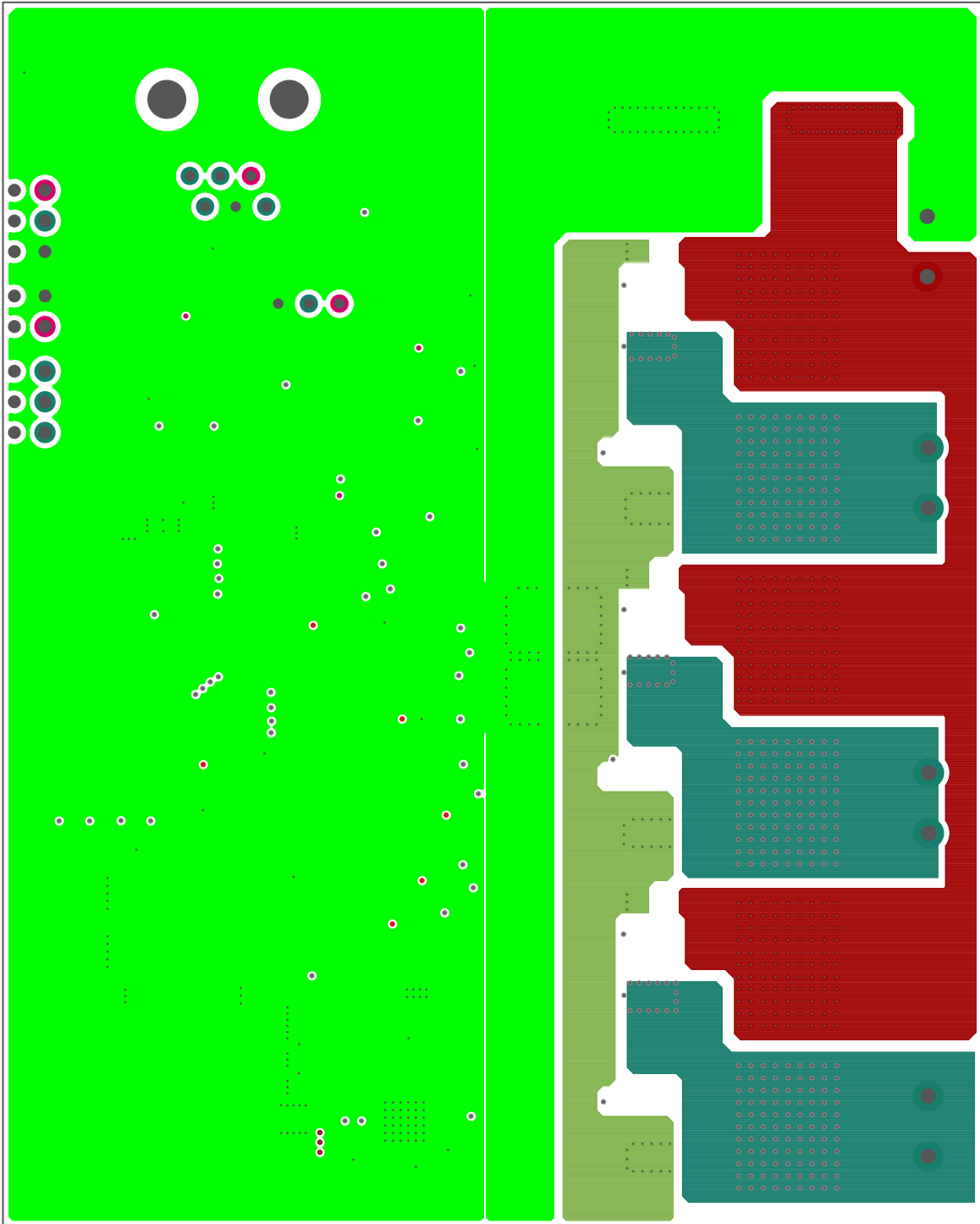

FIGURE 23. LAYER 3, REV A

PCB Layout (Continued)

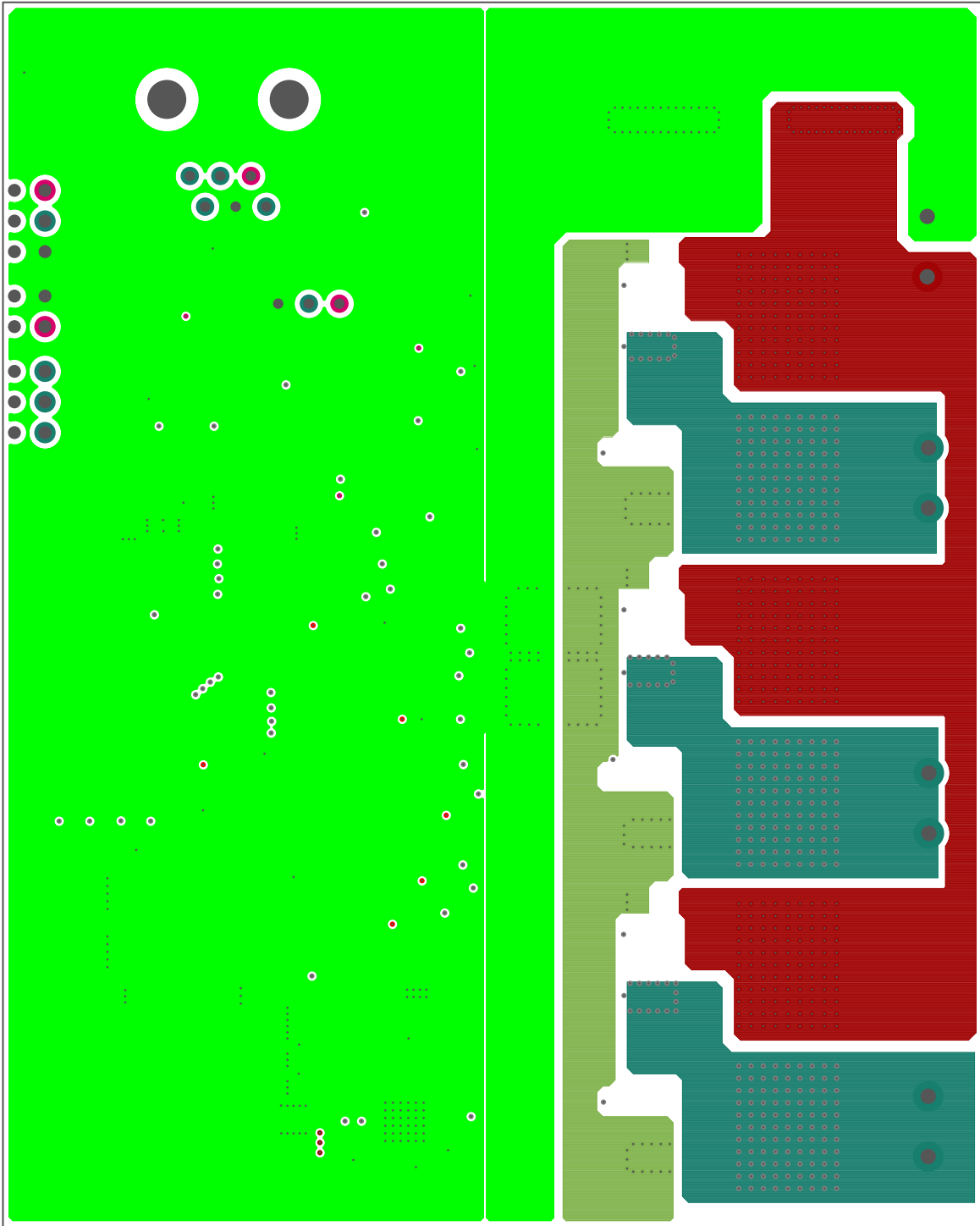

FIGURE 24. BOTTOM LAYER, REV A

## Test Mode

To validate the correct performance of the HIP4086 demo board, a built-in test procedure can be used to verify that the board is fully functional. A 50V, 200mA lab supply and an oscilloscope are necessary to perform this test. No motor is required and should **not** be connected. Each individual test section must be valid before proceeding to the next step. Stop testing at any failure.

### Test Mode Setup

1. Connect a ~75mm (3 inch) wire to the GND terminal close to the HA, HB, HC terminal block.
2. Setup a scope with the vertical scale = 20V/div and the time base = 10µs/div. Three probes are recommended but not absolutely necessary.
3. Adjust the lab supply to 50VDC and 200mA current limit.
4. With the lab supply turn off, connect to the +BATT and -BATT terminal inputs of the HIP4086DEMO1Z board.
5. Set dip switch positions 1 through 4 to on.
6. While pressing simultaneously the BRAKE and REVERSE push buttons, turn on the lab supply.
7. If led0 and led3 are flashing or if no LEDs are on, the test mode was not initiated correctly, the board is faulty or the microcontroller is not programmed. To confirm, restart the test mode setup. If one or more LEDs are on **without** flashing, the test mode is now active. At this point the binary combination of the on LEDs indicates the **version number** of the firmware (see Figure 25). Figure 26 shows other examples of faulty setup or failed test results.

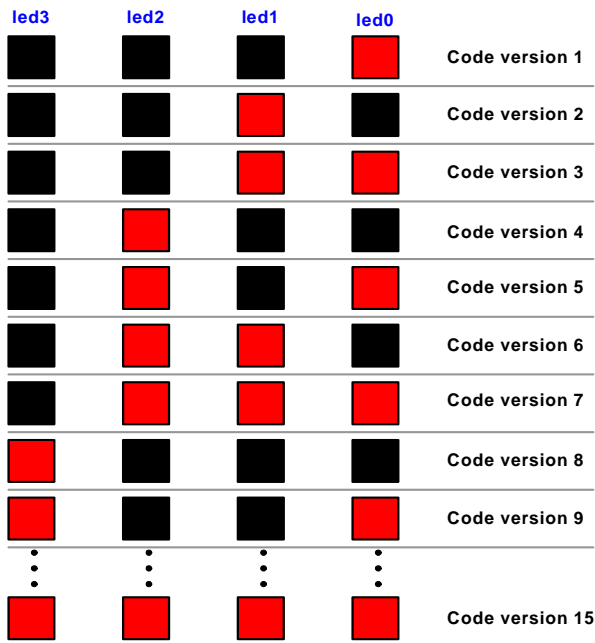

FIGURE 25. CODE VERSION NUMBERS

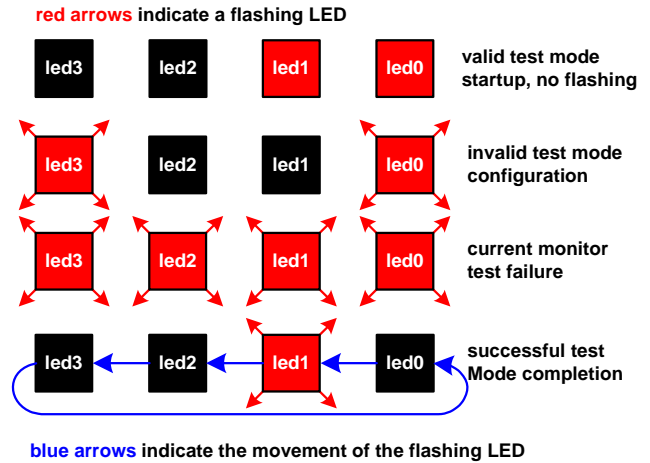

FIGURE 26. EXAMPLES OF LED TEST STATUS

### Push-button Test

1. Press the START/STOP button. All four LEDs should turn on.
2. Press again the START/STOP button. Led0 should turn off.
3. Press the REVERSE button. Led1 should turn off.
4. Press the BRAKE button. Led2 should turn off.
5. Press again the BRAKE button. Led3 should turn off. At this point all four LEDs are off and correct operation of the push buttons is confirmed.

### Hall Inputs and Bridge Tests

#### MA OUTPUT TEST

1. Using the 75mm wire, short the HA terminal input to ground. LED0 should turn on.
2. While the HA input is grounded, observe the following waveforms in Figure 27, on the MA, MB, and MC terminals.

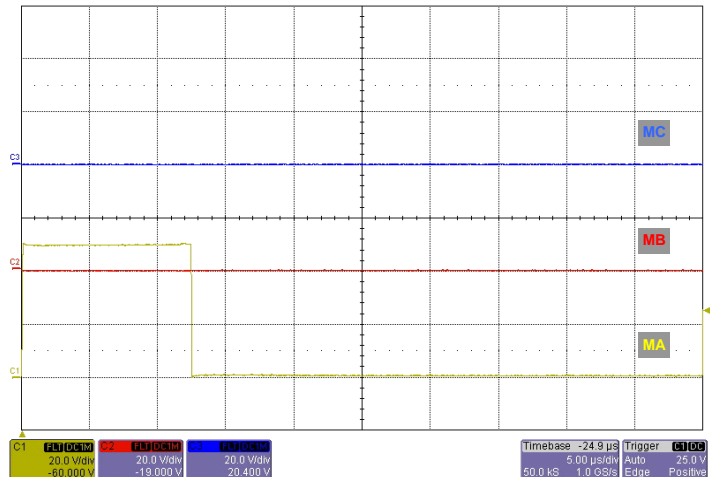

FIGURE 27. WAVEFORMS ON MA, MB, and MC WITH HA GROUNDED



# Application Note 1829

- Figure 28 illustrates incorrect waveforms. There should not be any switching on MB and MC while MA is low. (At the very edge of MA falling, there may be a small amount of induced switching noise)

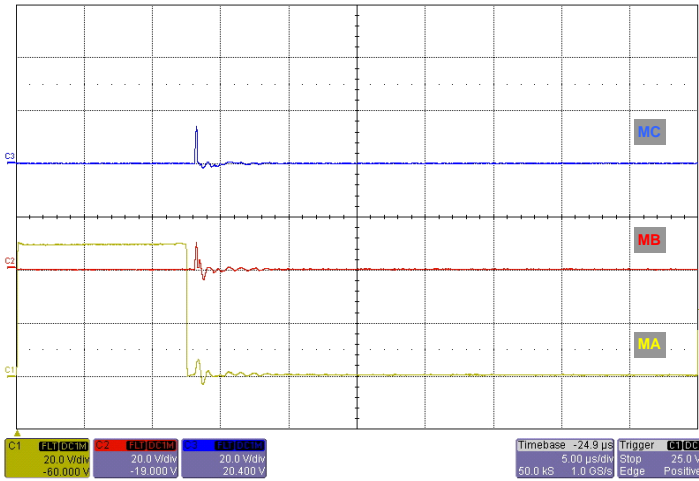

FIGURE 28. WAVEFORMS ON MA, MB, and MC WITH HA GROUNDED

- While the HA input is grounded, observe that the lab supply current is < 45mA.

## MB OUTPUT TEST

- Using the 75mm wire, short the HB terminal input to ground. Led1 should turn on.
- While the HB input is grounded, observe the following waveforms on the MA, MB, and MC terminals.

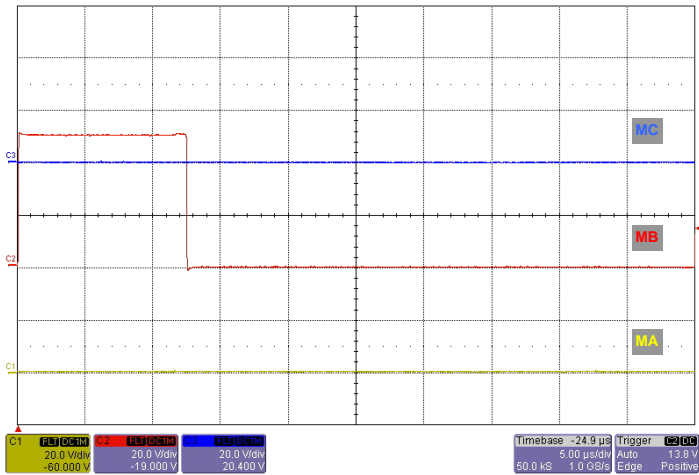

FIGURE 29. WAVEFORMS ON MA, MB, and MC WITH HB GROUNDED

As the example in Figure 27 shows, there should be no switching disturbances on MC and MA.

- While the HB input is grounded, observed that the lab supply current is < 45mA.

## MB OUTPUT TEST

- Using the 75mm wire, short the HC terminal input to ground. Led2 should turn on. After a short pause, led3 will also turn on. At this point, all four LEDs are on.
- While the HC input is grounded, observe the following waveforms on the MA, MB, and MC terminals.

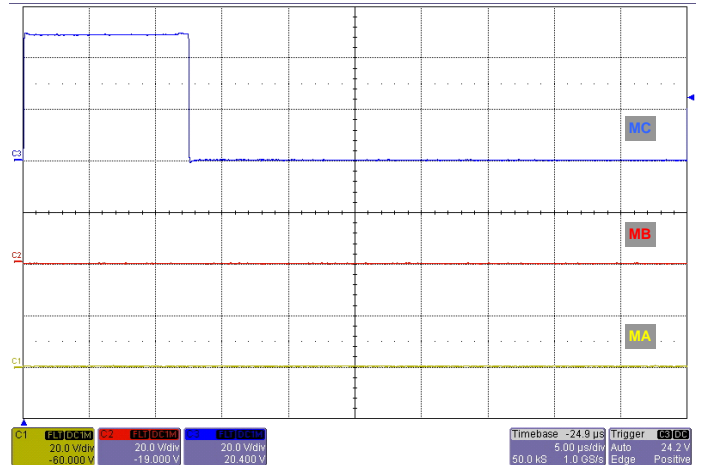

FIGURE 30. WAVEFORMS ON MA, MB, and MC WITH HC GROUNDED

As the example in Figure 27 shows, there should be no switching disturbances on MB and MA.

- While the HC input is grounded, observe that the lab supply current is < 45mA.

## Dip Switch Test

- Move each dip switch, one at a time starting with position 1, to the off position.
- Observe that led0, led1, led2, and led3 turn off one at a time in synchronous with the dip switches being turned off.

## Potentiometer Test

- After a short pause, all LEDs will turn on if the potentiometer is turned fully to the right (CW). If the LEDs are not on, rotate the potentiometer to the right until all LEDs turn or when the potentiometer starts to click. If all LEDs do not turn on, the board is faulty.
- After all the LEDs turn on, rotate the potentiometer to the left (CCW). Observe that led3, led2, led1, and led0 turn off sequentially as the potentiometer is rotated towards the minimum voltage setting.

## Current Monitor Test

- This final test is performed automatically after the potentiometer test. No inputs from the test operator is necessary. If successful, all four LEDs are sequentially flashing one at a time. If not successful, all four LEDs flash simultaneously.
- The end.

Intersil Corporation reserves the right to make changes in circuit design, software and/or specifications at any time without notice. Accordingly, the reader is cautioned to verify that the Application Note or Technical Brief is current before proceeding.

For information regarding Intersil Corporation and its products, see [www.intersil.com](http://www.intersil.com)