

### Features

- 5W Solution for Wireless Power Consortium (WPC)-compliant power transmitter design A5/A11
- Conforms to WPC specification version 1.1 specifications
- 5V±5% Operating Input Voltage
- Uses Full-Bridge (Integrated Half-Bridge Plus External-Half Bridge) Inverter.
- Closed-Loop Power Transfer Control between Base Station and Mobile Device
- Demodulates and Decodes WPC-Compliant Message Packets
- Integrated RESET Function
- Proprietary Back-Channel Communication
- I<sup>2</sup>C Interface
- Open-Drain LED Indicator Outputs
- Over-Temperature/Current Protection
- Security and encryption up to 64 bits
- Foreign Object Detection (FOD)

### Applications

- WPC-Compliant Wireless Charging Base Stations

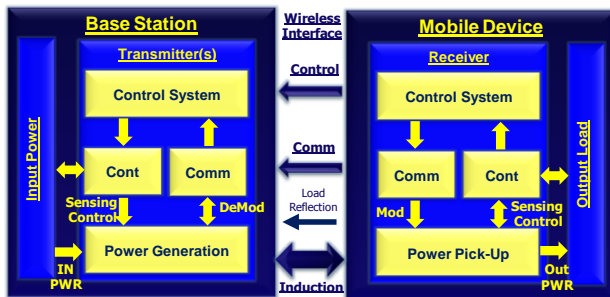

Package: 6x6-48 TQFN (See page 26)  
Ordering Information (See page 27)

### Description

The IDTP9035 is a highly-integrated WPC-compliant wireless power transmitter IC for power transmitter design A5 and A11. The device operates with a 5V (±5%) adaptor, and utilizes an external half-bridge in addition to its integrated half-bridge inverter to provide a highly-integrated two-chip solution for A5/A11 transmitter applications. It controls the transferred power by modulating the switching frequency of the full-bridge inverter from 110kHz to 205kHz at a fixed 50% duty cycle specified by the WPC specification for an A5/A11 transmitter. It contains logic circuits required to demodulate and decode WPC-compliant message packets sent by the mobile device to adjust the transferred power.

The IDTP9035 is an intelligent device that periodically pings the area surrounding the base station to detect a mobile device for charging while minimizing idle power. Once the mobile device is detected and authenticated, the IDTP9035 continuously monitors all communications from the mobile device, and adjusts the transmitted power accordingly by varying the switching frequency of the half-bridge inverter.

The IDTP9035 features a proprietary back-channel communication mode which enables the device to communicate with IDT's wireless power receiver solutions (e.g. IDTP9020). This feature enables additional layers of capabilities relative to standard WPC requirements.

This device also features optional security and encryptions to securely authenticate the receiver before transferring power. This feature is available when an IDTP9020 is used for the receiver.

The device includes over-temperature/current protection and a Foreign Object Detection (FOD) method to protect the base station and mobile device from overheating in the presence of a metallic foreign object. It manages fault conditions associated with power transfer and controls status LEDs to indicate operating modes.

### Typical Application Circuit

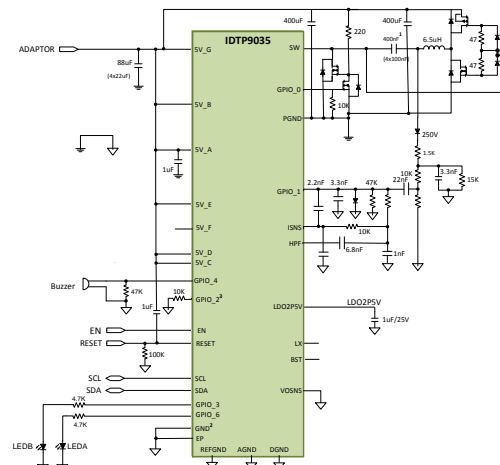

# TYPICAL APPLICATION CIRCUIT

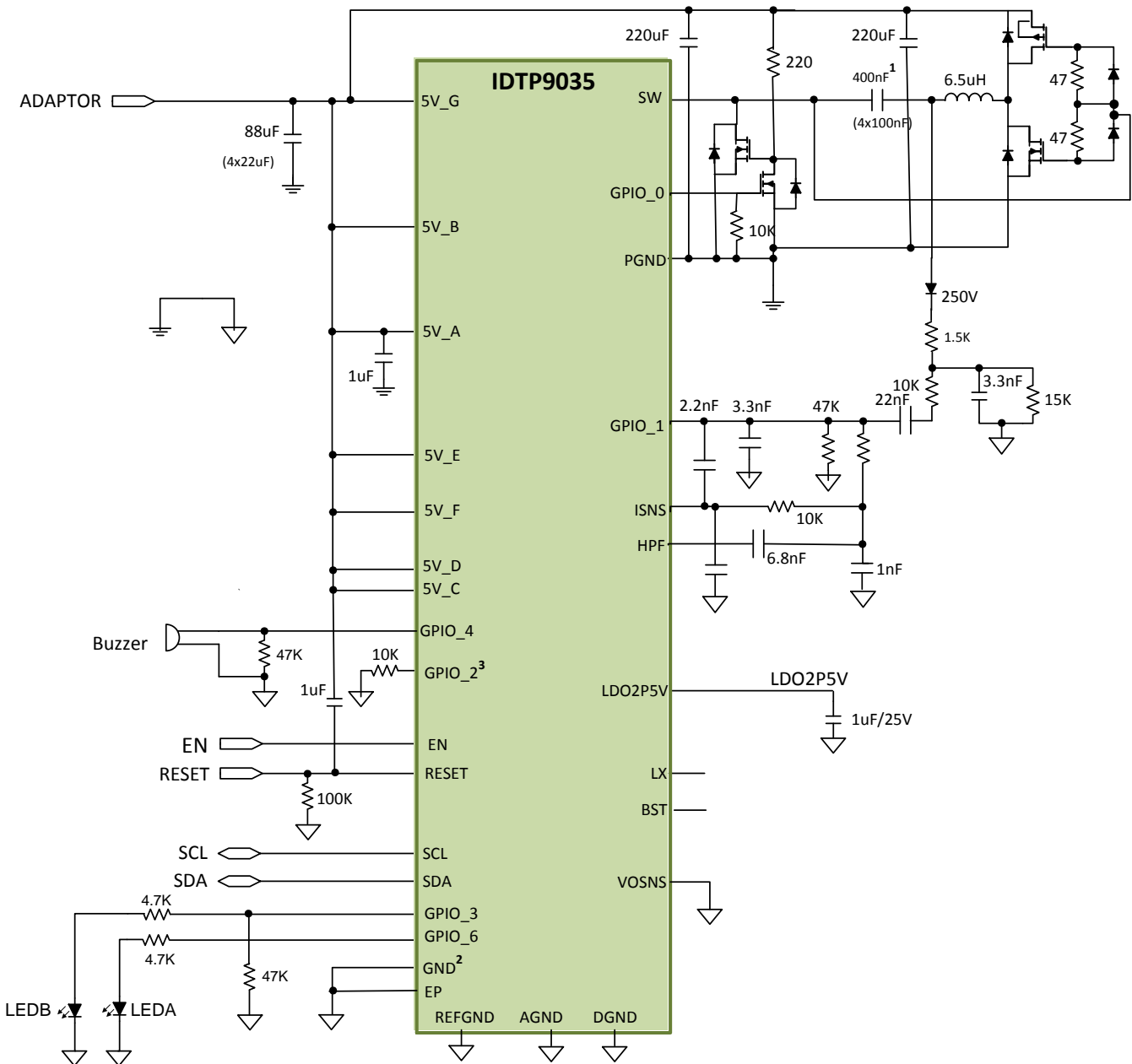

Figure 1. IDTP9035 Simplified Application Schematic

Note 1: NPO/COG-type ceramic capacitor.

Note 2: For PCB layout, use single-point reference ("star" ground), refer to design schematic in Figure 9).

Note 3: The 220uF bulk capacitors are necessary for proper operation of the transmitter.

## ABSOLUTE MAXIMUM RATINGS

These absolute maximum ratings are stress ratings only. Stresses greater than those listed below (Table 1 and Table 2) may cause permanent damage to the device. Functional operation of the IDTP9035 at absolute maximum ratings is not implied. Exposure to absolute maximum rating conditions for extended periods may affect long-term reliability.

**Table 1. Absolute Maximum Ratings Summary. All voltages are referred to ground, unless otherwise noted.**

PINS	MAXIMUM RATING	UNITS
5V_A, 5V_B, 5V_C, 5V_D, 5V_E, 5V_F, 5V_G. <b>THESE PINS MUST BE CONNECTED TOGETHER AT ALL TIMES.</b>	-0.3 to 6.0	V
$\overline{EN}$ , IC_1, IC_2, SW <sup>5</sup> , GPIO_0, GPIO_1, GPIO_2, GPIO_3, GPIO_4, GPIO_5, GPIO_6, HPF, ISNS, RESET, SCL, SDA, VOSNS	-0.3 to VIN+0.3	V
LDO2P5V, XIN, XOUT	-0.3 to 2.75	V
AGND, DGND, PGND, REFGND	-0.3 to +0.3	V

**Table 2. Package Thermal Information**

SYMBOL	DESCRIPTION	MAXIMUM RATING	UNITS
$\theta_{JA}$	Thermal Resistance Junction to Ambient (NTG48 - TQFN)	30.8	°C/W
$\theta_{JC}$	Thermal Resistance Junction to Case (NTG48 - TQFN)	14.6	°C/W
$\theta_{JB}$	Thermal Resistance Junction to Board (NTG48 - TQFN)	0.75	°C/W
T <sub>J</sub>	Junction Temperature	-40 to +150	°C
T <sub>A</sub>	Ambient Operating Temperature	-40 to +85	°C
T <sub>STG</sub>	Storage Temperature	-55 to +150	°C
T <sub>LEAD</sub>	Lead Temperature (soldering, 10s)	+300	°C

**Note 1:** The maximum power dissipation is  $P_{D(MAX)} = (T_{J(MAX)} - T_A) / \theta_{JA}$  where  $T_{J(MAX)}$  is 125°C. Exceeding the maximum allowable power dissipation will result in excessive die temperature, and the device will enter thermal shutdown.

**Note 2:** This thermal rating was calculated on JEDEC 51 standard 4-layer board with dimensions 3" x 4.5" in still air conditions.

**Note 3:** Actual thermal resistance is affected by PCB size, solder joint quality, layer count, copper thickness, air flow, altitude, and other unlisted variables.

**Note 4:** For the NTG48 package, connecting the 4.1 mm X 4.1 mm EP to internal/external ground planes with a 5x5 matrix of PCB plated-through-hole (PTH) vias, from top to bottom sides of the PCB, is recommended for improving the overall thermal performance.

Table 3. ESD Information

TEST MODEL	PINS	MAXIMUM RATINGS	UNITS
HBM	All pins.	$\pm 2000$	V
CDM	All pins.	$\pm 500$	V

# ELECTRICAL CHARACTERISTICS

$\overline{EN}$  = RESET = 0V, 5V\_A = 5V\_B = 5V\_C = 5V\_D = 5V\_E = 5V\_F = 5V\_G = 5V. T<sub>A</sub> = -40 to +85°C, unless otherwise noted. Typical values are at 25°C, unless otherwise noted.

**Table 4. Device Characteristics**

SYMBOL		DESCRIPTION	CONDITIONS	MIN	TYP	MAX	UNITS
<b>Half-Bridge Inverter</b>							
V <sub>IN</sub>		Input Supply Operating Voltage Range <sup>1</sup>		4.75		5.25	V
I <sub>IN</sub> <sup>2</sup>	I <sub>IN_A</sub>	Standby Input Current	After power-up sequence complete, average including pinging.		20		mA
F <sub>SW_LOW</sub>	Switching Frequency at SW	WPC Operating Range, in compliance with WPC requirements		110			kHz
F <sub>SW_HIGH</sub>					205	kHz	
R <sub>DS(ON)_HS</sub>			Between IN and SW		175		mΩ
R <sub>DS(ON)_LS</sub>			Between SW and PGND		130		mΩ
<b>Inverter OCP</b>							
I <sub>IN_OCP</sub>		Over-Current Protection Trip Point	V <sub>IN</sub> = 5V, cycle-by-cycle protection.	4	5.5	7	A
<b>Low Drop Out Regulator (For Biasing Internal Circuitry Only)<sup>3</sup></b>							
<b>LDO2P5V<sup>3</sup></b>							
V <sub>LDO2P5V_IN</sub>		Input Voltage Range	Supplied from BUCK5VT		5		V
V <sub>LDO2P5V</sub>		Output Voltage	I <sub>Load</sub> = 2mA		2.5		V
I <sub>OUT</sub>		External Load				5	mA
<b>Thermal Shutdown Thermal Shutdown</b>							
T <sub>SD</sub>	Thermal Shutdown	Temperature Rising Threshold			140		°C
		Temperature Falling Threshold			110		
<b><math>\overline{EN}</math></b>							
V <sub>IH</sub>					900		mV
V <sub>IL</sub>					550		mV
I <sub>EN</sub>		$\overline{EN}$ input current	V <sub>EN</sub> = 5V		7.5		μA
<b>General Purpose Inputs / Outputs (GPIO)</b>							
V <sub>IH</sub>		Input Threshold High		3.5			V
V <sub>IL</sub>		Input Threshold Low				1.5	V
I <sub>LKG</sub>		Input Leakage		-1		+1	μA
V <sub>OH</sub>		Output Logic High	I <sub>OH</sub> =-8mA	4			V
V <sub>OL</sub>		Output Logic Low	I <sub>OL</sub> =8mA			0.5	V

## ELECTRICAL CHARACTERISTICS

$\overline{EN} = \text{RESET} = 0\text{V}$ ,  $5\text{V}_A = 5\text{V}_B = 5\text{V}_C = 5\text{V}_D = 5\text{V}_E = 5\text{V}_F = 5\text{V}_G = 5\text{V}$ .  $T_A = -40$  to  $+85^\circ\text{C}$ , unless otherwise noted. Typical values are at  $25^\circ\text{C}$ , unless otherwise noted.

Table 5. Device Characteristics, Continued

SYMBOL	DESCRIPTION	CONDITIONS	MIN	TYP	MAX	UNITS
<b>RESET</b>						
$V_{IH}$	Input Threshold High		3.5			V
$V_{IL}$	Input Threshold Low				1.5	V
$I_{LKG}$	Input Leakage		-1		+1	$\mu\text{A}$
<b>SCL, SDA (I<sup>2</sup>C Interface)</b>						
$f_{SCL}$	Clock Frequency	EEPROM loading, Step 1, IDTP9035 as Master		100		kHz
$f_{SCL}$	Clock Frequency	EEPROM loading, Step 2, IDTP9035 as Master		300		kHz
$f_{SCL}$	Clock Frequency	IDTP9035 as Slave	0		400	kHz
$t_{HD,STA}$	Hold Time (Repeated) for START Condition		0.6			$\mu\text{s}$
$t_{HD,DAT}$	Data Hold Time	I <sup>2</sup> C-bus devices	10			ns
$t_{LOW}$	Clock Low Period		1.3			$\mu\text{s}$
$t_{HIGH}$	Clock High Period		0.6			$\mu\text{s}$
$t_{SU,STA}$	Set-up Time for Repeated START Condition		100			ns
$T_{BUF}$	Bus Free Time Between STOP and START Condition		1.3			$\mu\text{s}$
$C_B$	Capacitive Load for Each Bus Line				100	pF
$C_{BIN}$	SCL, SDA Input Capacitance			5		pF
$V_{IL}$	Input Threshold Low	When powered by device 5V			1.5	V
$V_{IH}$	Input Threshold High		3.5			V
$I_{LKG}$	Leakage Current		-1.0		1.0	$\mu\text{A}$
$V_{OL}$	Output Logic Low (SDA)	$I_{PD} = 2\text{mA}$ (Note 1)			0.5	V

## ELECTRICAL CHARACTERISTICS

$\overline{EN}$  = RESET = 0V, 5V\_A = 5V\_B = 5V\_C = 5V\_D = 5V\_E = 5V\_F = 5V\_G = 5V. T<sub>A</sub> = -40 to +85°C, unless otherwise noted. Typical values are at 25°C, unless otherwise noted.

Table 6. Device Characteristics, Continued

SYMBOL	DESCRIPTION	CONDITIONS	MIN	TYP	MAX	UNITS
<b>Analog-to-Digital Converter</b>						
N	ADC Conversion Resolution			12		Bit
f <sub>SAMPLE</sub>	Sampling Rate			62.5		KSPS
Channel	Number of Channels at ADC MUX input			8		
ADC <sub>CLK</sub>	ADC Clock Frequency			1		MHz
V <sub>IN_FS</sub>	Full-Scale Input Voltage			2.5		V
<b>Microcontroller</b>						
F <sub>CLOCK</sub>	Clock Frequency			40		MHz
V <sub>MCU</sub>	MCU Supply Voltage from internal 2.5V LDO			2.5		V

**Note 1** 5V\_A = 5V\_B = 5V\_C = 5V\_D = 5V\_E = 5V\_F = 5V\_G. These pins must be connected together at all times.

**Note 2:** This current is the sum of the input currents for 5V\_A = 5V\_B = 5V\_C = 5V\_D = 5V\_E = 5V\_F = 5V\_G.

**Note 3:** LDO2P5V is intended only as an internal device supply and must not be loaded.

# BLOCK DIAGRAM

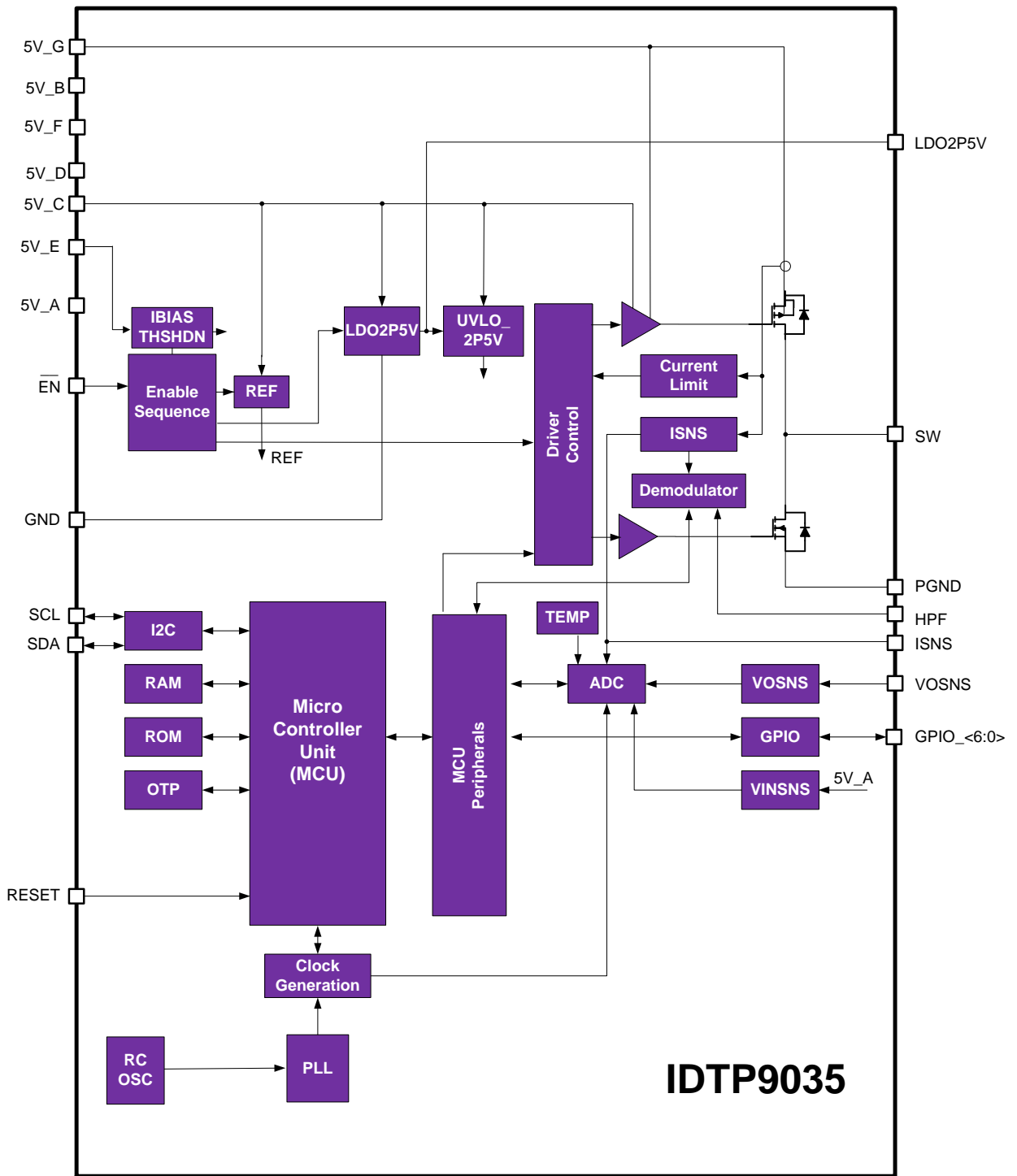

Figure 2. IDTP9035 Internal Functional Block Diagram



# PIN CONFIGURATION

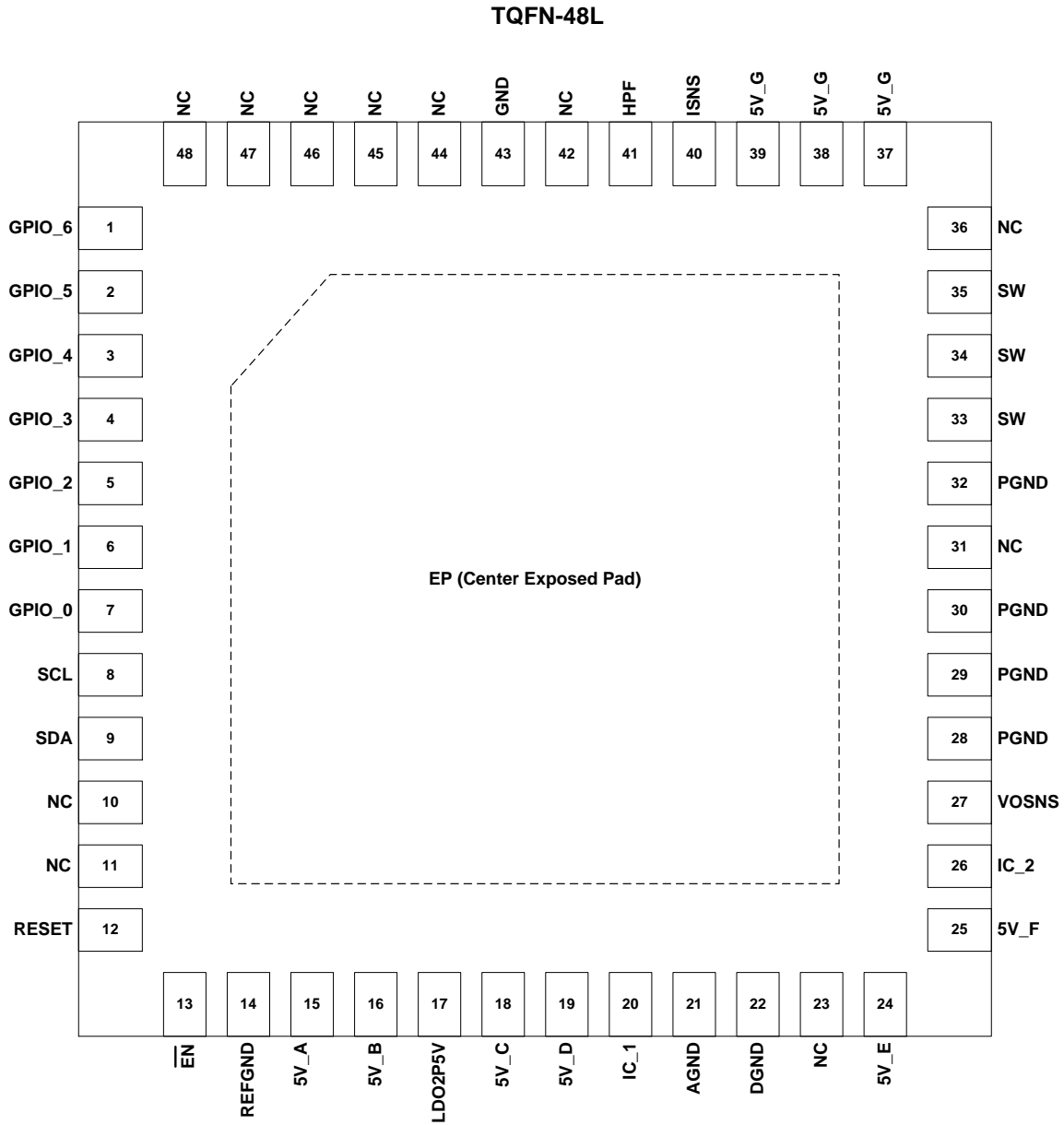

Figure 3. IDTP9035 Pin Configuration (NTG48 TQFN-48L 6.0 mm x 6.0 mm x 0.75 mm, 0.4mm pitch)

## PIN DESCRIPTION

Table 7. IDTP9035 NTG48 Package Pin Functions by Pin Number ( )

PIN	NAME	TYPE	DESCRIPTION
1	GPIO_6	I/O	General purpose input/output 6
2	GPIO_5	I/O	General purpose input/output 5
3	GPIO_4	I/O	General purpose input/output 4
4	GPIO_3	I/O	General purpose input/output 3
5	GPIO_2	I/O	General purpose input/output 2
6	GPIO_1	I/O	General purpose input/output 1
7	GPIO_0	I/O	General purpose input/output 0
8	SCL	I/O	I <sup>2</sup> C clock
9	SDA	I/O	I <sup>2</sup> C data
10	NC	NC	Must be connected to GND.
11	NC	NC	Must be left unconnected.
12	RESET	I	Active-high chip reset pin. A 1μF ceramic capacitor must be connected between this pin and LDO5V, and a 100kΩ resistor to GND.
13	$\overline{EN}$	I	Active-low enable pin. Device is suspended and placed in low current (sleep) mode when pulled high. Tie to GND for stand-alone operation.
14	REFGND	-	Signal ground connection. Must be connected to AGND.
15	5V_A <sup>1</sup>	I	A 0.1μF ceramic capacitor must be connected between this pin and GND. This pin must be connected to pins 16, 18, 19, 24, 25, 37, 38, and 39.
16	5V_B <sup>1</sup>	I	A 1μF ceramic capacitor must be connected between this pin and GND. This pin must be connected to pins 15, 18, 19, 24, 25, 37, 38, and 39.
17	LDO2P5V <sup>2</sup>	O	2.5V LDO output. A 1μF ceramic capacitor must be connected between this pin and GND.
18	5V_C <sup>1</sup>	I	2.5V LDO input. A 10μF and a 0.1μF ceramic capacitor must be connected between this pin and GND. This pin must be connected to pins 15, 16, 19, 24, 25, 37, 38, and 39.
19	5V_D <sup>1</sup>	I	Power and digital supply input to internal circuitry. This pin must be connected to pins 15, 16, 18, 24, 25, 37, 38, and 39.

**Table 7. IDTP9035 NTG48 Package Pin Functions by Pin Number ()**

PIN	NAME	TYPE	DESCRIPTION
20	IC_1	NC	Internal connection, do not connect.
21	AGND	-	Analog ground connection. Connect to signal ground. Must be connected to REFGND.
22	DGND	-	Digital ground connection. Must be connected to GND.
23	NC	NC	Not internally connected.
24	5V_E <sup>1</sup>	I	Power supply input. Connect 0.1 $\mu$ F and 1 $\mu$ F ceramic capacitors between this pin and PGND. This pin must be connected to pins 15, 16, 18, 19, 25, 37, 38, and 39.
25	5V_F <sup>1</sup>	I	This pin must be connected to pins 15, 16, 18, 19, 24, 37, 38, and 39.
26	IC_2	NC	Internal connection, do not connect.
27	VOSNS	I	Must be connected to GND.
28	PGND	-	Power ground.
29	PGND	-	Power ground.
30	PGND	-	Power ground.
31	NC	NC	Not internally connected.
32	PGND	-	Power ground.
33	SW	O	Pins 33, 34, and 35 must be connected together. Inverter switch node. Must be connected to capacitor in series with TX-A5 or A11 coil.
34	SW	O	
35	SW	O	
36	NC	NC	Not internally connected.
37	5V_G <sup>1</sup>	I	Inverter power supply input. Connect at least four 22 $\mu$ F x 25V ceramic capacitors, two 220 $\mu$ F x 6.3V low-ESR electrolytic chip capacitors, and a 0.1 $\mu$ F capacitor between this pin and ground, as close to the pin as possible. Connect all three pins, in parallel, to pins 15, 16, 18, 19, 24, 25.
38	5V_G <sup>1</sup>	I	
39	5V_G <sup>1</sup>	I	
40	ISNS	O	ISNS output signal

**Table 7. IDTP9035 NTG48 Package Pin Functions by Pin Number ( )**

PIN	NAME	TYPE	DESCRIPTION
41	HPF	I	High pass filter input
42	NC	NC	Internal connection, must be connected to GND.
43	GND	-	Ground
44	NC	NC	Internal connection, must be connected to GND.
45	NC	NC	Internal connection, must be connected to GPIO6.
46	NC	NC	Internal connection, must be connected to GPIO5.
47	NC	NC	Internal connection, must be connected to GPIO2.
48	NC	NC	Internal connection, do not connect.
EP	Center Exposed Pad	Thermal	EP is on the bottom of the package and must be electrically tied to GND. For thermal performance, solder to a large copper pad embedded with a pattern of plated through-hole vias. The die is not electrically bonded to the EP, and the EP must not be used as current-carrying electrical connection.

**Note 1:** 5V\_A, 5V\_B, 5V\_C, 5V\_D, 5V\_E, 5V\_F, 5V-G . These pins must be connected together at all times.

**Note 2:** LDO2P5V is intended only as an internal device supply and must not be loaded.

# TYPICAL PERFORMANCE CHARACTERISTICS

$\overline{EN} = 0$ ,  $5V\_A = 5V\_B = 5V\_C = 5V\_D = 5V\_E = 5V\_F = 5V\_G = 5V$ ,  $TA = 25^\circ C$ . Unless otherwise noted.

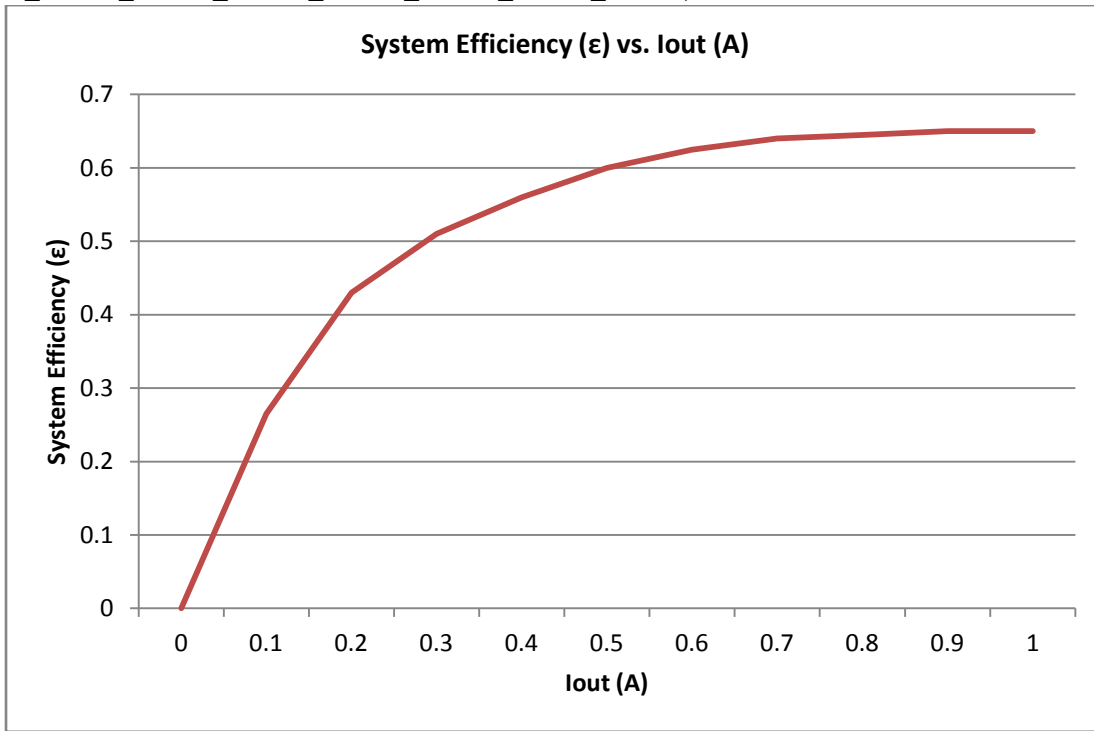

Figure 4. Efficiency vs. RX Output Power with IDTP9020 Receiver

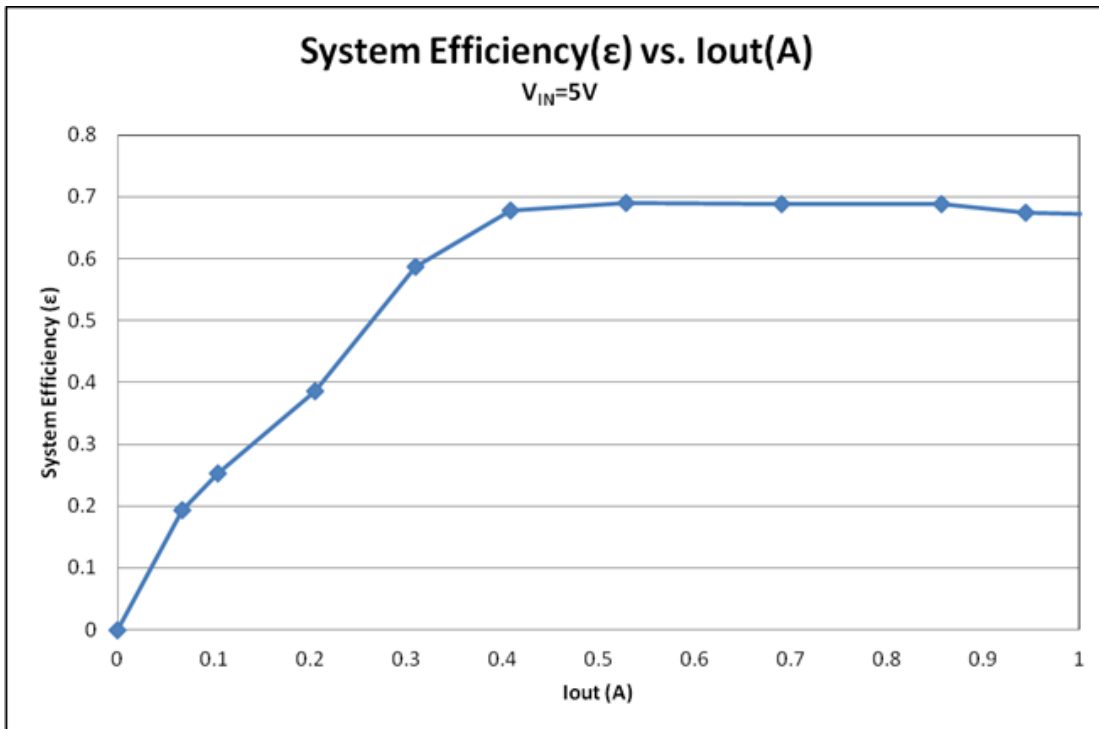

Figure 5. Spacing between TX and RX coils is 2 mm

## SYSTEMS APPLICATIONS DIAGRAM

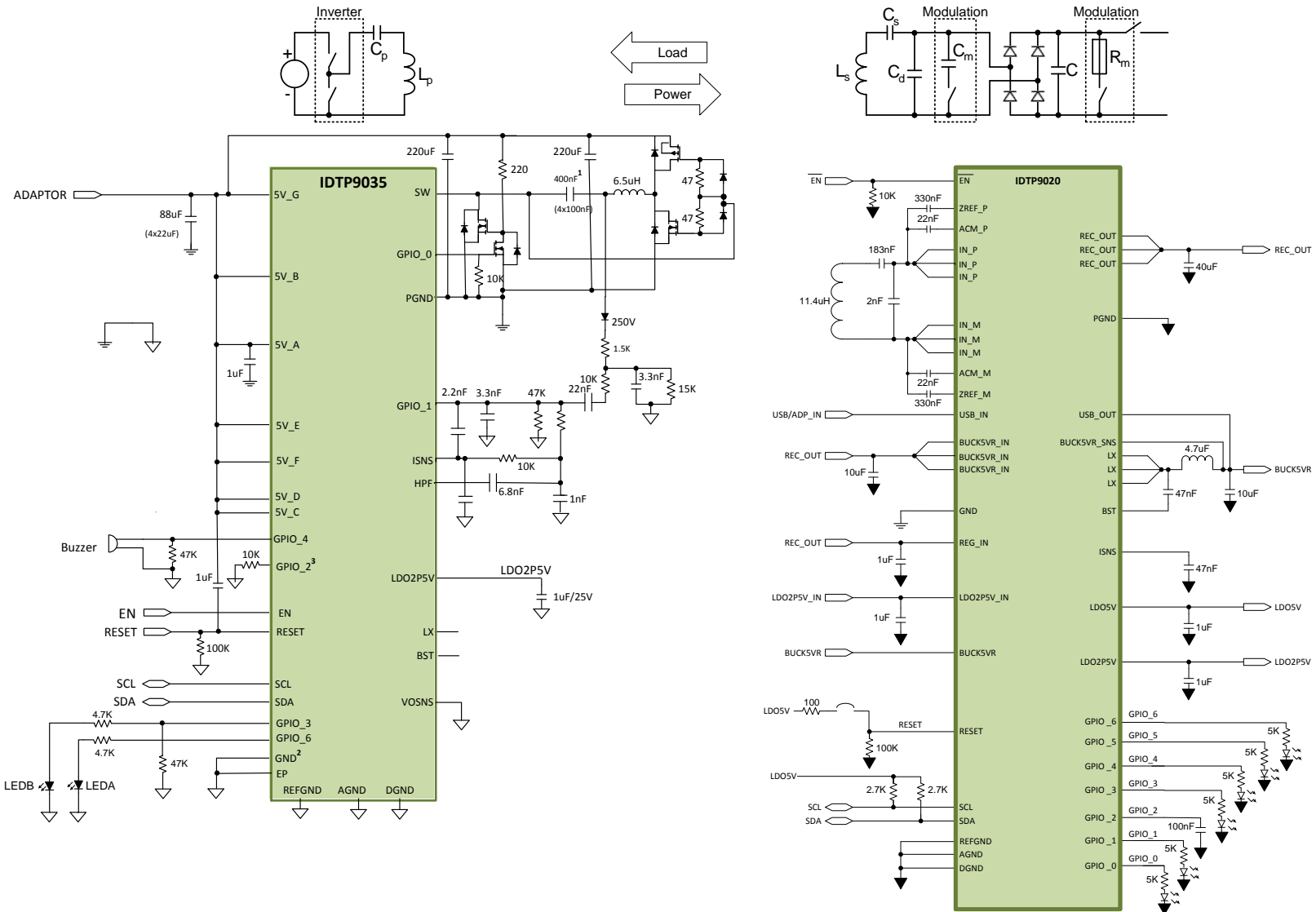

Figure 6. IDTP9035/IDTP9020 Simplified Systems Application Diagram

## THEORY OF OPERATION

The IDTP9035 is a highly-integrated WPC<sup>1</sup> (Wireless Power Consortium)-compliant wireless power charging IC solution for the transmitter base station. It can deliver more than 5W of power to the receiver when used with the IDTP9020 or 5W in WPC “Qi” mode using near-field magnetic induction as a means to transfer energy. It is the industry’s first 5V single-chip WPC-compliant solution designed to drive a WPC-compliant Type-A5/A11 transmitter coil.

### OVERVIEW

Figure 2 shows the block diagram of the IDTP9035. When 5V is applied at the 5V\_A-G pins with EN at a logic LOW, the Enable Sequence circuitry activates the voltage reference, the 2.5V LDO, and the Driver Control for the output inverter.

The voltage at the output of the LDO is monitored to ensure that it remains in regulation, and the adaptor voltage, coil current, and internal temperature are monitored for proper operation.

The Driver Control block converts a PWM signal (generated by the digital block and MCU) to the gate drive signals required by the output inverter to drive the external field-generating coil.

Communication packets from the receiver in the mobile device are recovered by the Demodulator and converted to digital signals that can be read by the MCU.

Several internal voltages are converted to their digital representations by the ADC and supplied to the MCU. Three GPIO ports are available to the system designer for driving LEDs and a buzzer. The clock for the MCU and other circuitry is generated an internal RC oscillator. I<sup>2</sup>C SDA and SCL pins permit communication with an external device or host.

### OVER-CURRENT/TEMPERATURE PROTECTION

The current in the inverter is monitored by an analog Current Limit block. If the instantaneous coil current exceeds the OCP level, the upper switch in the inverter will be turned off and the lower switch will be turned on for the remainder of the cycle. The internal temperature is also monitored, and the part is temporarily deactivated if the temperature exceeds 140°C and reactivated when the temperature falls below 110°C.

### DRIVER CONTROL BLOCK and INVERTER

The Driver Control block contains the logic, shoot-through protection, and gate drivers for the on-chip power FETs and external FETs. The on-chip and external FETs are configured as a full-bridge power inverter, effectively doubling the peak-to-peak voltage applied to the coil. The frequency of the full-bridge output waveform is set by the MCU. (For details, please refer to the simplified application diagram (Figure 1) and the reference design schematic (Figure 9)).

### DEMODULATOR

Power is transferred from the transmitter to the receiver through the coupling of their respective coils: a loosely-coupled transformer. The amount of power transferred is determined by the transmitter’s switching frequency (110kHz-205kHz, by WPC<sup>1</sup>), and is controlled by the receiver through instructions it sends back through the coils to the transmitter to change its frequency, end power transfer, or do something else. The instructions take the form of data packets, which are coupled through a series of filters connected to the IDTP9035’s Demodulator through the HPF pin. Recovering the data packets is the function of the Demodulator. Decoding and executing the packets is one of the functions of the MCU.

### MICRO-CONTROLLER UNIT (MCU)

The IDTP9035’s MCU processes the algorithm, commands, and data that control the power transferred to the receiver. The MCU is provided with RAM and ROM, and parametric trim and operational modes are set at the factory through the One-Time Programming (OTP) block, read by the MCU at power-up.

Note 1 - Refer to the WPC specification at <http://www.wirelesspowerconsortium.com/> for the most current information

## APPLICATIONS INFORMATION

The recommended applications schematic diagram is shown in Figure 9. The IDTP9035 operates with a 5V<sub>DC</sub> (±0.25V) input. The switching frequency varies from 110kHz to 205kHz. At the 205kHz limit the duty cycle is also changed to adjust the power transfer level. The power transfer is controlled via changes in the switching frequency and duty cycle. The base or TX-side has a series resonance circuit made of a WPC Type-A5 or A11 coil (~6.3μH) and a series resonant capacitor (~400nF) driven by a full-bridge inverter, as shown in Figure 7.

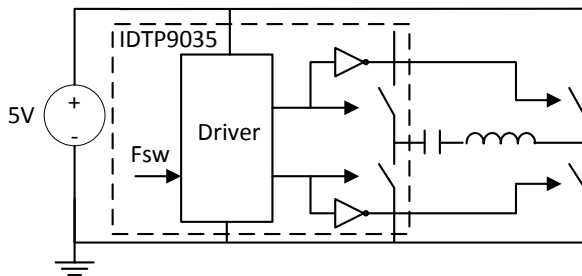

Figure 7. Full-Bridge inverter TX Coil Driver.

## EXTERNAL CHIP RESET and EN

The IDTP9035 can be externally reset by pulling the RESET pin to a logic high (above the V<sub>IH</sub> level).

The RESET pin is a dedicated high-impedance active-high digital input, and the effect is similar to the power-up reset function. Because of the internal low voltage monitoring scheme, the use of the external RESET pin is not mandatory. If desired, a manual external reset scheme can be added by connecting 5V to the RESET pin through a simple switch. When RESET is HIGH, the microcontroller's registers are set to the default configuration. When the RESET pin is released to a LOW, the microcontroller starts executing the code from the boot address.

If the particular application requires the IDTP9035 to be disabled, this can be accomplished with the EN pin. When the EN pin is pulled high, the device is suspended and placed in low current (sleep) mode. If pulled low, the device is active.

The current into EN is approximately equal to:

$$I(\overline{EN}) = \frac{V(\overline{EN} - 2V)}{300k}$$

or close to zero if V( $\overline{EN}$ ) is less than 2V.

## SYSTEM FEEDBACK CONTROL (WPC)

The IDTP9035 contains logic to demodulate and decode error packets sent by the mobile device (Rx-side), and adjusts power transfer accordingly. The IDTP9035 varies the switching frequency of the full-bridge inverter between 110kHz to 205 kHz to adjust power transfer. The mobile device controls the amount of power transferred via a communication link that exists from the mobile device to the base station. The mobile device (IDTP9020-based or another WPC-compliant receiver) communicates with the IDTP9035 via communication packets. Each packet has the following format:

Table 5 – Data Packet Format.

Preamble	Header	Message	Checksum

The overall system behavior between the transmitter and receiver follows the state machine diagram below:

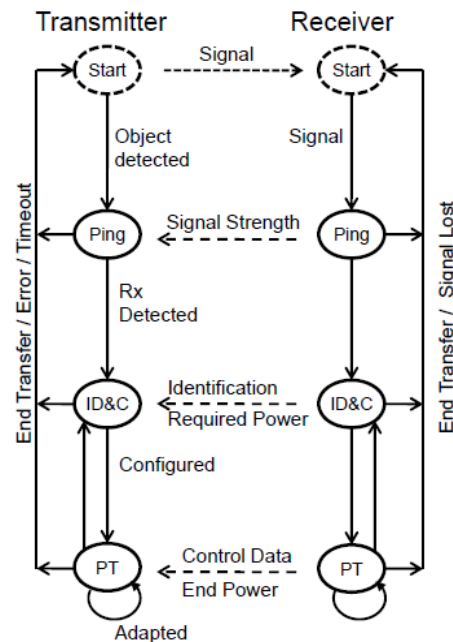

Figure 8. System state machine diagram

The IDTP9035 performs four phases: Selection, Ping, Identification & Configuration, and Power Transfer.

## START (SELECTION) PHASE

In this phase, the IDTP9035 operates in a low power mode to determine if a potential receiver has been placed on the coil surface prior to the PING state. Twice a second, the IDTP9035 applies a brief AC signal to its coil and listens for a response.



## PING PHASE

In this phase, the IDTP9035 applies a power signal at 175 kHz with a fixed 50% duty cycle and attempts to establish a communication link with a mobile device.

### Required packet(s) in PING:

1. Signal strength packet (0x01)

The mobile device must send a Signal Strength Packet within a time period specified by the WPC, otherwise the power signal is terminated and the process repeats.

The mobile device calculates the Signal Strength Packet value, which is an unsigned integer value between 0-255, based on this formula:

$$\text{Signal Strength Value} = \left( \frac{U}{U_{max}} \right) \cdot 256$$

where U is a monitored variable (i.e. rectified voltage/current/power) and  $U_{max}$  is a maximum value of that monitored variable expected during the digital ping phase at 175 kHz.

If the IDTP9035 does not detect the start bit of the header byte of the Signal Strength Packet during the Ping Phase, it removes the power signal after a delay. If a signal strength packet is received, the IDTP9035 goes to the Identification and Configuration Phase. If the IDTP9035 does not move to the Identification and Configuration Phase after receiving the signal strength packet, or if a packet other than a signal strength packet is received, then power is terminated.

## IDENTIFICATION AND CONFIGURATION (ID & Config)

In this phase, the IDTP9035 tries to identify the mobile device and collects configuration information.

### Required packet(s) in ID & Config:

1. Identification packet (0x71)
2. Extended Identification packet (0x81)\*
3. Configuration packet (0x51)

\* If Ext bit of 0x71 packet is set to 1.

Also, the IDTP9035 must correctly receive the following sequence of packets without changing the operating point (175 kHz @ 50% duty cycle):

1. Identification Packet (0x71)
2. Extended Identification (0x81)
  - a. Up to 7 optional Configuration Packets from the following set:
    - b. Power Control Hold-Off Packet (0x06)
    - c. Proprietary Packet (0x18 – 0xF2)
    - d. Reserved Packet
3. Configuration Packet (0x51)

If the IDTP9035 does not detect the start bit of the header byte of the next packet in the sequence within a WPC-specified time after receiving the stop bit of the checksum byte of the preceding Signal Strength Packet, then the Power Signal is removed after a delay. If a correct control packet in the above sequence is received late, or if control packets that are not in the sequence are received, the IDTP9035 removes the Power Signal after a delay.

## POWER TRANSFER PHASE

In this phase, the IDTP9035 adapts the power transfer to the receiver based on control data it receives in control error packets.

### Required packet(s) in Power Transfer:

1. Control Error Packet (0x03)
2. Rectified Power Packet (0x04)

For this purpose, the IDTP9035 may receive zero or more of the following Packets:

1. Control Error Packet (0x03)
2. Rectified Power Packet (0x04)
3. Charge Status Packet (0x05)
4. End Power Transfer Packet (0x02)
5. Any Proprietary Packet
6. Any Reserved Packets

## Product Datasheet

If the IDTP9035 does not correctly receive the first Control Error Packet in time, it removes the Power Signal after a delay. Because Control Error Packets come at a regular interval, the IDTP9035 expects a new Control Error Packet after receiving the stop bit of the checksum byte of the preceding Control Error Packet. If that does not happen, then the IDTP9035 removes the Power Signal. Similarly, the IDTP9035 must receive a Rectified Power Packet within a WPC-specified time after receiving the stop bit of the checksum byte of the Configuration Packet (which was received earlier in the *identification and configuration* phase). Otherwise, it removes the Power Signal.

Upon receiving a Control Error value, the IDTP9035 makes adjustments to its operating point after a delay to enable the Primary Coil current to stabilize again after communication.

If the IDTP9035 correctly receives a Packet that does not comply with the sequence, then it removes the Power Signal.

### **FOREIGN OBJECT DETECTION (FOD)**

In addition to over-temperature protection, the IDTP9035 employs a proprietary FOD technique which detects foreign objects placed on the base station. The FOD algorithm is multi-layered and may issue warnings and/or change device operation depending on the severity of the issue.

FOD is an optional feature that is not included in the standard firmware. Please contact IDT to incorporate this feature into a specific product, indicating volume and business case.

## APPLICATIONS INFORMATION

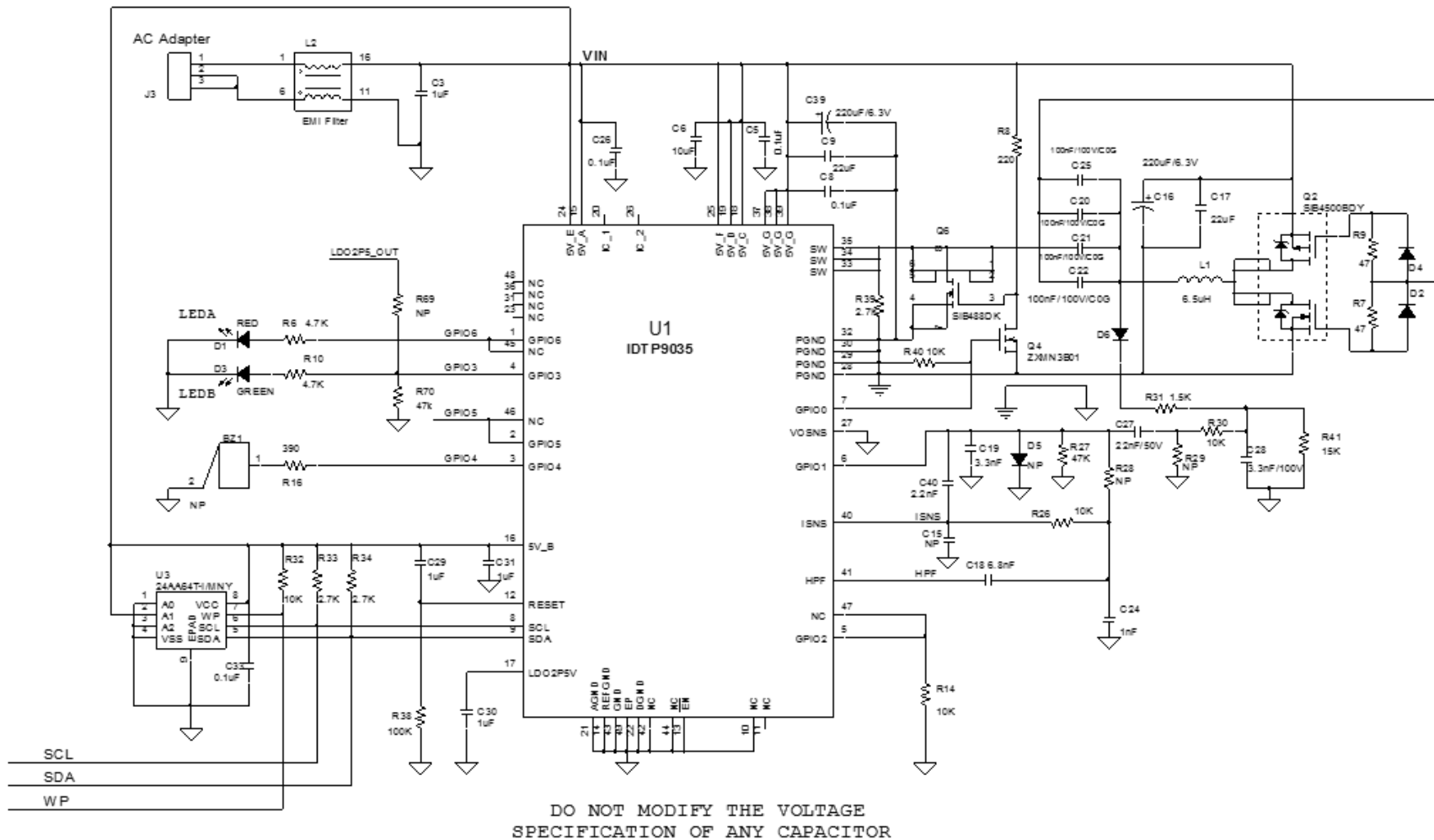

Figure 9. IDTP9035 WPC “Qi” Compliance Schematic (See IDTP9035 Evaluation Kit User Manual for complete details)

Table 6. IDTP9035 WPC “Qi” Compliance Bill of Materials

Item	Quantity	Reference	Part	Part Number	PCB Footprint
1	1	BZ1	NP	PS1240P02CT3 (Optional)	buzz_ps1240
2	4	C3,C29,C30,C31	1uF	C1608X7R1E105K	603
3	4	C5,C8,C26,C33	0.1uF	GRM188R71H104KA93D	603
4	1	C6	10uF	C2012X5R1E106M	805
5	2	C9,C17	22uF	GRM31CR61E226KE15L	1206
6	1	C15	NP	NP	402
7	2	C16,C39	220uF/6.3V	6TPF220M9L	POSCON_SVPF
8	1	C18	6.8nF	C1005X7R1H682K	402
9	1	C19	3.3nF	C1005X7R1H332K	402
10	4	C20,C21,C22,C25	100nF/100V/COG	C4532C0G2A104J	1812
11	1	C24	1nF	C1005X7R1H102K	402
12	1	C27	22nF/50V	C1608X7R1H223K	603
13	1	C28	3.3nF/100V	C1608X7R2A332K	603
14	1	C40	2.2nF	UMK105B7222KV-F	402
15	1	D1	RED	L29K-G1J2-1-0-2-R18-Z (Optional)	0603_DIODE
16	2	D2,D4	Schottky	PMEG2020EJ	SOD323
17	1	D3	GREEN	LG L29K-G2J1-24-Z (Optional)	0603_DIODE
18	1	D5	NP	NP	sod523
19	1	D6	Diode	BAV21W-7-F	SOD123
20	1	J1	I2C connector	5103308-1	LOPRO8PIN01INREVB
21	1	J3	AC Adapter	PJ-018AH	CONN_POWER_JACK5_5MM
22	1	L1	6.5uH	WT-505060-10K2-A11-G	IND_Y31-60014F
23	1	L2	EMI Filter	NP	clcft_na6054
24	1	Q2	SiB4500BDY	SI4500BDY-T1-E3	soic8
25	1	Q4	ZXMN3B01	ZXMN3B01FTA	SOT23_3
26	1	Q6	SiB488DK	SIB488DK-T1-GE3	sc75_6ld_fet
27	1	RESET	TEST POINT	NP	test_pt30dpad
28	2	R6,R10	4.7K	ERJ-2GEJ472X	402
29	2	R7,R9		47 ERJ-3GEYJ470V	603
30	1	R8		220 ERJ-3GEYJ221V	603
31	3	R14,R32,R40	10K	ERJ-3GEYJ103V	402
32	1	R16		390 ERJ-3GEYJ391V	603
33	1	R26	10K	RC0402FR-0710KL	402
34	1	R27	47K	ERJ-2GEJ473X	402
35	2	R28,R29	NP	NP	603
36	1	R30	10K	ERJ-3EKF1002V	603
37	1	R31	1.5K	ERJ-3EKF1501V	603
38	3	R33,R34,R39	2.7K	ERJ-2GEJ272X	402
39	1	R38	100K	ERJ-2GEJ104X	402
40	1	R41	15K	ERJ-3GEYJ153V	603
41	2	R42,R43		0 ERJ-8GEY0R00V	1206
42	1	U1	IDTP9035	IDTP9035	NTG_48LD_6X6MM_0P4PITCH
43	1	U3	IC EEPROM 64KBIT 400KHZ	24AA64T-I/MNY	DFN8

**Note 1:** Recommended capacitor temperature/dielectric and voltage ratings: 100V capacitors are recommended because >50Vp-p voltage levels may appear on the resonance capacitors as stated in the WPC specification. COG/NPO-type capacitor values stay relatively constant with voltage while X7R and X5R ceramic capacitor values change from -40% to over -80%, with the applied voltage. The decision to use lower voltage 50V capacitors or other type temperature/dielectric capacitors is left to the end user.

## External Components

The IDTP9035 requires a minimum number of external components for proper operation (see the BOM in Table

10). A complete design schematic compliant to the WPC “Qi” standard is given in Figure 9. It includes WPC “Qi” LED and buzzer signaling.

## I<sup>2</sup>C Communication

The IDTP9035 includes an I<sup>2</sup>C block which can support either I<sup>2</sup>C Master or I<sup>2</sup>C Slave operation. After power-on-reset (POR), the IDTP9035 will initially become I<sup>2</sup>C Master for the purpose of uploading firmware from an external memory device, such as an EEPROM. The I<sup>2</sup>C Master mode on the IDTP9035 does not support multi-master mode, and it is important for system designers to avoid any bus master conflict until the IDTP9035 has finished any firmware uploading and has released control of the bus as I<sup>2</sup>C Master. After any firmware uploading from external memory is complete, and when the IDTP9035 begins normal operation, the IDTP9035 is normally configured by the firmware to be exclusively in I<sup>2</sup>C Slave mode.

For maximum flexibility, the IDTP9035 tries to communicate with the first address on the EEPROM at 100kHz. If no ACK is received, communication is attempted at the other addresses at 300kHz.

## EEPROM

The IDTP9035 requires an external EEPROM memory chip, pre-programmed with a standard start-up program that is automatically loaded when 5V power is applied. The IDTP9035 uses I<sup>2</sup>C slave address 0x52 to access the EEPROM. The IDTP9035 slave address is 0x39. The EEPROM can be reprogrammed to suit the needs of a specific application using the IDTP9035 software tool (see the IDTP9035-Qi Demo Board User Manual for complete details). A serial 8Kbyte (8Kx8 64Kbits) external EEPROM is sufficient.

If the standard firmware is not suitable for the application, custom ROM options are possible. Please contact IDT sales for more information. IDT will provide the appropriate image in the format best suited to the application.

## Overview of Standard GPIO Usage

There are 7 GPIO's on the IDTP9035 transmitter IC, of which three are available for use as follows:

- GPIO3: Green LED\_B to indicate standby, power transfer, and power complete; see Table 7.

- GPIO4: AC or DC buzzer (optional) with resistor options for different buzzer configurations (Not Yet Available).
- GPIO6: Red LED\_A to indicate standby, fault conditions, and FOD warnings. Table 7 lists how the red and green LEDs can be used to display information about the IDTP9035's operating modes. The table also includes information about external resistors or internal pull up/down options to select LED modes. Eight of the ten LED modes (those associated with advanced charging modes) are currently designated as “Future” modes.

## LED FUNCTIONS

Two GPIOs are used to drive LEDs which indicate, through various on/off and illumination options, the state of charging and some possible fault conditions.

A red LED indicates various Fault and FOD (“Foreign Object Detection”) states. The green LED indicates Power Transfer and Charge Complete state information. Upon power up, the two LEDs together may optionally indicate the Standby State and remain in this state until another of the defined Operational States occurs

As shown in Figure 12, one or two resistors configure the defined LED option combinations. The DC voltage set in this way is read one time during power-on to determine the LED configuration. To avoid interfering with the LED operation, the useful DC voltage range must be limited to not greater than 1Vdc.

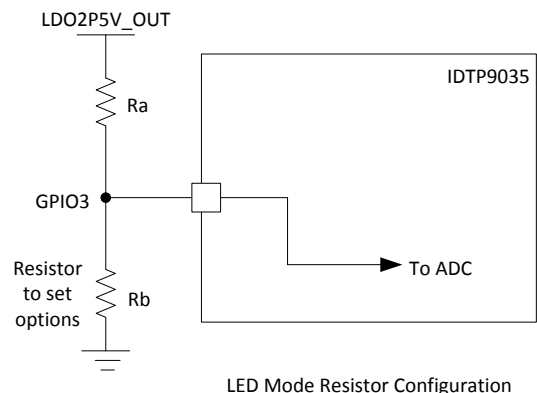

**Figure 10. IDTP9035 LED Resistor Options.**

### LED Pattern Operational Status Definitions:

Blink Slow, Fast, repeat.

**Table 7 – IDTP9035 LED Resistor Optioning (Not all options supported, shaded rows are for future development).**

LED Control Option	LED Select Resistor Value	Description	LED #/ Color	Operational Status				FOD Warning
				Standby	Transfer	Complete	Condition	
1	Pull Down	Standby LEDs ON	LED1- Green	ON	BLINK SLOW	ON	OFF	OFF
			LED2- Red	ON	OFF	OFF	ON	BLINK FAST
2	R1	Standby LEDs ON plus	LED1- Green	ON	BLINK SLOW	ON	OFF	OFF
			LED2- Red	ON	OFF	OFF	ON	BLINK FAST
3	R2	Standby LEDs ON plus	LED1- Green	ON	BLINK SLOW	ON	OFF	OFF
			LED2- Red	ON	OFF	OFF	ON	BLINK FAST
4	R3	Standby LEDs ON plus	LED1- Green	ON	BLINK SLOW	ON	OFF	OFF
			LED2- Red	ON	OFF	OFF	ON	BLINK FAST
5	R4	Standby LEDs ON plus	LED1- Green	ON	BLINK SLOW	ON	OFF	OFF
			LED2- Red	ON	OFF	OFF	ON	BLINK FAST
6	Pull Up	Standby LEDs OFF	LED1- Green	OFF	BLINK SLOW	ON	OFF	OFF
			LED2- Red	OFF	OFF	OFF	ON	BLINK FAST
7	R5	Standby LEDs OFF plus	LED1- Green	OFF	BLINK SLOW	ON	OFF	OFF
			LED2- Red	OFF	OFF	OFF	ON	BLINK FAST
8	R6	Standby LEDs OFF plus	LED1- Green	OFF	BLINK SLOW	ON	OFF	OFF
			LED2- Red	OFF	OFF	OFF	ON	BLINK FAST
9	R7	Standby LEDs OFF plus	LED1- Green	OFF	BLINK SLOW	ON	OFF	OFF
			LED2- Red	OFF	OFF	OFF	ON	BLINK FAST
10	R8	Standby LEDs OFF plus	LED1- Green	OFF	BLINK SLOW	ON	OFF	OFF
			LED2- Red	OFF	OFF	OFF	ON	BLINK FAST

*R1-R8 are created using combination of two 1% resistors.*

Designates Future Option

## Buzzer Function

An optional buzzer feature is supported on GPIO4. The default configuration is an “AC” buzzer. The signal is created by toggling GPIO4 active-high/active-low at a 2kHz frequency.

### Buzzer Action: Power Transfer Indication

The IDTP9035 supports audible notification when the device operation successfully reaches the Power Transfer state. The duration of the power transfer indication sound is 400ms.

The latency between reaching the Power Transfer state and sounding the buzzer does not exceed 500ms. Additionally, the buzzer sound is concurrent within  $\pm 250$ ms of any change to the LED configuration indicating the start of power transfer.

### Buzzer Action: No Power Transfer due to Foreign Object Detected (FOD)

When a major FOD situation is detected such that, for safety reasons, power transfer is not initiated, or that

power transfer is terminated, the buzzer is sounded in a repeating sequence:

For 30 seconds: 400ms ON, 800ms OFF, repeat  
 Next 30 seconds: Off/silence (but no change to LED on/off patterns)  
 The pattern is repeated while the error condition exists

The buzzer is synchronized with the FOD LED such that the 400ms on tone corresponds with the red LED illumination and 800ms off (no sound) corresponds with the red LED being off.

## Decoupling/Bulk Capacitors

As with any high-performance mixed-signal IC, the IDTP9035 must be isolated from the system power supply noise to perform optimally. A decoupling capacitor of 0.1 $\mu$ F must be connected between each power supply and the PCB ground plane as close to these pins as possible. For optimum device performance, the decoupling capacitor must be mounted on the component side of the PCB. Avoid the use of vias in the decoupling circuit. Additionally, medium value capacitors in the 22 $\mu$ F range must be used at the 5V\_G input to minimize ripple voltage



and voltage droop due to the large current requirements of the Full-Bridge driver. At least four 22 $\mu$ F capacitors must be used close to the IN pins of the device. Since the operating voltage is 4.75V to 5.25V, the value of the capacitors will decrease due to capacitance-to-applied voltage characteristics of the commonly-used ceramic dielectrics. For example, a 22 $\mu$ F X7R 6.3V capacitor's value is actually 6 $\mu$ F when operating at 5V.

There must also be two 220 $\mu$ F 6.3V OS-CON or POSCAP bulk capacitors, one connected at the node where the input voltage to the board is applied, and another at the power input to the external Half-Bridge. OS-CON and POSCAP capacitors have much lower ESR than aluminum electrolytic capacitors and will reduce voltage ripple.

## ADC Considerations

The GPIO pins are connected internally to a successive approximation ADC with a multiplexed input. The GPIO pins that are connected to the ADC have limited input range, so attention must be paid to the maximum VIN (2.5V). 0.01 $\mu$ F decoupling capacitors can be added to the GPIO inputs to minimize noise.

## WPC TX-A5 or A11 Coil

The SW pin connects to a series-resonance circuit comprising a WPC Type-A5 or A11 coil (~6.5 $\mu$ H) and a series resonant capacitor (~400nF), as shown in Figure 9. The inductor serves as the primary coil in a loosely-coupled transformer, the secondary of which is the inductor connected to the power receiver (IDTP9020 or another).

The TX-A5 or A11 power transmitter coil is mounted on a ferrite shield to reduce EMI. The coil assembly can be mounted next to the IDTP9035. Either ground plane or grounded copper shielding can be added beneath the ferrite shield for added reduction in radiated electrical field emissions. The coil ground plane/shield must be connected to the IDTP9035 ground plane by a single trace.

## Resonance Capacitors

Because of the need to keep the resonant frequency of the output circuit stable, the resonance capacitors must be COG type dielectric and have a DC rating to 100V. The highest-efficiency combination is four 100nF in parallel to

get the lowest ESR. The part numbers are shown in Table 6.

## LDO

### Input Capacitor

The input capacitors must be located as physically close as possible to the power pin (5V\_C) and power ground (GND). Ceramic capacitors are recommended for their higher current operation and small profile. Also, ceramic capacitors are inherently more capable than are tantalum capacitors to withstand input current surges from low impedance sources such as batteries used in portable devices. Typically, 10V- or 16V-rated capacitors are required. The recommended external components are shown in Table 10.

### Output Capacitor

For proper load voltage regulation and operational stability, a capacitor is required on the output of the LDO. The output capacitor must be placed as close to the device and power (PGND) pins as possible. Since the LDO has been designed to function with very low ESR capacitors, a ceramic capacitor is recommended for best performance.

## PCB Layout Considerations

- For optimum device performance and lowest output phase noise, the following guidelines must be observed. Please contact IDT for Gerber files that contain the recommended board layout.
- As for all switching power supplies, especially those providing high current and using high switching frequencies, layout is an important design step. If layout is not carefully done, the regulator could show instability as well as EMI problems. Therefore, use wide and short traces for high current paths.
- The 0.1 $\mu$ F decoupling capacitors must be mounted on the component side of the board as close to the VDD pin as possible. Do not use vias between decoupling capacitors and VDD pins. Keep PCB traces to each VDD pin and to ground vias as short as possible.
- To optimize board layout, place all components on the same side of the board and limit the use of vias. Route other signal traces away from the IDTP9035. For example, use keepouts for signal traces routing on inner and bottom layers underneath the device.

## Product Datasheet

- The NQG48 6.0 mm x 6x0 mm x 75mm 48L package has an inner thermal pad which requires blind assembly. It is recommended that a more active flux solder paste be used such as Alpha OM-350 solder paste from Cookson Electronics (<http://www.cooksonsemi.com>). Please contact IDT for Gerber files that contain recommended solder stencil design.
- The package center exposed pad (EP) must be reliably soldered directly to the PCB. The center land pad on the PCB (set 1:1 with EP) must also be tied to the board ground plane, primarily to maximize thermal performance in the application. The ground connection is best achieved using a matrix of PTH vias embedded in the PCB center land pad for the NTG48. The PTH vias perform as thermal conduits to the ground plane (thermally, a heat spreader) as well as to the solder side of the board. There, these thermal vias embed in a copper fill having the same dimensions as the center land pad on the component side. Recommendations for the via finished hole-size and array pitch are 0.3mm to 0.33mm and 1.3mm, respectively.
- Layout and PCB design have a significant influence on the power dissipation capabilities of power management ICs. This is due to the fact that the surface mount packages used with these devices rely heavily on thermally conductive traces or pads to transfer heat away from the package. Appropriate PCB layout techniques must then be used to remove the heat due to device power dissipation. The following general guidelines will be helpful in designing a board layout for lowest thermal resistance:
  1. PCB board traces with large cross sectional areas remove more heat. For optimum results, use large area PCB patterns with wide and heavy (2 oz.) copper traces, placed on the top layer of the PCB.
  2. In cases where maximum heat dissipation is required, use double-sided copper planes connected with multiple vias.
  3. Thermal vias are needed to provide a thermal path to the inner and/or bottom layers of the PCB to remove the heat generated by device power dissipation.
  4. Where possible, increase the thermally conducting surface area(s) openly exposed to moving air, so that heat can be removed by convection (or forced air flow, if available).
- 5. Do not use solder mask or place silkscreen on the heat-dissipating traces/pads, as they increase the net thermal resistance of the mounted IC package.

## Power Dissipation/Thermal Requirements

The IDTP9035 is offered in a TQFN-48L package. The maximum power dissipation capability is 2W, limited by the die's specified maximum operating junction temperature,  $T_J$ , of 125°C. The junction temperature rises with the device power dissipation based on the package thermal resistance. The package offers a typical thermal resistance, junction to ambient ( $\theta_{JA}$ ), of 31°C/W when the PCB layout and surrounding devices are optimized as described in the PCB Layout Considerations section. The techniques as noted in the PCB Layout section need to be followed when designing the printed circuit board layout, as well as the placement of the IDTP9035 IC package in proximity to other heat generating devices in a given application design. The ambient temperature around the power IC will also have an effect on the thermal limits of an application. The main factors influencing  $\theta_{JA}$  (in the order of decreasing influence) are PCB characteristics, die/package attach thermal pad size, and internal package construction. Board designers should keep in mind that the package thermal metric  $\theta_{JA}$  is impacted by the characteristics of the PCB itself upon which the TQFN is mounted. For example, in a still air environment, as is often the case, a significant amount of the heat that is generated (60 - 85%) sinks into the PCB. Changing the design or configuration of the PCB changes impacts the overall thermal resistivity and, thus, the board's heat sinking efficiency.

Implementation of integrated circuits in low-profile and fine-pitch surface-mount packages typically requires special attention to power dissipation. Many system-dependant issues such as thermal coupling, airflow, added heat sinks, and convection surfaces, and the presence of other heat-generating components, affect the power-dissipation limits of a given component.

Three basic approaches for enhancing thermal performance are listed below:

1. Improving the power dissipation capability of the PCB design
2. Improving the thermal coupling of the component to the PCB
3. Introducing airflow into the system



First, the maximum power dissipation for a given situation must be calculated:

$$P_{D(MAX)} = (T_{J(MAX)} - T_A) / \theta_{JA}$$

Where:

$P_{D(MAX)}$  = Maximum Power Dissipation (W)

$\theta_{JA}$  = Package Thermal Resistance ( $^{\circ}C/W$ )

$T_{J(MAX)}$  = Maximum Device Junction Temperature ( $^{\circ}C$ )

$T_A$  = Ambient Temperature ( $^{\circ}C$ )

The maximum recommended junction temperature ( $T_{J(MAX)}$ ) for the IDTP9035 device is  $150^{\circ}C$ . The thermal resistance of the 48-pin NQG package (NGQ48) is optimally  $\theta_{JA}=30^{\circ}C/W$ . Operation is specified to a maximum steady-state ambient temperature ( $T_A$ ) of  $85^{\circ}C$ . Therefore, the maximum recommended power dissipation is:

$$P_{D(Max)} = (150^{\circ}C - 85^{\circ}C) / 30^{\circ}C/W \cong 2 \text{ Watt}$$

## Thermal Overload Protection

The IDTP9035 integrates thermal overload shutdown circuitry to prevent damage resulting from excessive thermal stress that may be encountered under fault conditions. This circuitry will shut down or reset the device if the die temperature exceeds  $140^{\circ}C$ . To allow the maximum load current on each regulator and resonant transmitter, and to prevent thermal overload, it is important to ensure that the heat generated by the IDTP9035 is dissipated into the PCB. The package exposed paddle must be soldered to the PCB, with multiple vias evenly distributed under the exposed paddle and exiting the bottom side of the PCB. This improves heat flow away from the package and minimizes package thermal gradients.

## Special Notes

### NQG TQFN-48 Package Assembly

Note 1: Unopened Dry Packaged Parts have a one year shelf life.

Note 2: The HIC indicator card for newly opened Dry Packaged Parts should be checked. If there is any moisture content, the parts must be baked for minimum of 8 hours at  $125^{\circ}C$  within 24 hours of the assembly reflow process.

## PACKAGE OUTLINE DRAWING

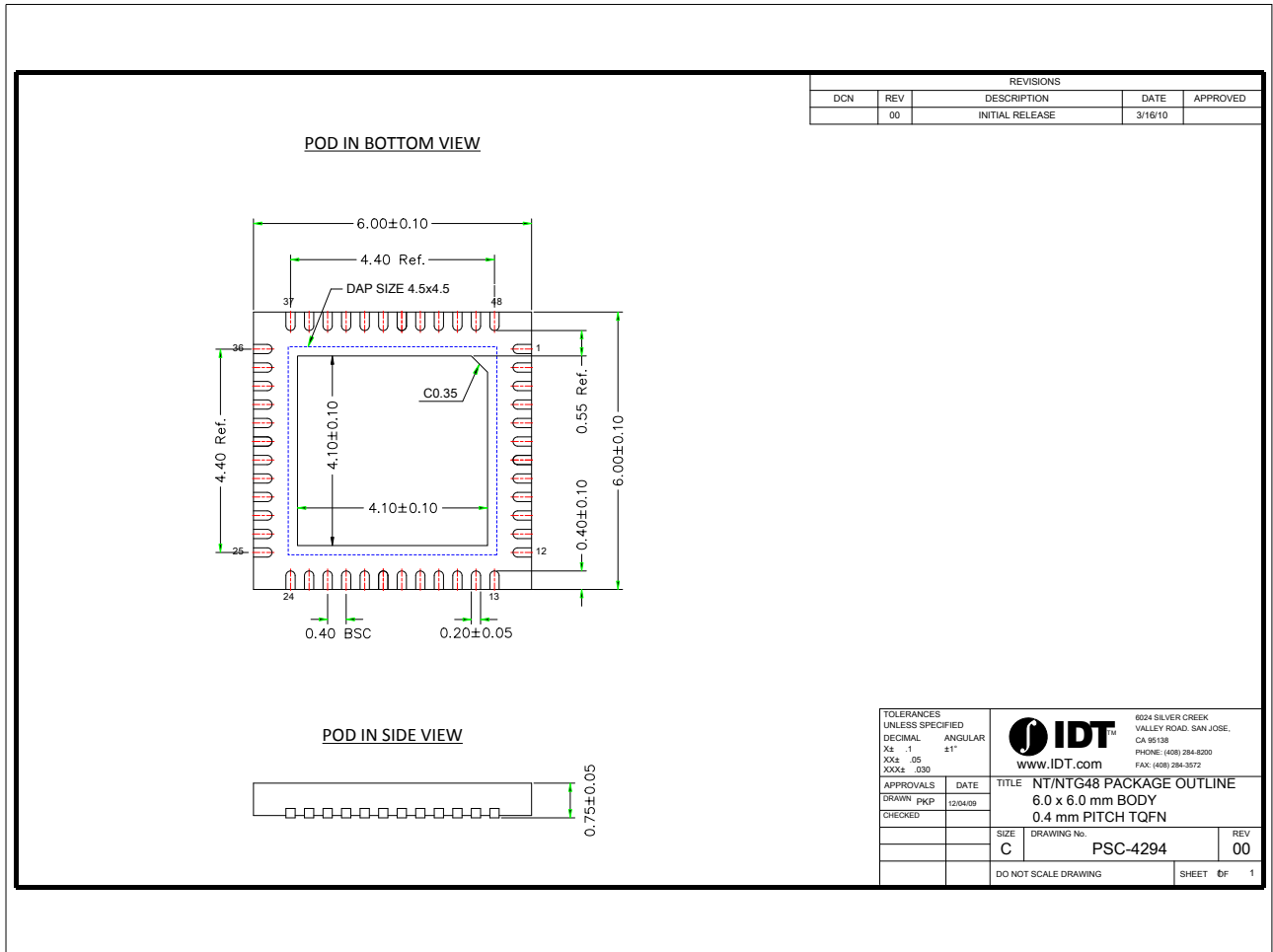

Figure 11. IDTP9035 Package Outline Drawing (NTG48 TQFN-48L 6.0 mm x 6.0 mm x 0.75 mm48L, 0.4mm pitch)

## ORDERING GUIDE

Table 8. Ordering Summary

PART NUMBER	MARKING	PACKAGE	AMBIENT TEMP. RANGE	SHIPPING CARRIER	QUANTITY
P9035-0NTGI	P9035NTG	NTG48 - TQFN-48 6x6x0.75mm	-40°C to +85°C	Tape or Canister	25
P9035-0NTGI8	P9035NTG	NTG48 - TQFN-48 6x6x0.75mm	-40°C to +85°C	Tape and Reel	2,500



[www.IDT.com](http://www.IDT.com)

6024 Silver Creek Valley Road  
San Jose, California 95138

Tel: 800-345-7015

DISCLAIMER Integrated Device Technology, Inc. (IDT) and its subsidiaries reserve the right to modify the products and/or specifications described herein at any time and at IDT's sole discretion. All information in this document, including descriptions of product features and performance, is subject to change without notice. Performance specifications and the operating parameters of the described products are determined in the independent state and are not guaranteed to perform the same way when installed in customer products. The information contained herein is provided without representation or warranty of any kind, whether express or implied, including, but not limited to, the suitability of IDT's products for any particular purpose, an implied warranty of merchantability, or non-infringement of the intellectual property rights of others. This document is presented only as a guide and does not convey any license under intellectual property rights of IDT or any third parties. IDT's products are not intended for use in life support systems or similar devices where the failure or malfunction of an IDT product can be reasonably expected to significantly affect the health or safety of users. Anyone using an IDT product in such a manner does so at their own risk, absent an express, written agreement by IDT.

Integrated Device Technology, IDT and the IDT logo are registered trademarks of IDT. Other trademarks and service marks used herein, including protected names, logos and designs, are the property of IDT or their respective third party owners.

© Copyright 2012. All rights reserved.