

THIS DRAWING IS UNPUBLISHED. RELEASED FOR PUBLICATION, 19 .
 © COPYRIGHT 19 BY AMP INCORPORATED. ALL INTERNATIONAL RIGHTS RESERVED.

LOC	DIST	P	F	ZONE	LTR	DESCRIPTION	DATE	APPD
G	14				B	REVISED PER 0720-0961-96	06JUN96	OK MJ5

METRIC
 DIMENSIONS LISTED IN mm [INCHES]

AMP WIRE RANGE	E13288 Listed
22-16 AWG STRANDED	22-16 AWG STRANDED
LR7189 Certified	MILITARY P/N AND CLASS
NOT CERTIFIED	NOT APPLICABLE

△ STAMP AMP 22-18* APPROX AS SHOWN
 22-16 TERMINALS ARE STAMPED 22-18 IN
 ACCORDANCE WITH MILITARY SPECIFICATION
 MIL-T-7928; COMMERCIAL WIRE RANGE IS 22-16

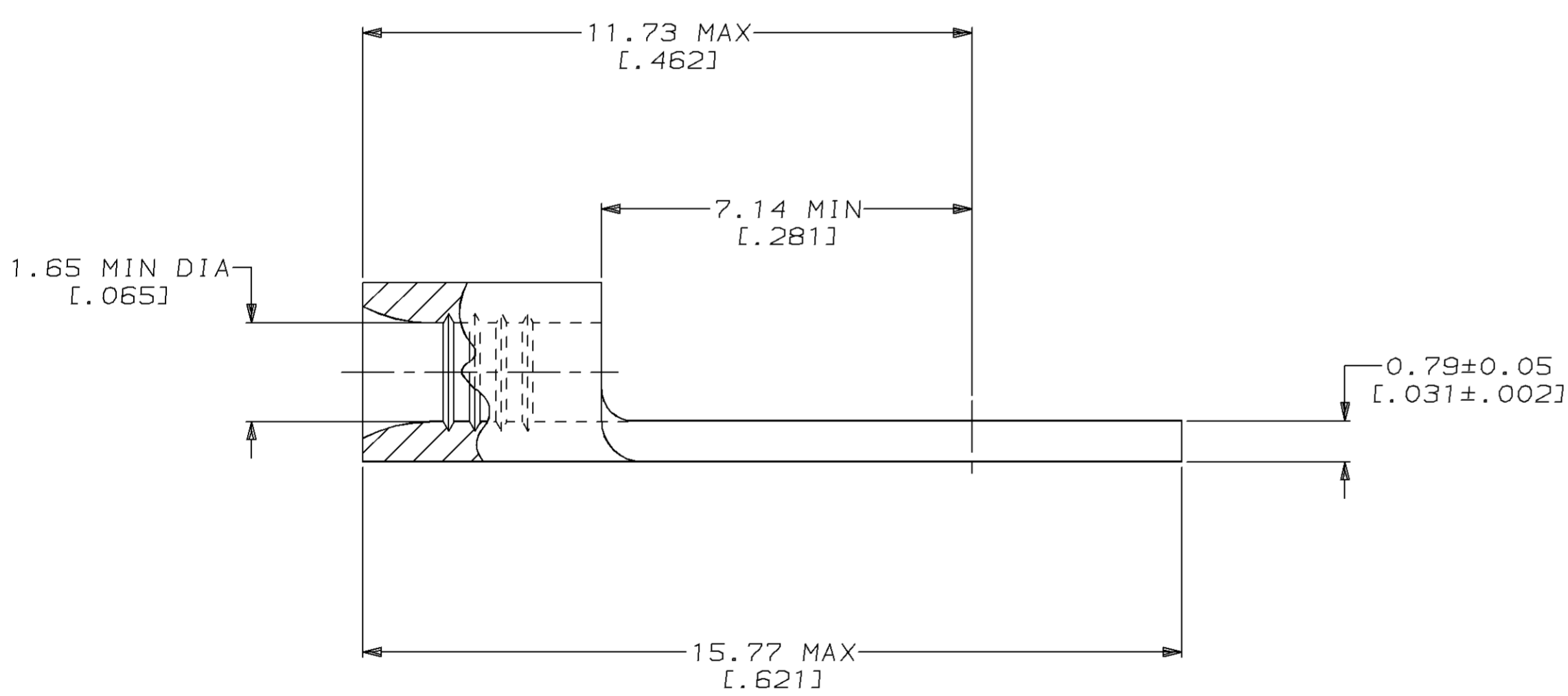
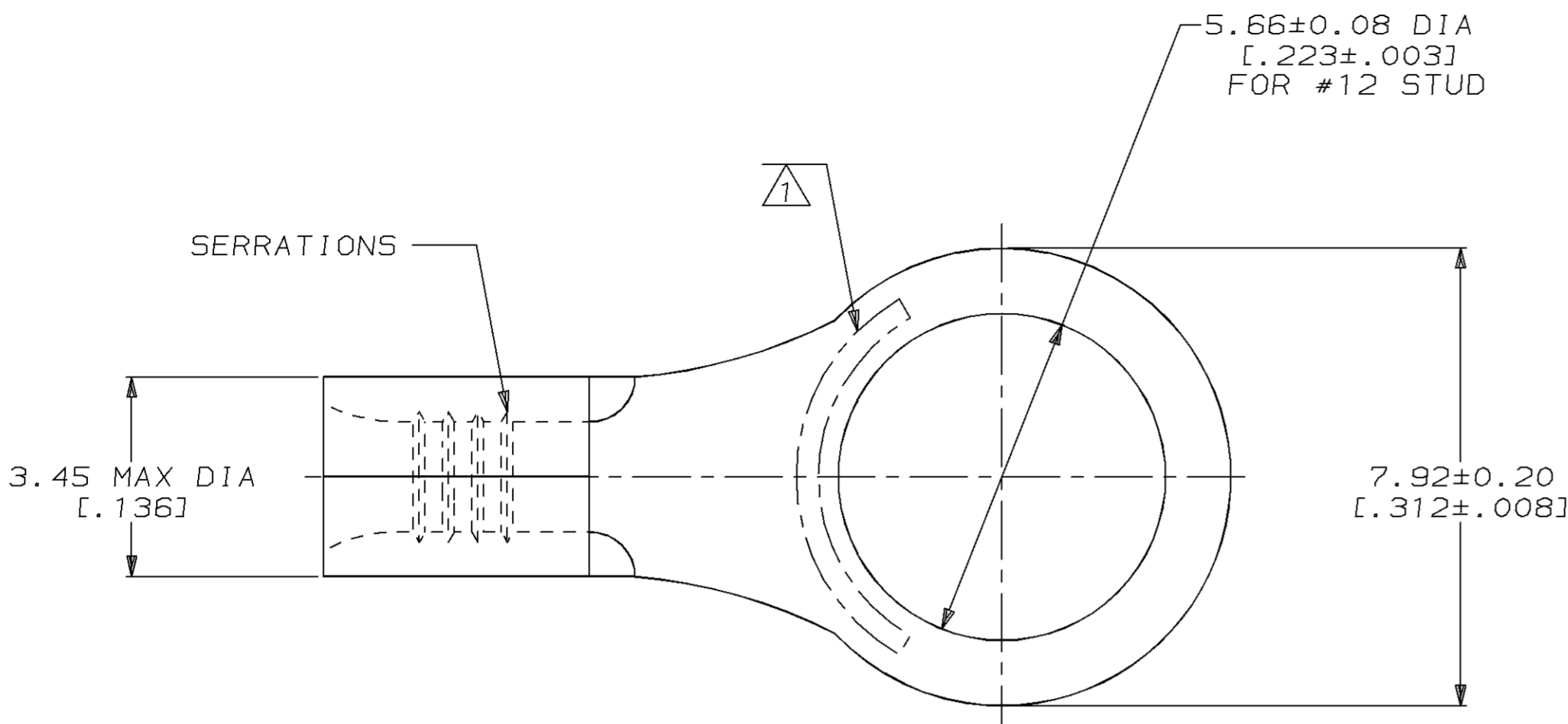

OBsolete	-5000	ON TAPE	2-30694-1
	----	LOOSE PIECE	30694
QUANTITY		PACKAGE TYPE	PART NO

AMP INCORPORATED
CUSTOMER SERVICE SYSTEMS

FOR ADDITIONAL
 PRODUCT INFORMATION OR
 COPIES OF DRAWINGS
 AND TECHNICAL DOCUMENTS

FOR APPLICATION
 TOOLING INFORMATION

FOR ORDER ENTRY

PRODUCT INFORMATION CENTER
 1-800-522-6752

TOOLING ASSISTANCE CENTER
 1-800-722-1111

1-800-526-5142

MAX RECOMMENDED OPERATING
 TEMPERATURE:
 170°C MAX

VOLTAGE RATING:
 NOT APPLICABLE

WIRE CROSS SECTIONAL AREA RANGE:
 0.26-1.65mm² [509-3,260] CIR MILS
 STRANDED

THIS DRAWING IS A CONTROLLED DOCUMENT FOR
 AMP INCORPORATED. IT IS SUBJECT TO CHANGE
 AND THE CONTROLLING ENGINEERING ORGANIZATION
 SHOULD BE CONTACTED FOR THE LATEST REVISION.

DO NOT SCALE PRINT.
 UNLESS SPECIFIED
 DIMENSIONS IN mm [INCHES]
 TOLERANCES ON:
 2 PLC DEC ± -
 3 PLC DEC ± -
 ANGLES ± -

MATERIAL
 COPPER PER
 ASTM B-152
 ANNEALED

FINISH
 TIN PLATE
 0.00254 [0.000100] MIN
 THK PER MIL-T-10727

DR 2-3-93
 TA BRINKMAN

CHK 2-3-93
 DA PATTERSON

APPD 2-3-93
 DE MILLER

APPD 2-3-93
 JL MECKLEY

PRODUCT SPEC
 -

APPLICATION SPEC
 -

WEIGHT
 -

AMP AMP Incorporated
 Harrisburg, PA 17105-3608

NAME
**TERMINAL, RING TONGUE,
 BUDGET**

SIZE
 C 00779

CAGE CODE
 00779

DRAWING NO
 C=30694

SCALE 10:1

SHEET 1 OF 1