

THIS DRAWING IS UNPUBLISHED. RELEASED FOR PUBLICATION, 19
 © COPYRIGHT 19 BY AMP INCORPORATED. ALL INTERNATIONAL RIGHTS RESERVED.

LOC	DIST	P	F	REVISIONS				
AF	50			ZONE	LTR	DESCRIPTION	DATE	APPD
					R	REV PER 0710-0231-94	17/AUG/94	RB/NN

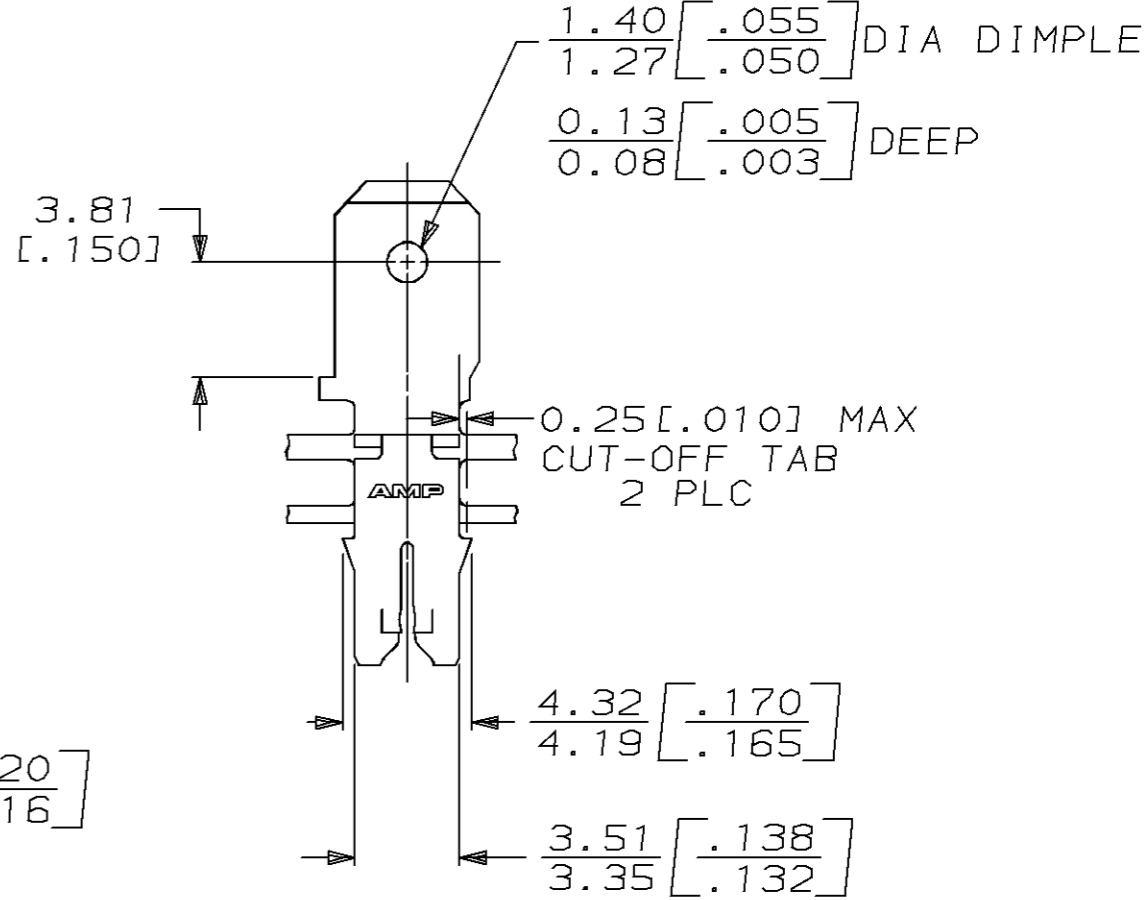
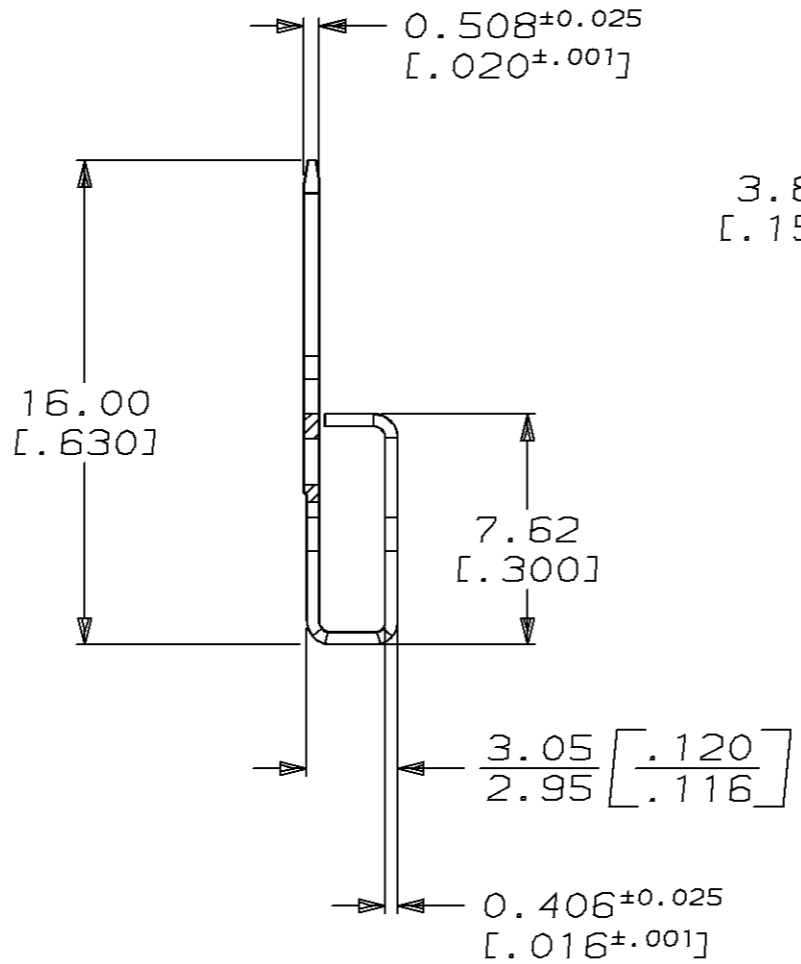
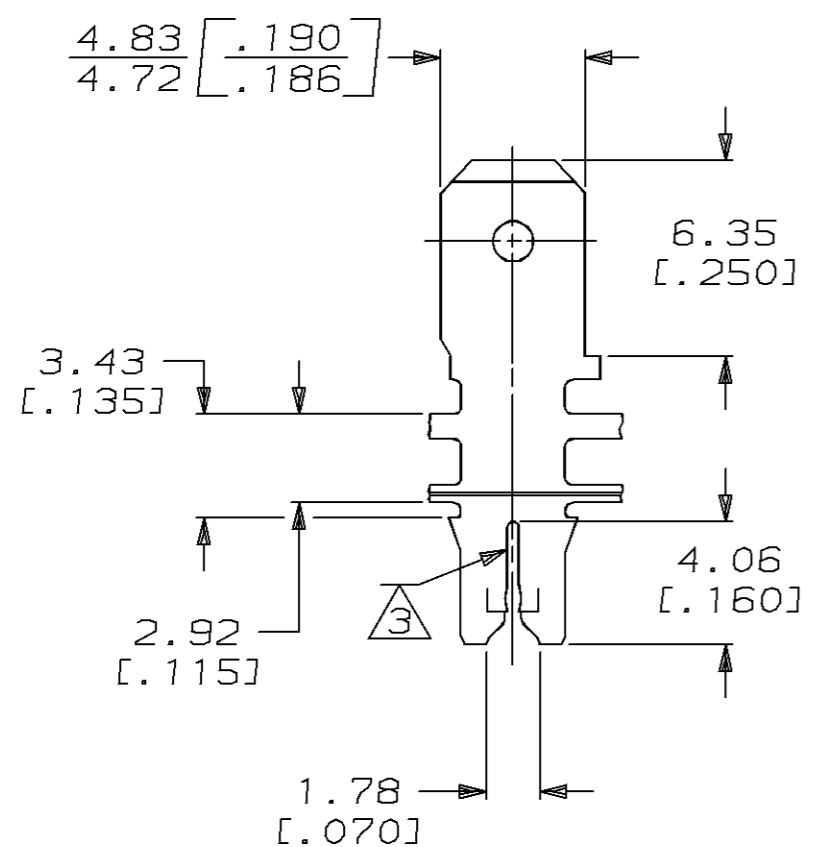

1 CONTINUOUS STRIP ON REELS WITH TERMINALS LOCATED ON 5.59 [.220] CENTERS

3 SLOT TERMINATES A SINGLE MAGNET WIRE ONLY, COPPER 0.64-0.81mm [#22-#20] AWG

2 AFTER INSERTION INTO PLASTIC HOLDER TAB PORTION MUST BE BENT OVER 45° TO 90° OR POTTED-IN TO PREVENT PULL-OUT WHEN MATING RECEPTACLE IS DISCONNECTED



VARNISH RESIST OVER TIN PL		62511-2
TIN PL 0.002032 [.000080] MIN PER MIL-T-10727		62511-1
FINISH		PART NO
DO NOT SCALE PRINT. UNLESS SPECIFIED DIMENSIONS IN mm [INCHES] TOLERANCES ON: 2 PLC DEC ± - 3 PLC DEC ± 0.25 [.010] ANGLES ± -	DR 12/4/89 D.K. SCHRUM CHK 12/19/89 M.S. FEHER APPD 12/19/89 N.E. NEFF APPD 12/19/89 T.L. SHUTTER PRODUCT SPEC 108-2012	AMP AMP INCORPORATED Harrisburg, Pa. 17105 NAME TAB, .187 FASTON™ MAG-MATE™
MATERIAL #4M HARD PRE-MILLED BRASS	APPLICATION SPEC 114-2046	
FINISH SEE TABLE	WEIGHT -	SIZE B CAGE CODE 00779 DRAWING NO 62511 SCALE 4:1 SHEET 1 OF 1