

THIS DRAWING IS UNPUBLISHED. RELEASED FOR PUBLICATION ,19
 © COPYRIGHT 19 BY AMP INCORPORATED. ALL INTERNATIONAL RIGHTS RESERVED.

LOC	DIST	P	F	ZONE	LTR	DESCRIPTION	DATE	APPD
F1	25				L	REV; EC 0N20-0055-97	16SEP97	DS EH
					L1	REVISED PER ECO-09-020774	25AUG09	KK AEG

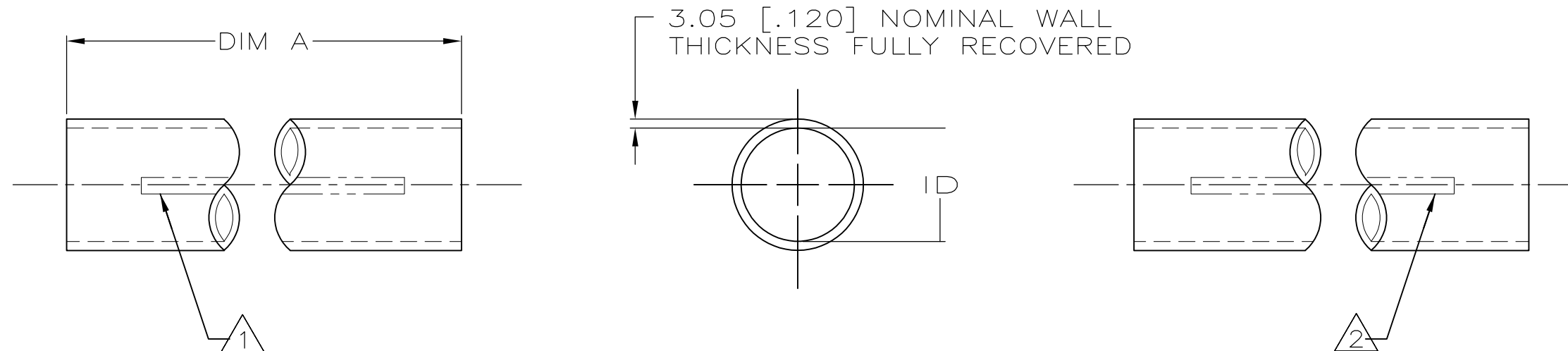

27.94 [1.100] MINIMUM EXPANDED
 9.53 [.375] MAXIMUM RECOVERED

- ① PRODUCT MARKED WITH AMP, AND DATE CODE WITH 6.35 [.25] HIGH CHARACTERS USING WHITE INK LOCATED ALONG THIS SURFACE. REPEAT EVERY 203.2 [8.0] INCHES.
- ② PRODUCT MARKED 1.100 - .375/ 28mm - 9.5mm WITH 6.35 [.25] HIGH CHARACTERS USING WHITE INK LOCATED ALONG THIS SURFACE. REPEATED EVERY 203.2 [8.0] INCHES.
- ③ WEIGHT PER LINEAR FOOT: 54.4 GRAMS/ .12 POUNDS.
- ④ OBSOLETE PARTS: OBSOLETE CIS STREAMLINING PER D.RENAUD/D.SINISI

④ OBSOLETE	304.8 ±4.8 [12.00 ±.19]	53702-6
	7696.20 - 7620.00 [303 - 300]	53702-2
	1244.6 - 1219.2 [49.00 - 48.00]	53702-1
	DIM A	PART NO

DO NOT SCALE PRINT. UNLESS SPECIFIED DIMENSIONS IN mm [INCHES] TOLERANCES ON: 2 PLC DEC ± - 3 PLC DEC ± - ANGLES ± -	DR 1-21-94 W CHANDLER	AMP Incorporated Harrisburg, PA 17105-3608 NAME AMPSULATION HWP31, HST WITHOUT SEALANT 1.100 INCHES DIAMETER		
	CHK -			
	APPD -			
	APPD -			
MATERIAL BLACK POLYOLEFIN	PRODUCT SPEC -	SIZE B	CAGE CODE 00779	DRAWING NO C-53702
FINISH -	APPLICATION SPEC -	SCALE -	SHEET 1 OF 1	
	WEIGHT ③			

THIS DRAWING IS A CONTROLLED DOCUMENT FOR AMP INCORPORATED. IT IS SUBJECT TO CHANGE AND THE CONTROLLING ENGINEERING ORGANIZATION SHOULD BE CONTACTED FOR THE LATEST REVISION.