

LOC		DIST		REVISIONS			
GP	00	REV	DATE	BY	CHK	APP	REV
B		REVISED PER ECO-08-007327	09APR08	BM	WM		

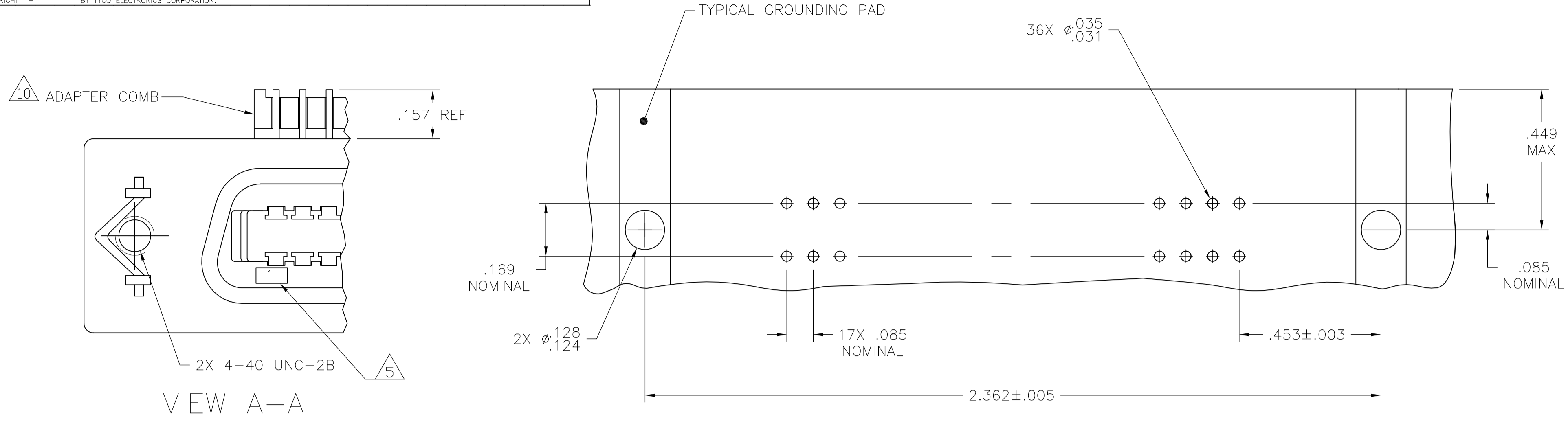

SUGGESTED PRINTED CIRCUIT BOARD MOUNTING DIMENSIONS



SUGGESTED REAR PANEL MOUNTING CUTOUT DIMENSIONS

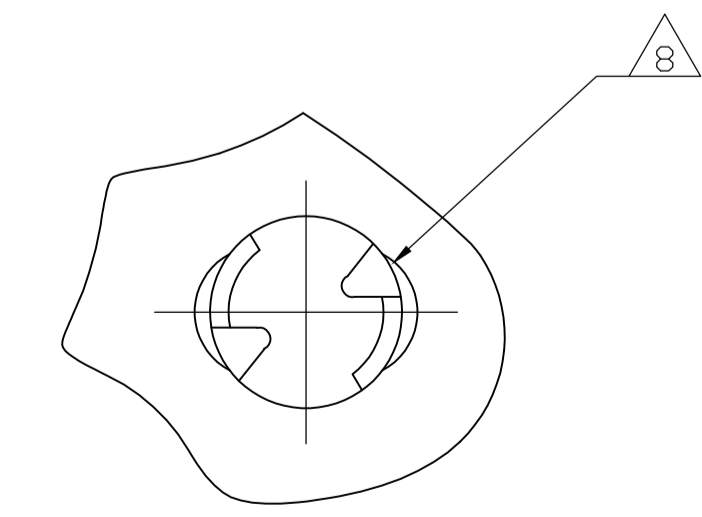
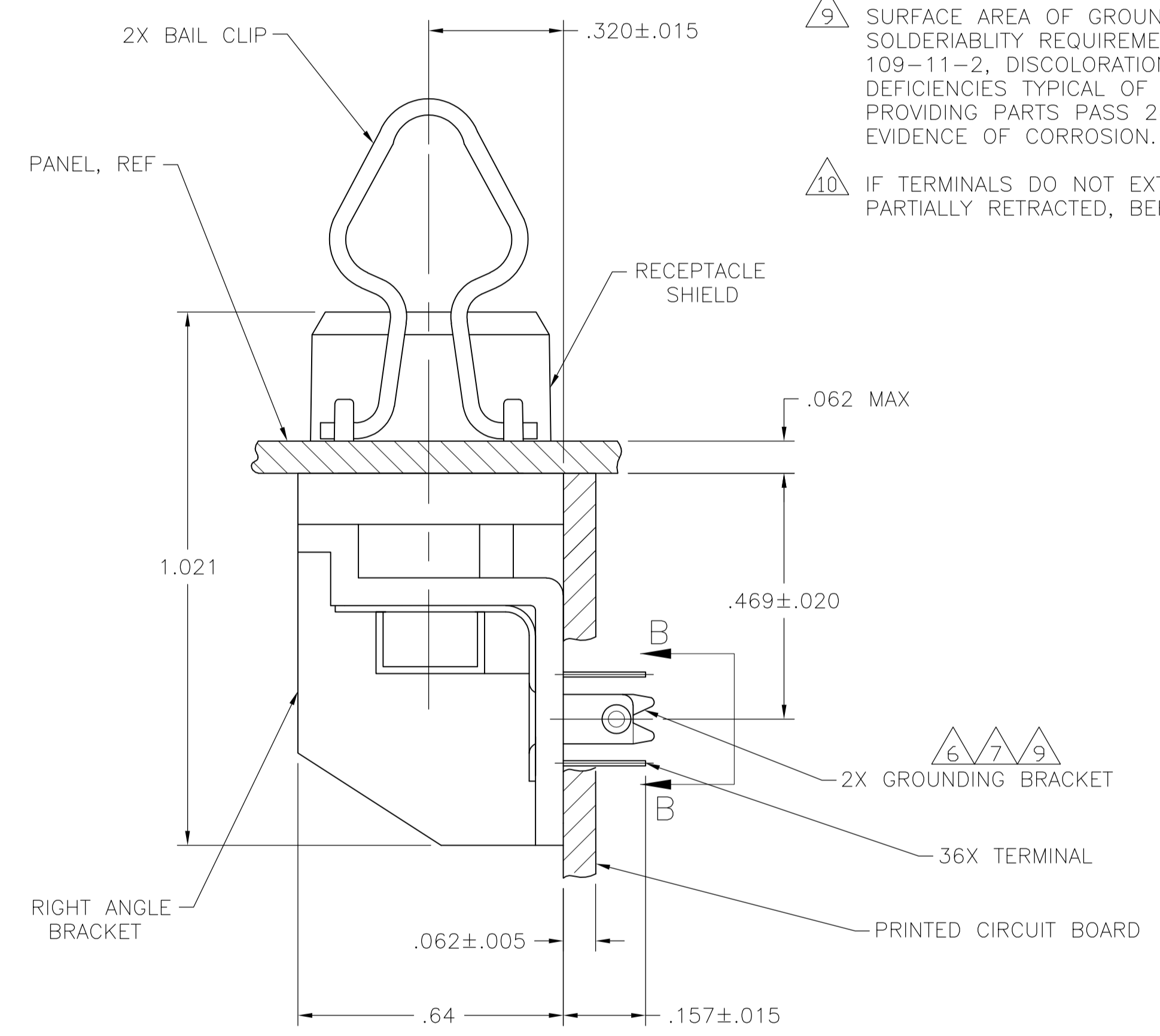

DETAIL B-B

- 1 MATERIAL:
HOUSING, RIGHT ANGLE BRACKET, ADAPTER COMB & TERMINAL SUPPORT PLATE - THERMOPLASTIC, BLACK.
RECEPTACLE SHIELD - BRIGHT NICKEL OVER COPPER PLATED DIE CASTING.
TERMINALS - HIGH STRENGTH COPPER ALLOY PLATED WITH EITHER .000030 MIN GOLD PLATE OR GOLD FLASH OVER PALLADIUM NICKEL PLATE, .000030 MIN TOTAL ON MATING SURFACE. .000120 MIN TIN PLATE ON TAILS. ALL OVER .000050 MIN NICKEL UNDERPLATE OVER ENTIRE TERMINAL.
GROUND BRACKET - TIN PLATED CARBON STEEL.
2. THE CONTACT SURFACES OF THE TERMINALS ARE COATED WITH LUBRICANT.
3. CENTER TO CENTER SPACING OF TERMINALS IS 0.85 NOMINAL.
- 4 ALL DIMENSIONS ARE MAXIMUM UNLESS OTHERWISE SPECIFIED.
- 5 TERMINAL 1 IS LOCATED IN THIS ROW FOR STANDARD ORIENTATION, SEE DETAIL A.
- 6 GROUNDING BRACKET RETAINS CONNECTOR IN .062 THICK PC BOARD WITHOUT ADDITIONAL HARDWARE.
- 7 GROUNDING BRACKET LOCATES CONNECTOR FLUSH WITH TOP OF PC BOARD AND SPRING LOCKS BENEATH.
- 8 CYLINDRICAL SHAPE OFFERS 180° OF SOLDERING SURFACE.
- 9 SURFACE AREA OF GROUNDING BRACKET BELOW PC BOARD SHALL PASS SOLDERABILITY REQUIREMENTS IN ACCORDANCE WITH AMP SPECIFICATION 109-11-2, DISCOLORATION, SCRATHES, SPOTS AND OTHER COSMETIC DEFICIENCIES TYPICAL OF BARREL PLATING PROCESS ARE ACCEPTABLE PROVIDING PARTS PASS 24 HOUR EXPOSURE AT 95% RH AT 40°C, WITHOUT EVIDENCE OF CORROSION.
- 10 IF TERMINALS DO NOT EXTEND BELOW COMB, THEN COMB SHALL BE PARTIALLY RETRACTED, BEFORE INSERTING CONNECTOR INTO THE PC BOARD.

THIS DRAWING IS A CONTROLLED DOCUMENT.		DIN B	24AUG05	Tyco Electronics Corporation Harrisburg, PA 17105-3608	
DIMENSIONS: INCHES		CMC W	24AUG05	NAME RECEPTACLE ASSEMBLY, SHIELDED, 36 POSITION, RIGHT ANGLE, W/ BOARD LOCK & BAIL LOCK, FLUSH MOUNTING CHAMP	
TOLERANCES UNLESS OTHERWISE SPECIFIED:		APVD W	24AUG05	RESTRICTED TO	
0 PLC	±	PRODUCT SPEC			
1 PLC	±	APPLICATION SPEC			
2 PLC	±				
3 PLC	±				
4 PLC	±				
ANGLES	±				
MATERIAL	1	SIZE	A1	WEIGHT	
FINISH	1	CAGE CODE	00779	DRAWING NO	5555119
		SCALE	4:1	SHEET	1 OF 1
		CUSTOMER DRAWING		REV	B

5555119-1
PART NUMBER