

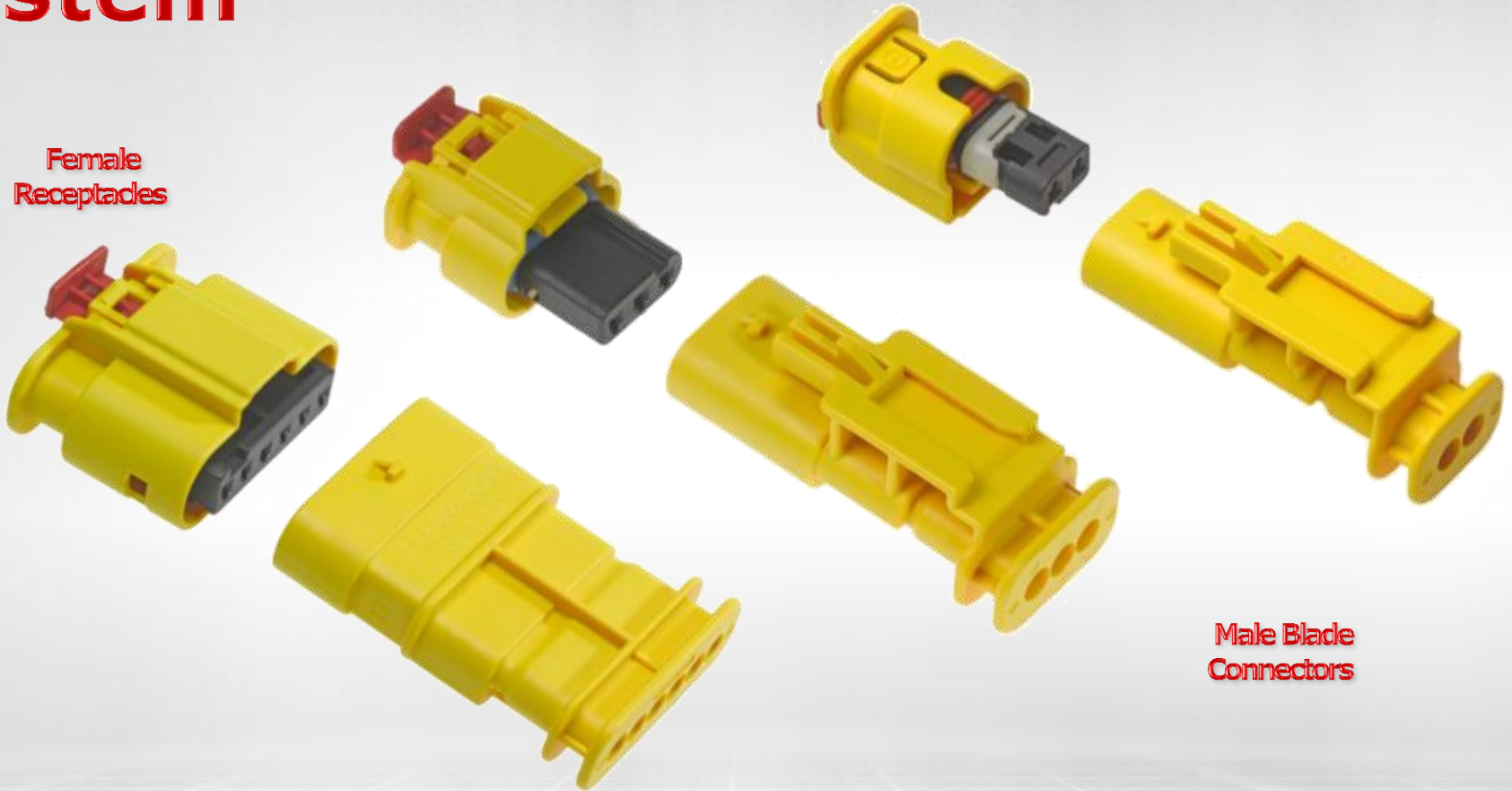

› **MXP120™ Sealed
Connector System**

MXP120™ Sealed Connector System

**Female
Receptacles**



**Male Blade
Connectors**

**MXP120™ Sealed Connector System for Safety Applications
1-by-2, 1-by-3 and 1-by-6 Circuits**

molex®



UNIQUE SELLING PROPOSITION

The high-performance, compact MXP120™ Sealed Connection System handles harsh environments and can replace common 1.50mm systems in space-constrained in-line harness applications

molex®



WHAT PROBLEM OR ISSUE IS THIS PRODUCT SOLVING?

Automotive and commercial vehicle makers face tighter space requirements for safety-restraint and harness applications. Offering high-power in a compact package size the MXP120™ Sealed System is a USCAR specified solution that can replace existing 1.50mm terminal systems in space-constrained harness applications

molex

Product Development

- **Connectors with yellow outer-housings have been qualified as per T3-V2-S2 (Temperature up to 125° C / on-engine vibration up to 200m/s²) performance level**
- **Targeted for in-vehicle safety system applications**

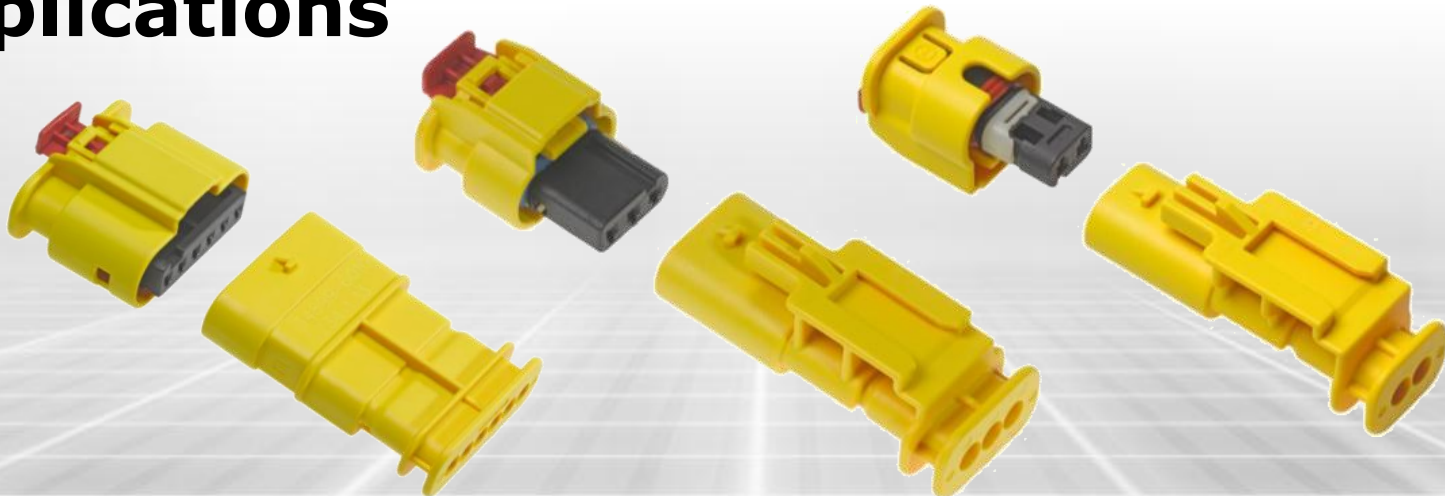

Markets and Applications

- **Sealed applications in automotive & commercial vehicles:**
- **Yellow Housings: Safety systems (125° C on-engine vibration):**
 - Supplemental Inflatable Restraints (SIR)
 - Safety Restraint Systems (SRS)
 - Seat-belt pretensioners
 - Airbags - steering wheel / side / curtain



In-vehicle safety systems

Key Features

Female Receptacles

Integral Locking-Latch and Bridge Protection

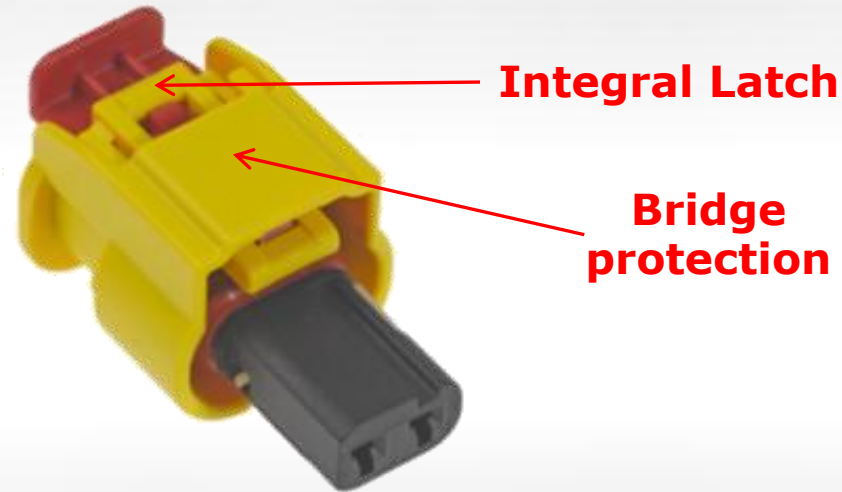

- Receptacle features integral locking-latch that provides excellent mating performance and an audible click
- This is a **competitive advantage versus existing products on the market**
- A bridge over the latch completely protects it from potential damage or permanent stress during packaging and storage and guarantees optimum mating performance in all conditions

Key Features

Female Receptacles

Ergonomic and Robust CPA

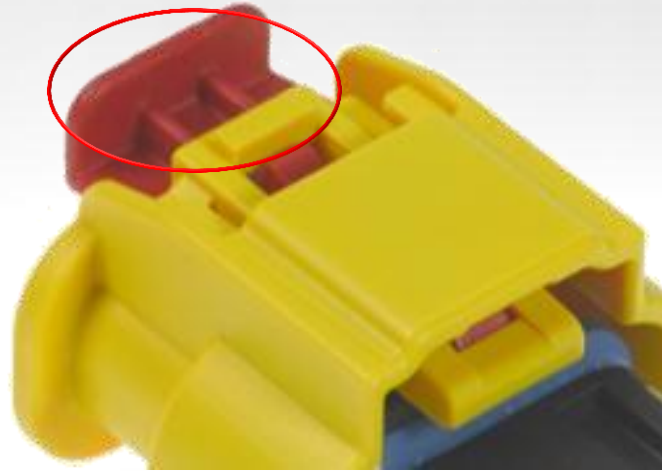

- Enlarged CPA vs. competitor versions for superior ergonomics
- Robust CPA design limits the risks of breakage (during handling / wires snagging) or pre-seating prior to connector mating
- CPA actuation is a one-step process to minimise assembly operation
- After connector mating the CPA and integral latch combine to stabilise the connector interface without impact to mating force

Key Features

Female Receptacles

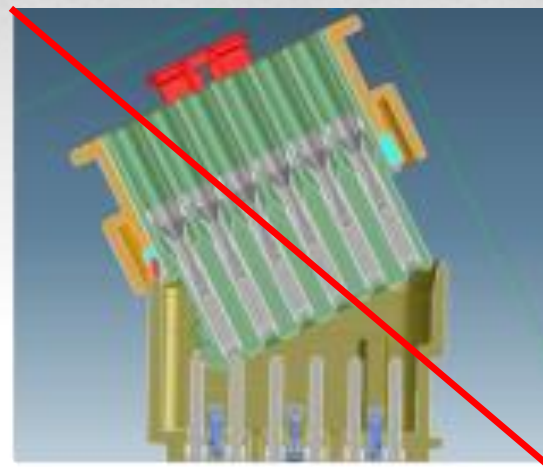
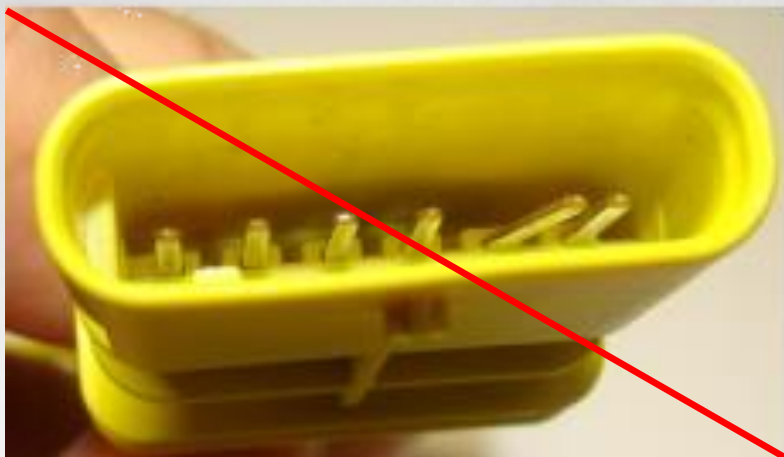

Scoop-proof design prevents damage to pins during mating



Short shroud

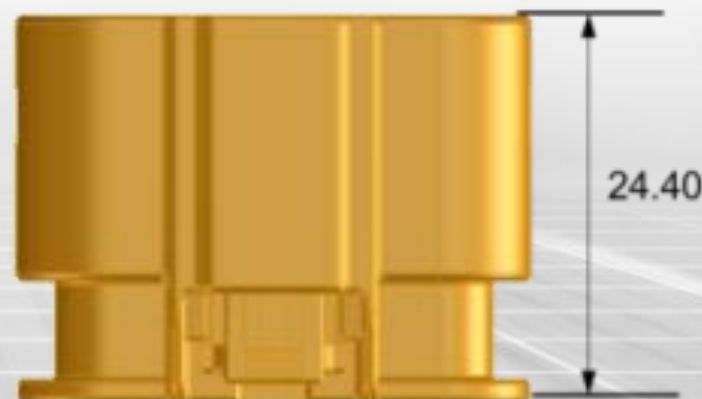

Long shroud

Key Features

Female Receptacles



**Short shrouds
(2 & 3 Circuits)**



**Long shrouds
(4 & 6 Circuits)**

- › Our research showed that with some specific coding options, short shroud versions from competitors available on the market today are not scoop-proof
- › Long shrouds for 1-by-4 and 1-by-6 circuit versions to prevent terminal scooping

Key Features

Independent Secondary Locking (ISL) on female receptacle side:



Receptacle connectors utilise a pre-assembled, side-loaded Independent Secondary Lock (ISL) :

- Improves terminal servicing
- Checks correct terminal position and reinforces primary terminal retention

Key Features

Primary Lock Reinforcement (PLR) on male blade side:

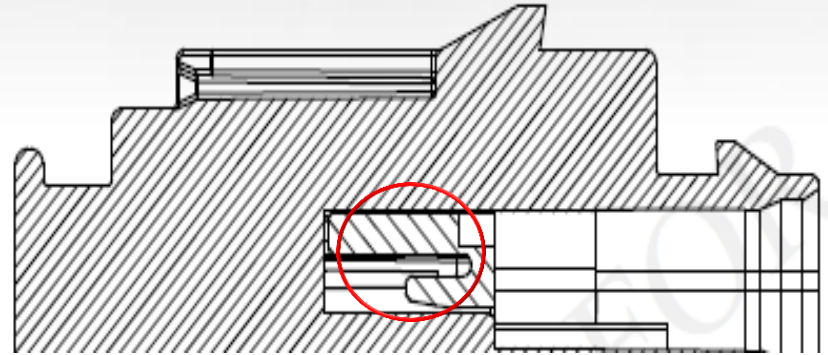
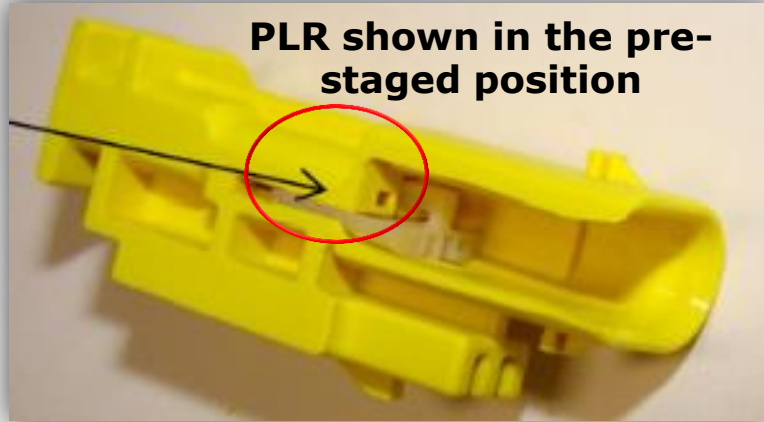

- Male blade connectors utilise a pre-assembled front-loaded PLR (also known as TPA)
 - Helps to minimise the number of components, making this connector very price competitive
 - Improves terminal servicing
 - Checks finger position of terminal latch and reinforces terminal retention

Additional Key Features

- › **Handles up to 13.0A**
- › **Withstands high-pressure spray environments**
- › **Reduced package size when compared to existing 1.50mm connection systems**
- › **Compatible with AK and USCAR interfaces**

Ordering Information



Circuits	Polarization	Color Coding	Receptacle Order No.	Mating Male Connector†	
				7.00mm Clip-Slot	11.00mm Clip-Slot
2	A	Black	34900-2001	34899-2010	-
	B	Light Grey	34900-2002	34899-2011	-
3	A	Black	34900-3001	34899-3010	34899-3030
	B	Light Grey	34900-3002	34899-3011	34899-3031
6	A	Black	34900-6010	34899-6010	34899-6040
	B	Light Grey	34900-6011	34899-6011	34899-6041

† Custom clip-slots available upon request to Product Manager; volume depending

Use With

Terminals:

Manufacturer	Gender	Plating	Terminal Type	Terminal Part No.	Grip Size: Metric (mm ²)	OEM Ratchet Hand Crimper Part No.
Tyco	Female	Silver (Ag)	MCON 1.2 LL SWS	1452665-3	0.35mm ²	x-1528161-x
				1452668-3	0.50mm ²	x-1528162-x
					0.75mm ²	
Kostal			MLK 1.2 LL SWS	1452671-3	1.00mm ²	x-1528163-x
				32124734110	0.35mm ²	80 41 15 14
				32124734120	0.50mm ²	80 41 15 15
Tyco	Male	MCON 1.2 CB SWS	32124734130	0.75mm ²	80 41 15 14	
				1.00mm ²		
			2141114-3	0.35mm ²	-	
2141116-3	0.50mm ²					
	2177610-3	1.00mm ²				

Single Wire Seals:

Manufacturer	Gender	Order No.	Insulation Diameter FLR (mm)	Colour
Tyco	SWS	963142-2	0.9-1.9	Grey
		967067-1	1.9-2.4	Green
	Seal Plug	963143-1	-	White

Associated Sell

> Squib connectors and cable harnesses

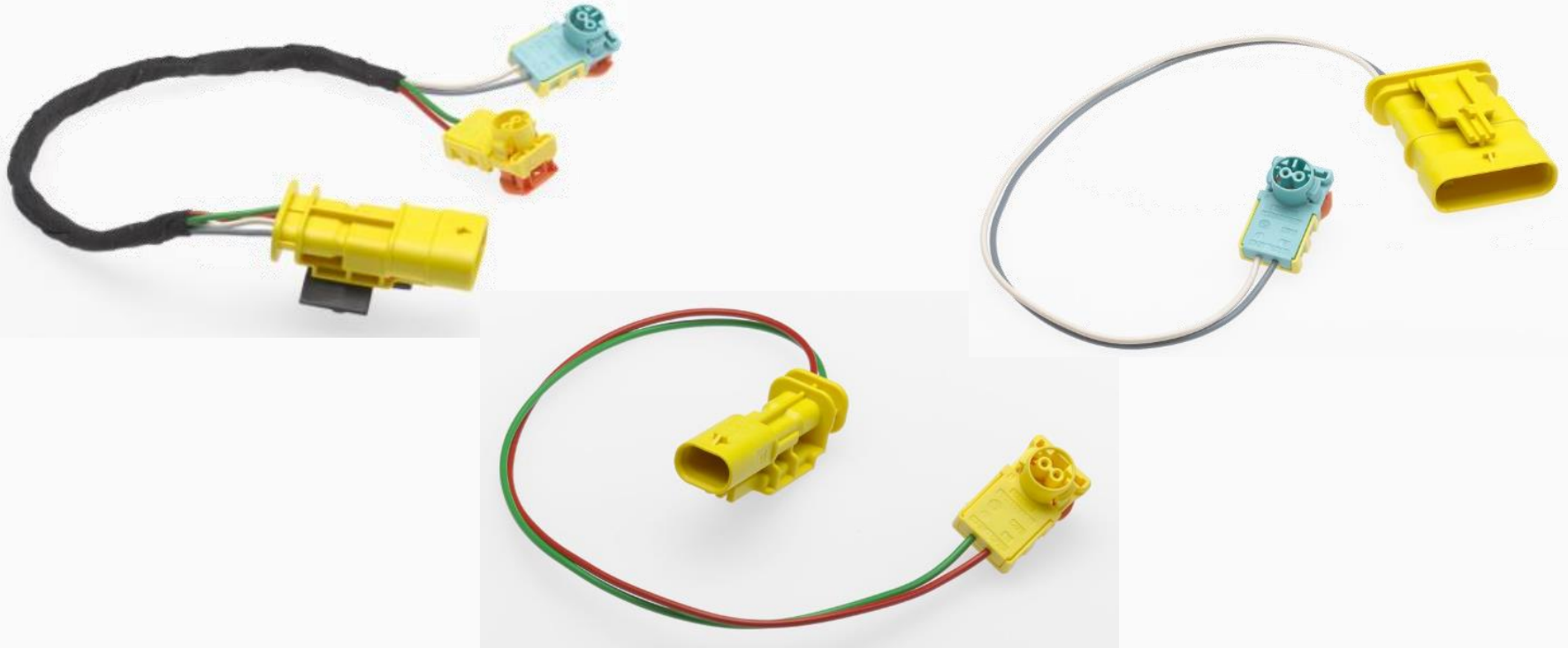

**Molex Cable Harnesses featuring
Squib and MXP120 Connectors**

Associated Sell

> Automotive and Commercial Vehicle Connectors



Learn More.....

➤ Datasheet:

molex

The high-performance, compact MXP120™ Sealed Connector System handles harsh environments and can replace common 1.50mm systems in space-constrained in-line harness applications

Automotive and commercial vehicle makers face tighter space requirements for safety-restraint and harness applications. The MXP120™ Sealed Connector System provides a high-power solution in a compact package size that meets USCAR specifications and can replace existing 1.50mm systems in space constrained harness applications. The use of 1.20mm terminals minimises the connector interface and connector package size versus larger 1.50mm terminals while offering more current carrying capacity and robustness in assembly than is possible with the use of 0.64mm terminal systems.

Connectors with yellow outer-housings have been qualified as per T3-V2-S2 (Temperature up to 125°C / on-engine vibration up to 200m/s²) performance level and are targeted for in-vehicle safety system applications.

Features and Benefits

4.00mm pitch connection system based on 1.20mm terminals	Meets medium-power application requirements up to 13.0A Suitable for most sealed harnessing applications
Single wire seal (SWS) connection system with robust perimeter seal	Withstands high-pressure spray environments
Reduced package size when compared to existing 1.50mm connection systems	Offers significant space-savings for confined design parameters
Accommodates wire gauges up to 1.00mm ²	Limits connector pitch to 4.00mm with SWS
Compatible with AK and USCAR interfaces; designed using worldwide AK cavity definition	Confirms global acceptance and marketability
Female receptacles feature long shrouds for 1 by 4 circuit and above (short shrouds for below 4-circuit)	Ensures all circuit sizes and keying options are scoop proof
Female receptacles with Independent Secondary Locking (ISL) Male blade connectors with Primary Lock Reinforcement (PLR)	Ensures efficient terminal positioning and detection of partial installation of terminals
Female receptacles feature integral locking-latch with bridge protection and audible click	Secure mating performance Avoids damage to the latch during packaging and transit

MXP120™ Sealed Connector System

34900 Single-Row Receptacles

34899 Single-Row Blade Connectors



1 by 2-Circuit MXP120™ Sealed Connector System for Safety Applications



1 by 3-Circuit MXP120™ Sealed Connector System for Safety Applications



1 by 6-Circuit MXP120™ Sealed Connector System for Safety Applications

www.molex.com/link/120sealedconnections.html

molex

Family Development Overview

★ 1-by-2, 1-by-3 and 1-by-6 circuit systems in yellow housing now fully released

Contact Molex for PPAP release schedule of 4- and 6-circuit yellow, and 2-, 3-, 4- and 6-circuit black housings



Yellow Housings:
Safety System Applications

T3-V2-S2 performance (Per GMW3191 specifications)

Black Housings:

Body Electronics and Powertrain Applications

T3V1S2 performance for BE / T4V4S3 performance for PT
(Per GMW3191 specifications)

molex[®]

Ongoing Product Development

- **Connectors with black outer-housings for use in space-constrained powertrain applications will follow**
- **These connectors are designed and being validated as per T4-V4-S3 specifications (per GMW3191) for high-performance (temperatures up to 155° C / vibration up to 300 m/s²)**



molex[®]

Future Target Markets and Applications



► Black Housings:

► Body electronics connections in wet areas (T3-V2-S2 - 125° C on-engine vibration):

- Exterior lighting
- Turn signals (indicators)
- Door-lock mechanisms



Exterior lighting, turn signals and door-lock mechanisms

► Powertrain (T4-V4-S3 - 155° C high-vibration for severe applications, high-pressure jets)

- Fuel injection
- Emission controls
- Ignition coil



Fuel injector



Ignition coil

The image features the Molex logo and tagline centered on a background of a white grid that recedes into the distance. The grid lines are thin and light gray, creating a sense of depth and perspective. The logo and text are in a clean, sans-serif font. The word 'molex' is in red, while the tagline is in black. A small red chevron symbol is positioned between 'company' and 'a world of innovation'.

molex[®]

one company > a world of innovation