

LOC		DIST		P		F		ZONE		LTR		REVISIONS		DATE	APPD	
DF	DO												REV PER 063D-0583-02	CT	1-03	DM

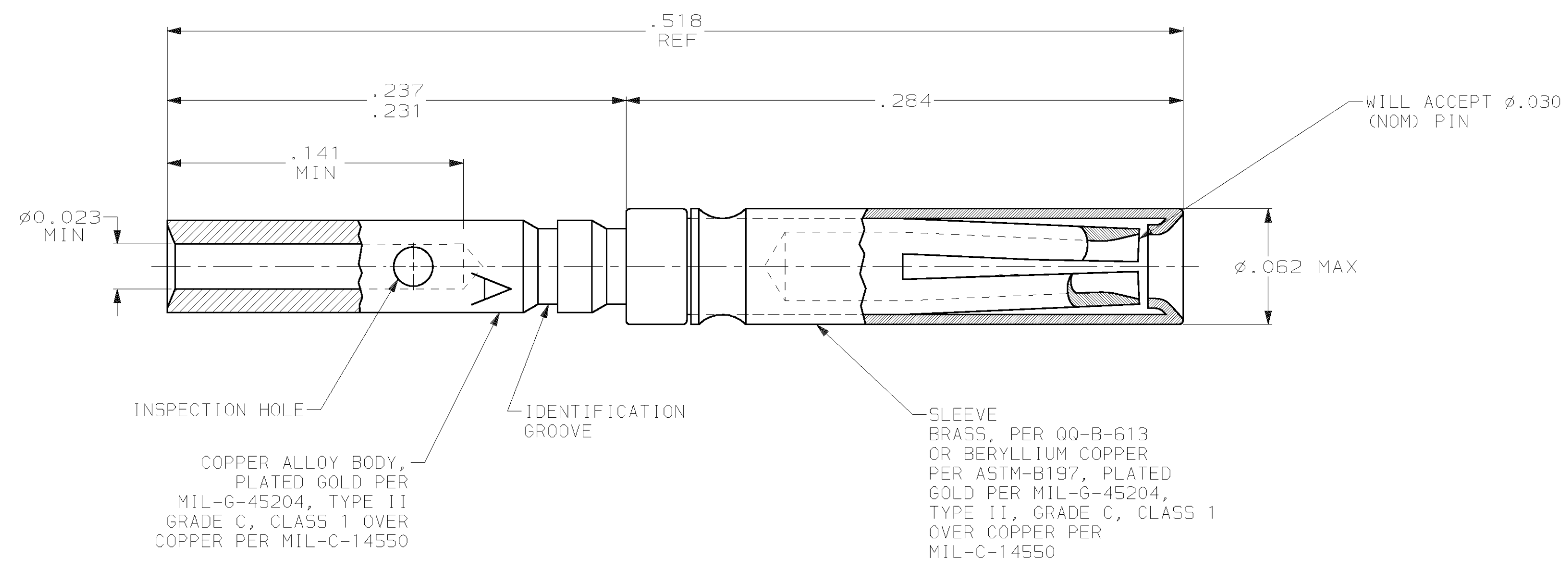

PRESS FIT HOOD CONFIGURATION

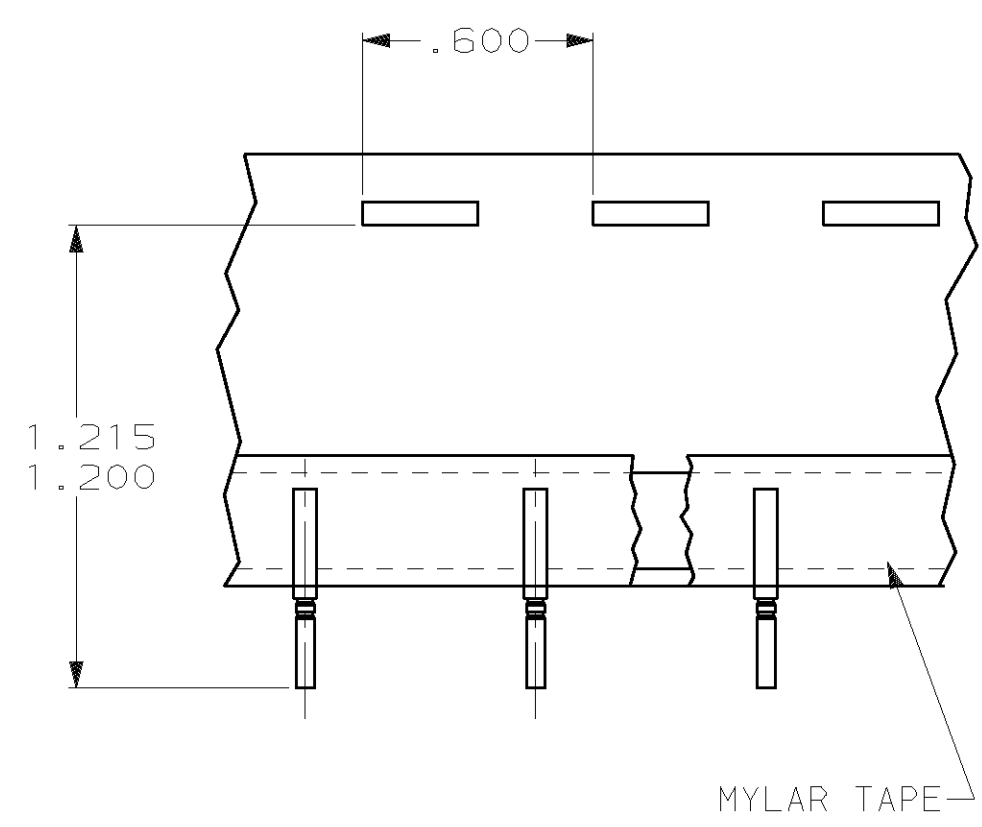

TAPE MOUNTED
-2 ONLY

1. WIRE BARREL WILL ACCEPT #26 - 28 AWG WIRE.
2. CRIMPING TOOL - USE HANDTOOL M22520/2-01 (AMP P/N 601996-1) WITH POSITIONER M22520/2-06 (AMP P/N 601966-4) SEE AMP INSTRUCTION SHEET, IS7516, FOR CRIMPING INSTRUCTIONS.
3. CONTACT CONFORMS TO MIL-C-24308/57-354, EXCEPT NO COLOR CODE AND INSIDE DIAMETER ON CRIMP BARREL IS SMALLER TO ACCEPT #26 - 28 AWG WIRE.
4. INSERTION/EXTRACTION TOOL AMP P/N 91067-1.
5. USE AMP - TAPEMATIC STRIPPER/CRIMPER MACHINE NUMBER 299406-7 WITH FUNNEL NUMBER 125905-2.
6. SLEEVE MAY BE CRIMPED OR DIMPLED ONTO CONTACT BODY.

AS SHOWN EXCEPT ON TAPE		206496-2	
AS SHOWN		206496-1	
DESCRIPTION		PART NO	
DO NOT SCALE PRINT. UNLESS SPECIFIED DIMENSIONS IN mm [INCHES] TOLERANCES ON : 2 PLC DEC ± - 3 PLC DEC ± .005 ANGLES ± -		DR 06-03-94 T. THOMPSON	
MATERIAL SEE CALLOUT		CHK - F. KINSEY APPD - F. KINSEY PRODUCT SPEC -	
FINISH -		APPD - F. KINSEY APPLICATION SPEC -	
WEIGHT .103 GRAMS		SIZE D	CAGE CODE 00779
		DRAWING NO C-206496	SCALE 20:1
		SHEET 1 OF 1	

THIS DRAWING IS A CONTROLLED DOCUMENT FOR AMP INCORPORATED. IT IS SUBJECT TO CHANGE AND THE CONTROLLING ENGINEERING ORGANIZATION SHOULD BE CONTACTED FOR THE LATEST REVISION.

AMP AMP Incorporated
Harrisburg, PA 17105-3508

CONTACT ASSEMBLY,
SOCKET, SIZE 22D