

THIS DRAWING IS UNPUBLISHED. RELEASED FOR PUBLICATION  
 © COPYRIGHT BY TYCO ELECTRONICS CORPORATION. ALL RIGHTS RESERVED.

| LOC | DIST | REVISIONS   |                           |         |        |
|-----|------|-------------|---------------------------|---------|--------|
| P   | LTR  | DESCRIPTION | DATE                      | DWN     | APVD   |
| CE  | 16   | C           | REVISED PER ECR-08-003606 | 04MAR08 | JWD JD |

- 1. SEE TABLE FOR MAXIMUM CONNECTOR INSERTION LOSS AT 1300nm
- 2. PRODUCT AND PROCESSING MUST MEET REQUIREMENTS OF TYCO ELECTRONICS STANDARD 230-702

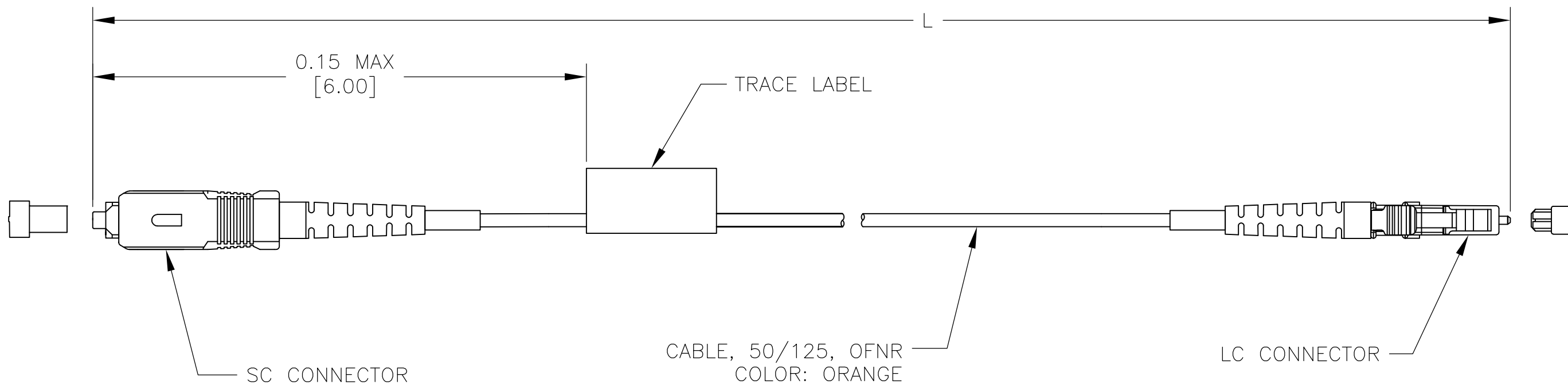

| MAX IL (dB) SC | MAX IL (dB) LC | L METERS [INCHES]      | PART NUMBER |
|----------------|----------------|------------------------|-------------|
| 0.52           | 0.22           | 15.00±0.15 [591.0±6.0] | 1-6374612-5 |
| 0.52           | 0.22           | 10.00±0.15 [393.7±6.0] | 1-6374612-0 |
| 0.51           | 0.21           | 5.00±0.08 [196.9±3.0]  | 6374612-5   |
| 0.51           | 0.21           | 4.00±0.08 [157.5±3.0]  | 6374612-4   |
| 0.50           | 0.20           | 3.00±0.05 [118.1±2.0]  | 6374612-3   |
| 0.50           | 0.20           | 2.00±0.05 [78.7±2.0]   | 6374612-2   |
| 0.50           | 0.20           | 1.00±0.05 [39.4±2.0]   | 6374612-1   |

|  |     |                               |   |                    |     |       |     |       |     |       |     |        |     |                  |  |
|--|-----|-------------------------------|---|--------------------|-----|-------|-----|-------|-----|-------|-----|--------|-----|------------------|--|
| THIS DRAWING IS A CONTROLLED DOCUMENT.   |     | DWN<br>C.S.VASU<br>02 SEP 05  | Tyco Electronics Corporation<br>Harrisburg Pa, 17105-3608                         |                    |     |       |     |       |     |       |     |        |     |                  |  |
| DIMENSIONS:<br>METERS [INCHES]   |     | CHK<br>J.DUNCAN<br>02 SEP 05  | NAME<br>CABLE ASSY, FIBER OPTIC, 50/125um,<br>2.0mm OFNR, AMP SC (NG) TO LC, RoHS |                    |     |       |     |       |     |       |     |        |     |                  |  |
| TOLERANCES UNLESS OTHERWISE SPECIFIED:   |     | APVD<br>J.DUNCAN<br>02 SEP 05 | PRODUCT SPEC  |                    |     |       |     |       |     |       |     |        |     |                  |  |
| <table border="0"> <tr><td>0 PLC</td><td>± -</td></tr> <tr><td>1 PLC</td><td>± -</td></tr> <tr><td>2 PLC</td><td>± -</td></tr> <tr><td>3 PLC</td><td>± -</td></tr> <tr><td>4 PLC</td><td>± -</td></tr> <tr><td>ANGLES</td><td>± -</td></tr> </table> |     | 0 PLC                         | ± -   | 1 PLC              | ± - | 2 PLC | ± - | 3 PLC | ± - | 4 PLC | ± - | ANGLES | ± - | APPLICATION SPEC |  |
| 0 PLC  | ± - |                               |   |                    |     |       |     |       |     |       |     |        |     |                  |  |
| 1 PLC  | ± - |                               |   |                    |     |       |     |       |     |       |     |        |     |                  |  |
| 2 PLC  | ± - |                               |   |                    |     |       |     |       |     |       |     |        |     |                  |  |
| 3 PLC  | ± - |                               |   |                    |     |       |     |       |     |       |     |        |     |                  |  |
| 4 PLC  | ± - |                               |   |                    |     |       |     |       |     |       |     |        |     |                  |  |
| ANGLES   | ± - |                               |   |                    |     |       |     |       |     |       |     |        |     |                  |  |
| MATERIAL   |     | WEIGHT                        | SIZE<br>A3  | CAGE CODE<br>00779 |     |       |     |       |     |       |     |        |     |                  |  |
| FINISH   |     | DRAWING NO<br>G-6374612       |   |                    |     |       |     |       |     |       |     |        |     |                  |  |
|  |     | RESTRICTED TO                 |   |                    |     |       |     |       |     |       |     |        |     |                  |  |
| CUSTOMER DRAWING   |     | SCALE<br>NTS                  | SHEET<br>1 OF 1   | REV<br>C           |     |       |     |       |     |       |     |        |     |                  |  |