

THIS DRAWING IS UNPUBLISHED. RELEASED FOR PUBLICATION, 19 .
 © COPYRIGHT 19 BY AMP INCORPORATED. ALL INTERNATIONAL RIGHTS RESERVED.

LOC		DIST		P		F		REVISIONS		DATE	APPD
ZONE	LTR	DESCRIPTION									
G	14					A	REV & REDRAWN PER 0720-0061-93	4-16-93	DA P		

METRIC
 DIMENSIONS LISTED IN mm [INCHES]

AMP WIRE RANGE	UL E13288 Listed
16-14 AWG SOLID OR STRANDED	NOT APPLICABLE
SR LR7189 Certified	MILITARY P/N AND CLASS
NOT APPLICABLE	NOT APPLICABLE

- ① STAMP AMP 16-14 APPROX AS SHOWN
- ② WIRE BARREL COLOR CODED ORANGE TO DENOTE NICKEL MATERIAL

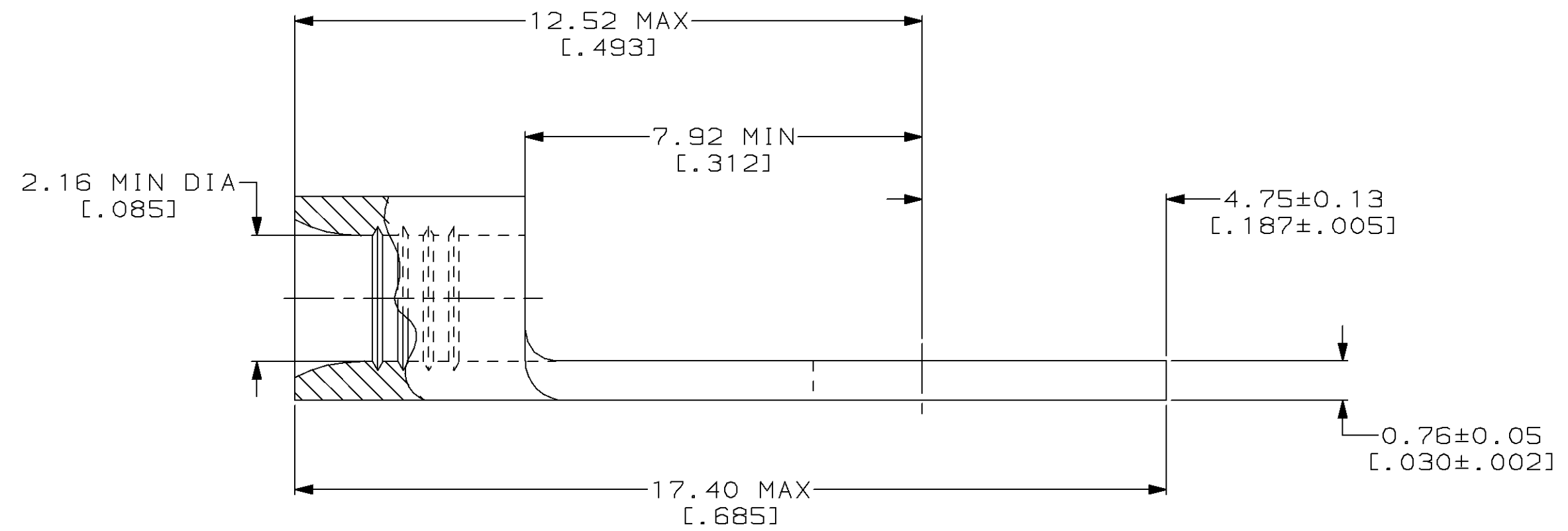
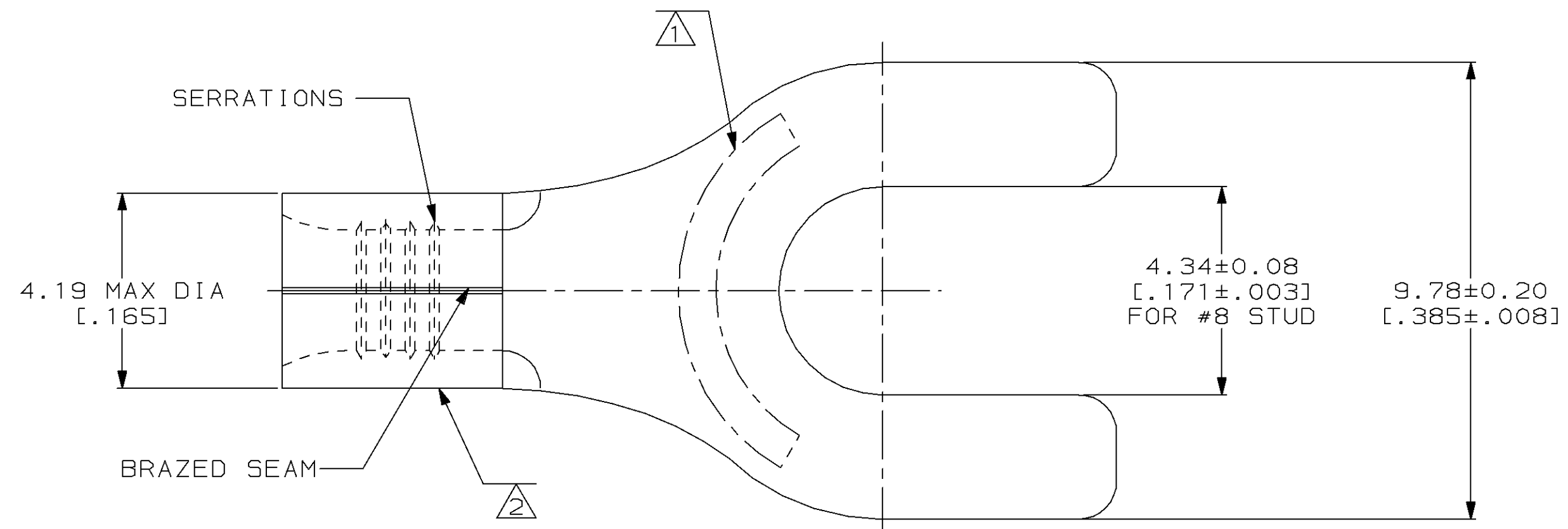

323905
 PART NO

AMP INCORPORATED
CUSTOMER SERVICE SYSTEMS

FOR ADDITIONAL PRODUCT INFORMATION OR COPIES OF DRAWINGS AND TECHNICAL DOCUMENTS	PRODUCT INFORMATION CENTER 1-800-522-6752
FOR APPLICATION TOOLING INFORMATION	TOOLING ASSISTANCE CENTER 1-800-722-1111
FOR ORDER ENTRY	1-800-526-5142

MAX RECOMMENDED OPERATING TEMPERATURE:
 649°C MAX

VOLTAGE RATING:
 NOT APPLICABLE

WIRE CROSS SECTIONAL AREA RANGE:
 1.04-2.62mm² [2,050-5,180] CIR MILS
 SOLID OR STRANDED

THIS DRAWING IS A CONTROLLED DOCUMENT FOR AMP INCORPORATED. IT IS SUBJECT TO CHANGE AND THE CONTROLLING ENGINEERING ORGANIZATION SHOULD BE CONTACTED FOR THE LATEST REVISION.

DO NOT SCALE PRINT. UNLESS SPECIFIED DIMENSIONS IN mm [INCHES]— TOLERANCES ON :	DR 4-16-93 TA BRINKMAN
2 PLC DEC ± -	CHK 4-16-93 DA PATTERSON
3 PLC DEC ± -	APPD 4-16-93 DE MILLER
ANGLES ± -	APPD 4-16-93 JL MECKLEY
MATERIAL NICKEL PER ASTM B-162 ANNEALED	PRODUCT SPEC -
FINISH -	APPLICATION SPEC -
WEIGHT -	

AMP AMP Incorporated Harrisburg, PA 17105-3608		
NAME TERMINAL, SPADE TONGUE, HIGH TEMPERATURE, STRATO-THERM™		
SIZE ③	CAGE CODE 00779	DRAWING NO ③=323905
SCALE 10:1	SHEET 1 OF 1	